

SPLASH BLOCKS

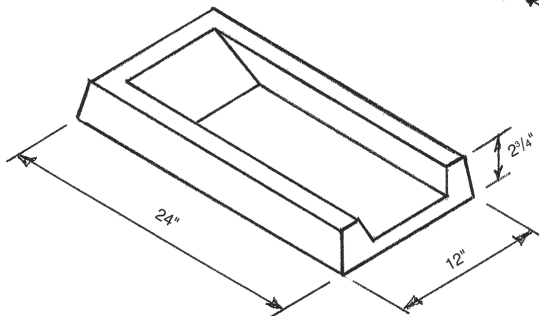

24" SPLASH BLOCK #1

- WEIGHT: 40 LBS.
- PALLET QUANTITY: 48

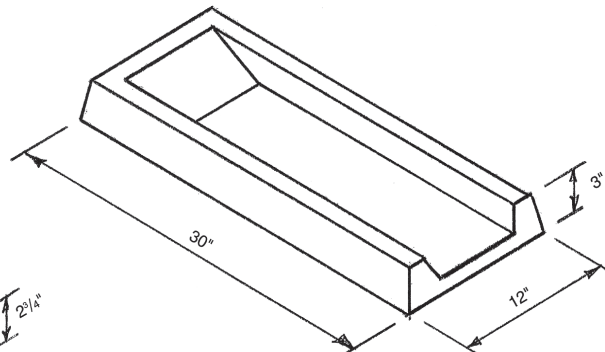

30" SPLASH BLOCK #2

- WEIGHT: 40 LBS.
- PALLET QUANTITY: 24

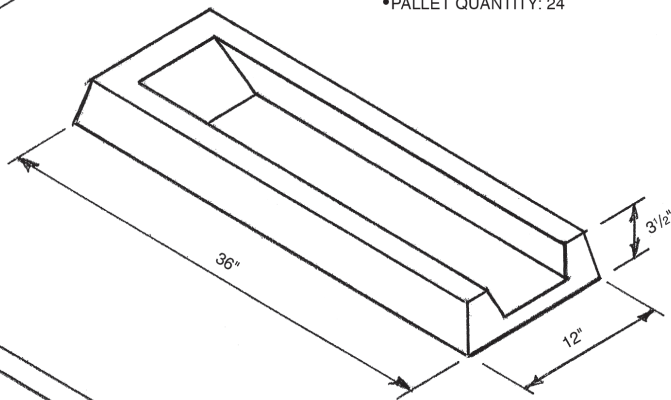

36" SPLASH BLOCK #3

- WEIGHT: 86 LBS.
- PALLET QUANTITY: 24

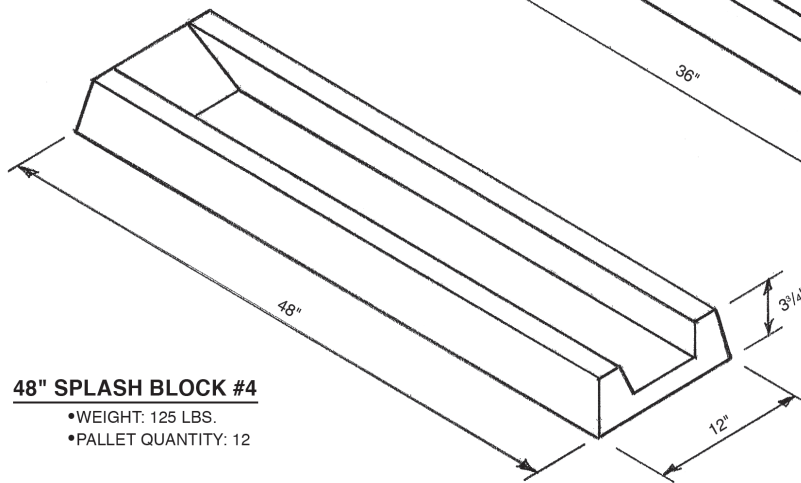

48" SPLASH BLOCK #4

- WEIGHT: 125 LBS.
- PALLET QUANTITY: 12

BASIC USES AND FEATURES

- For use under downspout outlet at ground level or at a roof level.
- Directs water and prevents washout under downspout outlet.
- Meets FHA standards for acceptable lengths.

COMPOSITION & MATERIALS

- Concrete: Air entrained, achieving 5000 PSI compressive strength in 28 days.

AVAILABLE FINISH

- Smooth As-cast Surfaces, natural concrete color.