



**Modular Rain Garden** INSTALLATION MANUAL



# FRENO<sup>TM</sup> Modular Rain Garden

## System Overview

Freno is a pre-cast modular system that allows rapid construction of rain gardens that can serve as bio-retention areas.

- The system can be installed using light equipment. System components require equipment with a lifting capacity of \_\_\_\_\_lbs. Many Compact Excavators and Skid-Steer Loaders are well suited to this task. Typically a two man crew is all that is required to install the system (one machine operator and one laborer).
- Each Freno module has built-in connection inserts that allow easy attachment to lifting equipment using 3/4" common thread bolts.
- The Freno system can be built in a variety configurations using a limited number of modules that are mechanically connected using stainless steel rods.
- No concrete footing is required. The system components are installed on a compacted base material footing.
- Because Freno Components are produced in a controlled factory environment, structural and aesthetic quality control is assured.

1



## System Components

The Freno System consists of five basic module shapes that can be used to construct a variety of configurations of structures.

The modules each have lifting connections placed to assist in connecting the system to lifting equipment to facilitate placement of the modules during construction and for potential attachment of accessories to the finished structure.

The modules are designed to overlap and connect with 1/2" stainless steel pins.

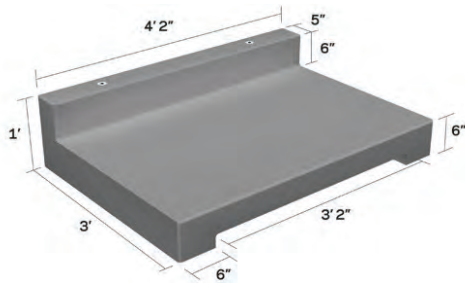

N • MODULE

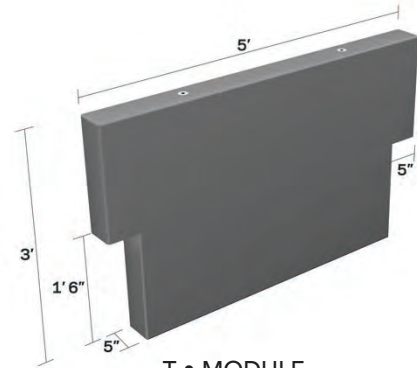

T • MODULE

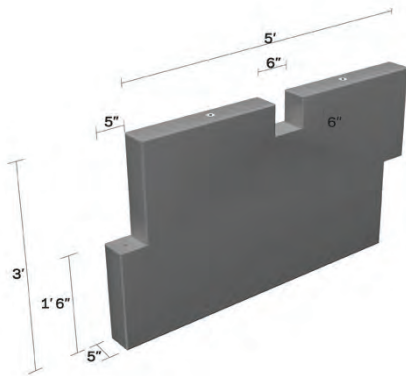

S • MODULE

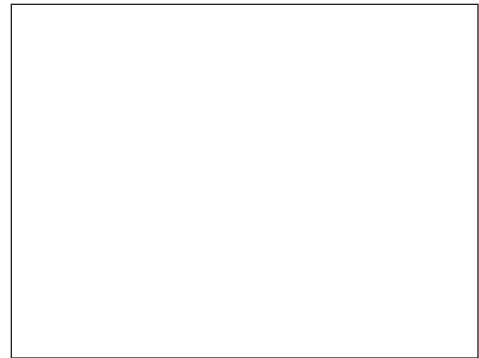

T2 • MODULE

# System Configuration : Endless Options

The Freno System allows great flexibility in the construction of a variety of structure configurations because it is a kit of parts. Here are several examples of possible configurations.

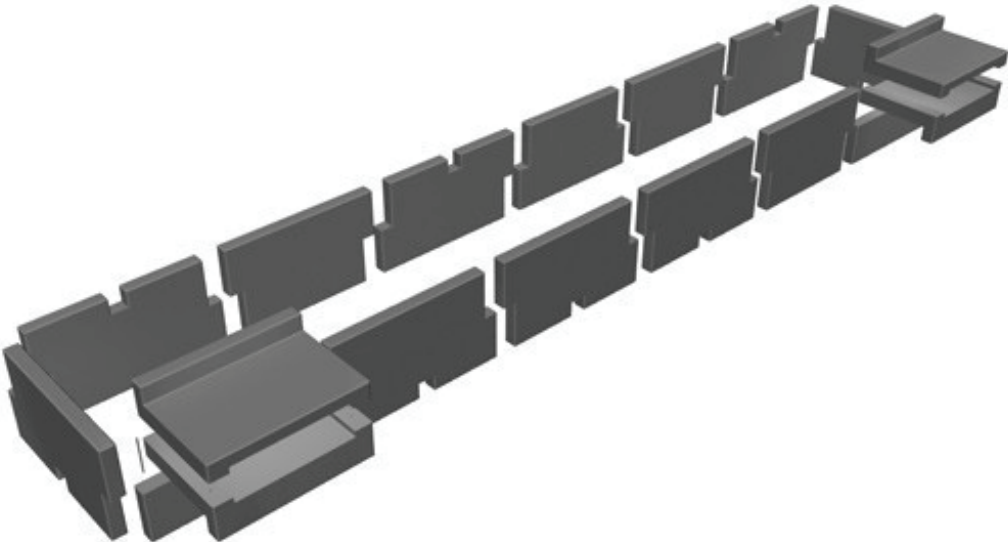

## Pre-Construction Planning

Before beginning construction, planning will help assure a successful installation. Here are several important steps to include in your planning process:

### Implement A Safety Plan

Request marking of underground utilities from your local service prior to excavation. Call 811 or use the state specific information at <http://www.call811.com/state-specific.aspx>.

Place construction barriers and hazard markings to limit access to the site while under construction and divert traffic dangers away from site workers.

### Pre-Construction Site Review

Obtain engineering plans for the project and any required permits.

Note any access restrictions requiring special planning, and any overhead wires or obstructions that may interfere with lifting equipment. Review your equipment requirements in light of site conditions.

Review plans and note any site issues that conflict with project plans for discussion with project designers.

Plan how to stage pallets of Freno Modules and other materials for efficient material handling based on installation configuration and mark the site accordingly prior to material delivery.

## Construction Scheduling Considerations

Schedule installation and fill of the Freno™ System at a time when surrounding surfaces have been stabilized and sedimentation is controlled. It is critical that the bio-retention fill not become contaminated by sedimentation during construction.

A typical Freno™ installation will be completed rapidly (one to two days of construction time per structure is typical, depending on complexity and size), but some care should be taken if construction will be interrupted for any reason, or if the surrounding site soils are not stabilized.

The planting soils should not be delivered to the site before the Freno™ System has been installed and the under-drain system, if any, has been installed.

It may be most efficient to place the plant materials after paving has been completed to avoid repetition of effort since performing the paving work may require access from within the bio-retention area, which could damage the plant materials.

The construction sequence is very straightforward:

| Stage |  | Material   | Typical Equipment Required              |
|-------|--|--|---|
| 1     | Pre-Construction Site Review   | Safety barriers and markers  | None                                    |
| 2     | Site Preparation, Demolition and Excavation (installation of under-drain, if required) | Under-drain system materials (if required). Order base material and Freno Module delivery. | Compact excavator and skid-steer loader |
| 3     | Place and Compact Base Leveling Pad  | Base Material and Freno Modules  | Plate compactor, skid-steer loader      |
| 4     | Place Freno Modules  | Pins, Lifting Clutches   | Compact excavator or skid-steer loader  |
| 5     | Backfilling and Planting   | Crushed stone backfill, Bio-retention fills - planting soils, sands and aggregates, plants | Skid-steer loader                       |

STAGE 1

Site Preparation, Demolition and Excavation

Place safety barriers, markings and signs as required by site safety plan.

Locate all underground utilities before beginning demolition and excavation, and resolve any conflicts with site plans.

Remove existing pavements, plant material or structures from the area to be excavated. Grade site to plan elevations. Stabilize graded area to minimize sedimentation during construction. Place erosion control devices, as required to prevent sedimentation of the system.

Excavate trench to the depths and shape called for in the plans, minimizing compaction of site soils in the trench as much as possible.

[recommendation regarding amount of over excavation and illustration - Rendering of plan view of recommended trench configuration].

If your system will include an under-drain, excavate for under-drain system and install pipe to connect into local stormwater drainage system per specifications. Backfill as specified. Take care not to damage the under-drain during placement of aggregate fills. Sizing and installation for the under-drain pipe system should be specified in the project plans.

Prior to covering the under-drain system, the inspector will need to inspect the under-drain installation, its connections, and any filter fabrics that are used.



Place safety barriers



Site preparation and demolition



Excavation

rendering of excavation

## Place, Compact and Level Base Leveling Pad

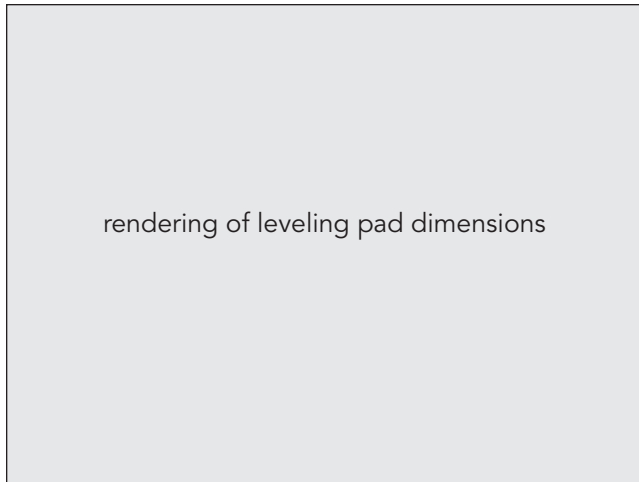

rendering of leveling pad dimensions

The leveling pad is the foundation of the system and placing it correctly is a key to a successful installation.

### [Filter fabric?]

Use a readily compacted base material consisting of granular inorganic soils (some common names for this type of material are "Class #5", "Road Base", etc). The material's maximum particle size should be 3/4" (20mm) and minimum particle size should be such that no more than 10% of the material passes a No. 200 sieve.

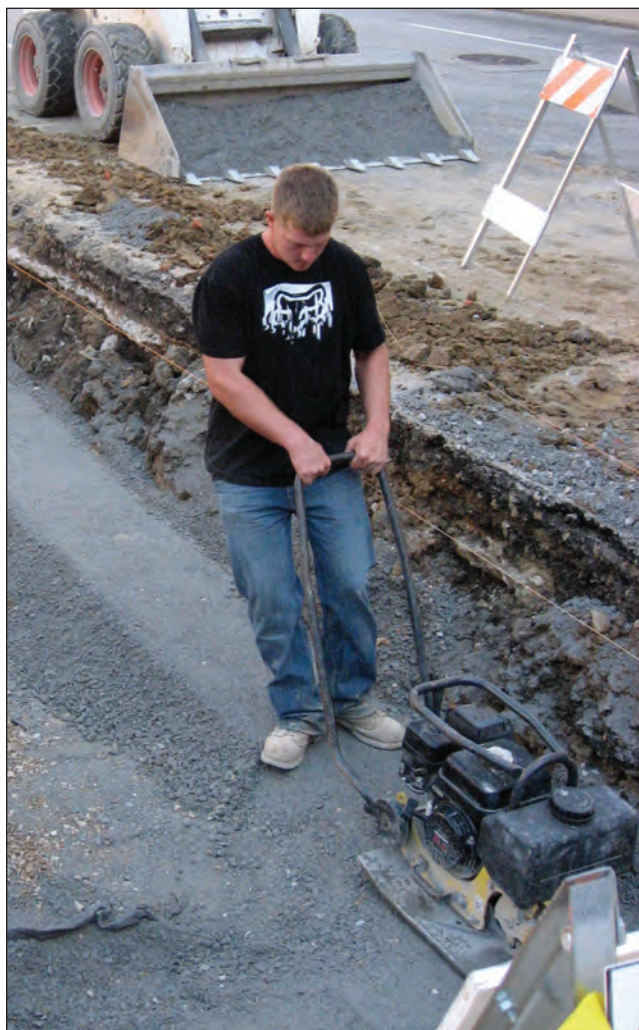

Compacting base material

Place and level a string line (or use a laser leveling device) to assist in installing the base material in a level condition to the elevation specified in the plans.

The leveling pad should be 18" wide and at least 6" thick after compaction (see drawing for typical leveling pad dimensions and placement), which will require placement of greater than 6" base material before compaction.

Compaction should be performed using a mechanical plate compactor. Compaction should be performed to 95% Standard Proctor or 90% Modified Proctor. (soil testing standards to determine % of maximum soil density).

Take care to assure that the compacted base material is level and at plan elevation, as this will speed the process of leveling the Freno Modules when they are installed.



STAGE 3

Install Freno™ Modules

A. Connecting Freno Modules to Lifting Equipment.

Freno Modules are designed to be easily connected to lifting equipment. Stage the pallets of Freno components near where they will be installed. Freno modules can be handled using a Skid-Steer loader or Compact Excavator capable of lifting \_\_\_\_ lbs.

Attach the lifting attachments to the Freno Module using the lifting connections (Figure \_\_\_\_ ) that allow connection to bolts with 3/4" common thread. Connect the lifting connections to a chain (with rated strength of at least \_\_\_\_ ) See Figures \_-\_. Securely attach the chain to the lifting equipment. See Figures \_-\_.

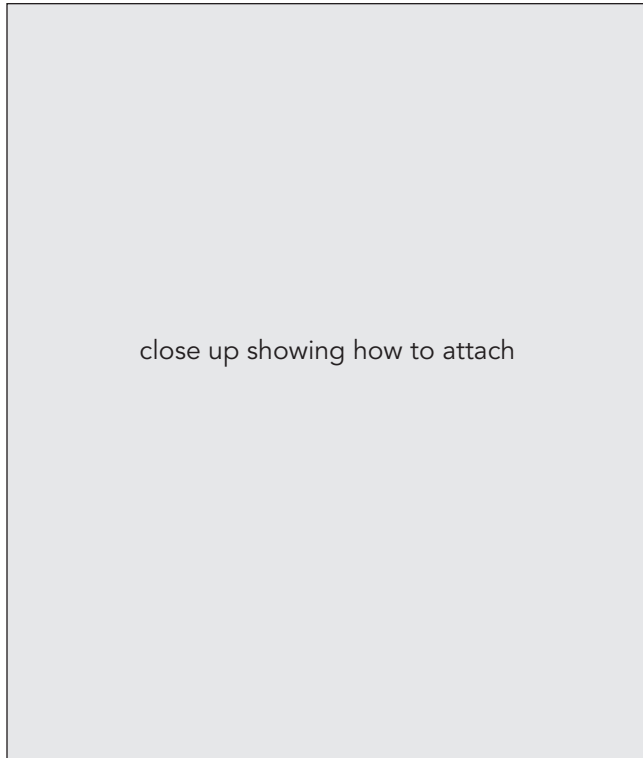

## Install Freno™ Modules

### B. Placing and Leveling Modules.

Using the lifting equipment, place Modules in the sequence shown below in Stage 3.C.

Adjust as necessary to make sure each Module is level, in proper alignment and at plan elevation.

Check plans and assure that modules are oriented correctly with respect to whether intake slots should be placed on top or bottom.

As the modules are installed, shore the system using temporary braces as shown. These braces will no longer be necessary after the structure has been backfilled, but will help assure the modules stay in their proper position during construction.

To assist in leveling the module, a heavy plastic covered mallet may be useful to seat the module and make minor adjustments. Additional base material may be added/removed underneath the panel to address any low/high areas. (Keep the panel attached to the lifting equipment while adjustments are made, and follow safety precautions).

Install and connect adjacent modules in the sequence shown in the next section. Align, level, and check elevations as you go.

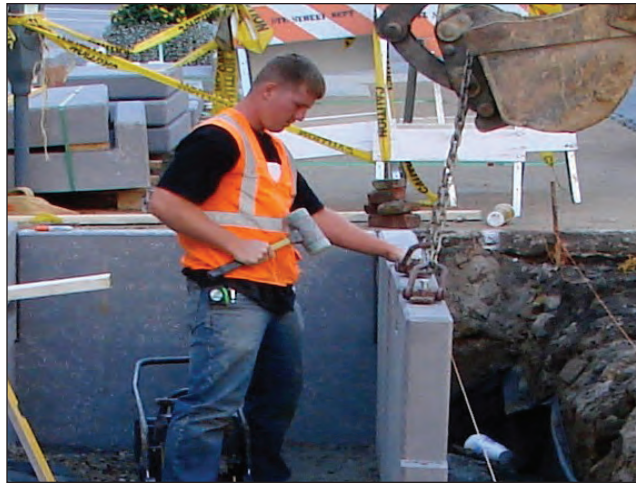

Adjusting a Freno Module



Installing temporary bracing



Confirming that base is level

## Install Freno™ Modules

### C. Sequence of Module Installation.

To start construction, place and level an end module. Then install and connect the adjacent module to build a corner.

#### Construction Notes:

Confirm this module is level, at the right elevation and oriented correctly before moving on.



**Step 1:** Place and level first end Module

Take care to assure that a right angle is established at the corner.

The two T/2 Modules are the foundation for the intake structure, in this case installed adjacent to the corner. Place and level each module and level relative to each other.



**Step 2:** Establish a corner by placing next module. Using a second T2 panel, install the foundation for the intake structure.

## Install Freno™ Modules

### C. Sequence of Module Installation.

The connecting rods should be placed in the Modules prior to installation of next Module so that the next unit can be lifted onto the connection. Level, confirm correct alignment and elevation as you go.



**Step 3:** Continue to install modules on first side.

Place a connecting rod in the end Module before placing the first side Module. Confirm the Modules are placed at a right angle to ensure correct orientation of the structure.



**Step 4:** Once the first side is completed, start installing the modules on the other side.

Install all but one Module on this side. The end Module needs to be installed before the last side Module because the side Module will rest on the end Module.



**Step 5:** Continue installing Modules on this side.

STAGE 3

## Install Freno™ Modules

### C. Sequence of Module Installation.

Adjust the end Module to provide proper spacing for placement of the last Side Module.



**Step 6:** Install the other end Module.

Here is where careful measurement and orientation of the prior modules pays off.



**Step 7:** Install the final side Module.

Detailed instructions for this step are found in the next section.



**Step 8:** Install the water intake structures using the N• Modules as shown in Stage 3-D.

## Install Freno™ Modules

### D. Building Water Intake Structures.

The foundation for the water intake structure is built as described above using T/2 Modules.

After all of the base modules have been installed and temporarily braced, and during the backfill process described in Stage 4 below, backfill the exterior of the structure near and around the intake structure with angular crushed stone, being careful to assure that the T/2 modules remain correctly aligned and level.

Place first N Module as shown in Step 8A

Place second N module in an inverted position over the first N module as shown. Adjust position to align with the top of adjacent modules as shown Step 8B.

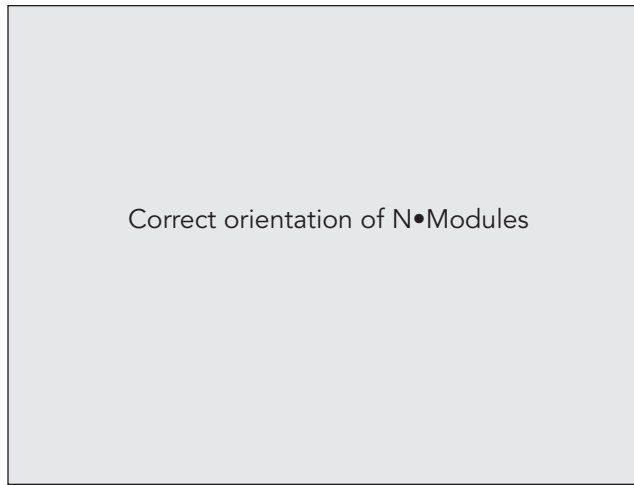

**Step 8A:** Placement of first N•Module.



**Step 7:** Placement of second N•Module.

STAGE 4

**Backfilling and Planting**

Once the modules have been installed, install the observation well, if specified, prior to commencing back fill.

Before adding bio-retention fill materials, make sure that the site is stabilized so that they will not be contaminated by excessive sedimentation in a storm event.

Backfill the excavated area outside of the structure in 8" lifts using crushed angular stone and backfill the interior of the structure with the prescribed fills (sands, aggregates, filter fabrics, and planting soils per plan) so that the inside and the outside of the system are backfilled in alternating lifts. Remove temporary shoring

Follow the plan specifications for material types and layer thicknesses of the bio-retention fill materials. Do not compact the interior fills, and consult the project designer for recommendations regarding overfill of the planting soils since approximately 20% more may be required to account for natural settlement.

As you backfill the interior, install erosion protection at the water intake locations.

Water bio-retention materials and allow to settle and adjust heights to plan specifications, as required, before adding plant materials and final mulch layer as specified.

Place plants once soils have settled. Add mulch layer to achieve final grade.



**Step 9:** Backfilling structure.



**Step 10:** Placing, Planting Soils.



Erosion control at water intake

## Paving and Finishing

The structure is now ready, but should not be placed in service until all of the drainage area has been stabilized and approved by the inspector. If there will be any delays before paving is completed, make sure sediment controls remain in place. Complete the pavement repair or placement around the structure per plan





# FRENO<sup>™</sup>

Modular Rain Garden



To order Freno<sup>™</sup>  
call 800-299-2594



A Midwest Products Group Co.

2203 E. McCarty Street  
Jefferson City MO 65101

## Nationwide Availability

The Concrete Products Group LLC (CPG) consists of regional market leaders in the concrete products industry. We offer high performance, cost effective products for the construction of buildings, stormwater management and low impact development of sites

800.789.0872

[www.concreteproductsgroup.com](http://www.concreteproductsgroup.com)