



CONCRETE MASONRY

VIEW BOOK



**MUNICIPAL
RETAIL
EDUCATIONAL**

////////////////////

**THE PERFECT FIT FOR
ALL INDUSTRIES**



DESIGNED TO INSPIRE

When you build, you want it to last a lifetime. You want it to be aesthetically pleasing while delivering superior results when it comes to moisture protection, energy efficiency and sustainability. OBERFIELDS high performance concrete masonry products are a result of a state-of-the-art manufacturing process that produces a building envelope that effectively meets or exceeds project requirements in a cost-effective manner.

That's why our tagline is Solid Performance In Concrete Products®. From our premium machine-made and precast concrete products; knowledgeable expert advice; innovative design solutions; quality control lab and color matching capabilities; and efficient on-site delivery, our products and services can take you from design phase to completion. We pledge to provide quality products, timely delivery and expert technical support.



BIG WALNUT ELEMENTARY SCHOOL

DESIGNBLOK™ SPLIT FACE

DesignBLOK® is the heart of the OBERFIELDS product line. Available in a myriad of shapes, sizes, colors and textures, OBERFIELDS DesignBLOK® units provide architects, specifiers and developers all the benefits of concrete masonry units without sacrificing any structural benefits. DesignBLOK® units are manufactured to meet current LEED requirements.



BELLVUE ELEMENTARY SCHOOL

DESIGNBLOK™ SMOOTH FACE

DesignBLOK® Smooth units can be used alone or in conjunction with our Split-Face units. Smooth units offer a relief to the split-face texture of a large wall when used as banding or accents. Smooth units can also be designed on a project when a minimalist appearance is needed. Please note that our smooth unit colors are designed as "blends" so a palette of subtle color hues are visible.





PERSONAL RESIDENCE



WEST MOUND ELEMENTARY

DESIGNBLOK™ ARTISTRY SERIES

DesignBLOK® Artistry Series veneer units offer the look of hand-cut stone, without the need for cutting or chiseling. With four different sized units per pallet, the range of patterns is unlimited and can be striking. Units offer a split-face tumbled appearance that gives a weathered look. This process allows them to be more cost-effective than natural stone and in some cases, manufactured stone. Our Artistry Series can be used on residential or commercial applications as entire wall applications or accents.



DESIGNBLOK™ ColossalBLOK®

ColossalBLOK® units are over-sized concrete masonry units that have the appearance of natural stone. Our units were designed to be a cost-effective alternative to limestone and other finishes. These high-density, pre-finished units are often used as water table applications or as decorative bands. They are available in three finishes-fine-textured smooth, split and sandblasted.





SHEARER HALL / OTTERBEIN UNIVERSITY



OBERFIELDS / DELAWARE OFFICE



DESIGNBLOK™ MILLED STONE

Our Milled Stone® line offers an upscale traditional appearance, perfect for buildings looking to mimic the craftsmanship of old. Produced in our traditional ColossalBLOK sizes (4x12x16, 4x8x24, 4x12x24), Milled Stone® is a Portland Cement-based product with fine aggregate. Product finishes include smooth, split-face and sandblasted.



DESIGNBLOK™ SANDBLAST

The Sandblast process is a method of exposing the aggregate and concrete matrix beneath the surface “skin” of concrete masonry products, allowing greater interaction between the aggregates and background color. Many Sandblast mix designs are the result of architects and producers collaborating to achieve specific appearances (granite, limestone, precast) within budget constraints. The results have been cost savings and enhanced aesthetics.





TURKEY HILL

Spec-BRIK®

Spec-BRIK® is an energy-efficient concrete masonry unit that provides a smooth, brick like texture in colors that replicate clay brick. Spec-BRIK® offers one-step installation, unlike traditional brick veneers that require structural backup. All Spec-BRIK® units are manufactured with Water Control Technology for single-wythe walls; which resists moisture penetration by diverting water downward into the wall's drainage system. All Spec-BRIK® units are mold and fire resistant and require minimal maintenance. Spec-BRIK® is just one of the many products available directly through OBERFIELDS and its partnership with the Concrete Products Group and can be specified nationwide.

R-Value and U-Factor Comparison 12" Thick Units				
Density of Block	12x4x16 Conventional Masonry (ungrouted)	12x4x16 Spec-Brik Hi-R (ungrouted)	12x4x16 Conventional Masonry (ungrouted)	12x4x16 Spec-Brik Hi-R (ungrouted)
	R-Value	R-Value	U-Factor	U-Factor
105	2.3	11.97	0.43	0.08
125	2.1	10.03	0.48	0.10

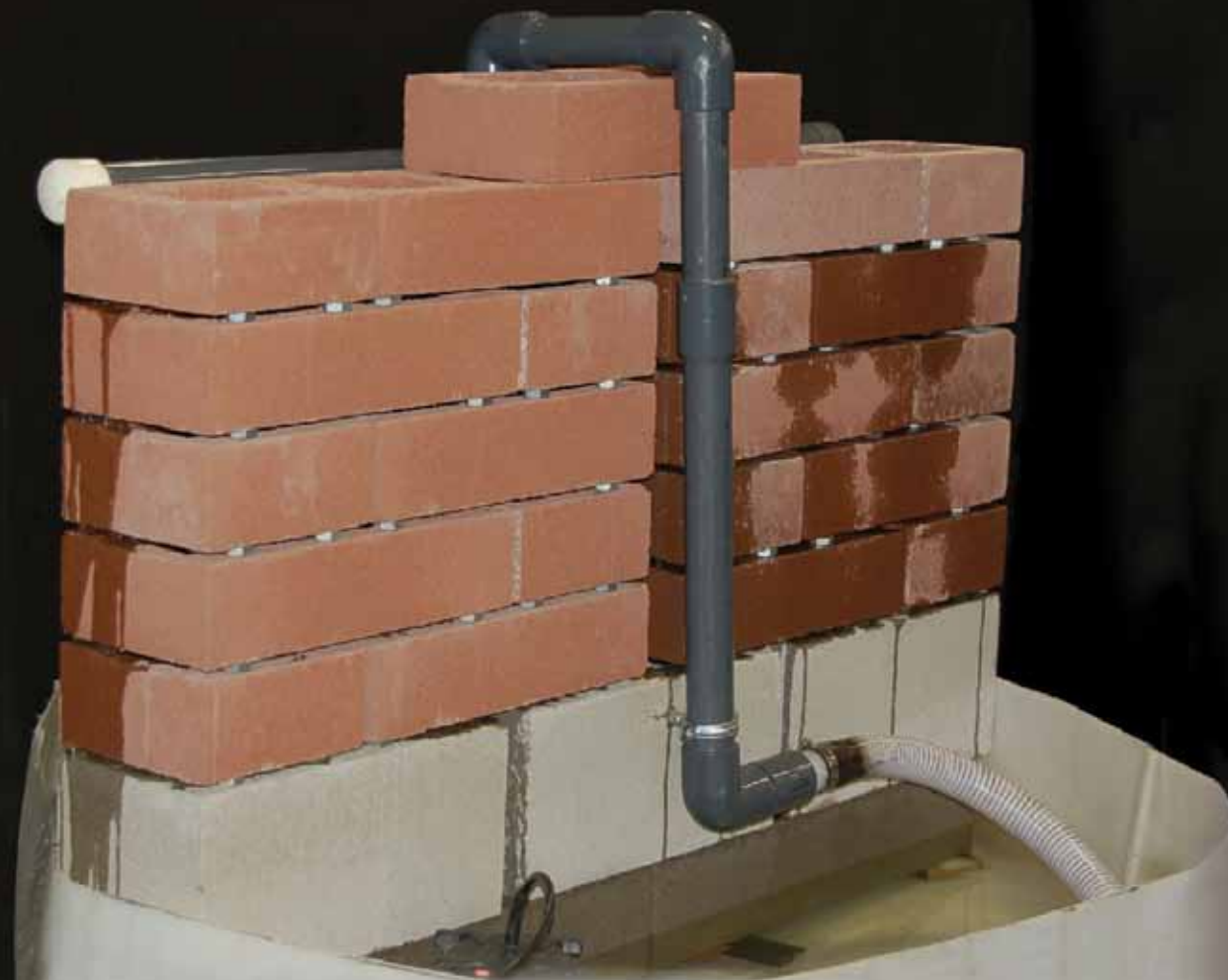

WCT WATER CONTROL TECHNOLOGY

Why try to improve one of the most trusted construction materials available? Water Control Technology (WCT) is based on preserving the superior performance characteristics of concrete masonry units while adding features that improve the ability of masonry wall assemblies to resist moisture penetration. Subtle changes were made to the top surface of each WCT units web to discourage water from crossing to the interior face shell. Corners and ends can use the WCT drainage zones without compromising aesthetics or performance. This innovation is fully compliant with ASTM C 90 and is a standard feature on all architectural masonry units produced by OBERFIELDS.

Drainage Zones

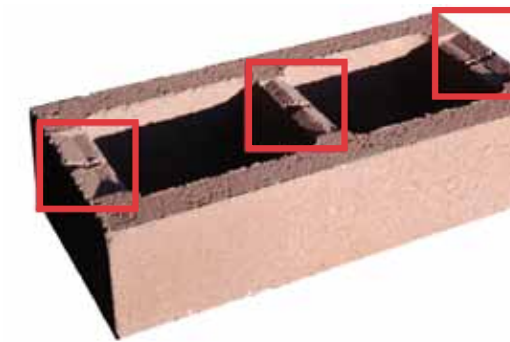



PHARMA FORCE

Spec-FINISH®

Spec-FINISH® is the perfect solution for environments where a smooth, durable and easily cleaned wall surface is required. Spec-FINISH® is a value alternative to tile and glazed block. Spec-FINISH® units are made with a special mix design to produce a tight and smooth finished block. A three-coat field applied finish provides an impermeable surface over the entire CMU wall, including mortar joint protection. Spec-FINISH® is just one of the many products available directly through OBERFIELDS and its partnership with the Concrete Products Group and can be specified nationwide.



YMCA Hilltop

Spec-THERMAL®

This Hi-R Wall System is a specially designed concrete masonry unit and individually molded insulation insert that provides industry best thermal performance in compliance with prevailing Codes and Standards. The block and the insulation are combined at the block manufacturing plant prior to delivery to the job site. The assembly provides a wall system capable of achieving higher thermal R-values than conventional masonry, while providing full code-based load resistance. Spec-THERMAL® is just one of the many products available directly through OBERFIELDS and its partnership with the Concrete Products Group and can be specified nationwide.

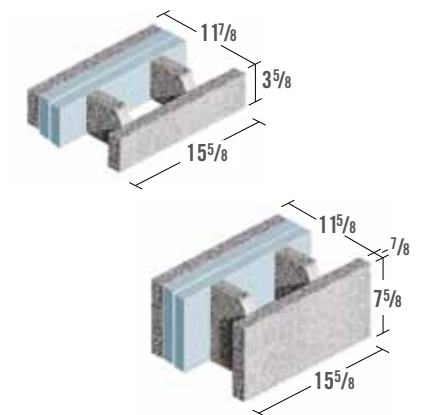



CORDOVA STONE



CHAMFERED SILLS



GROUND FACE

SPECIALTY CONCRETE MASONRY UNITS



CORDOVA STONE

CLEANING & SEALING

Good masonry practices will minimize the amount of final cleaning significantly. With this in mind, it is so important to choose a qualified concrete masonry contractor that prides themselves on workmanship and doing things the correct way.

OBERFIELDS recommends that walls be cleaned and scraped daily. Mortar droppings should be allowed to harden slightly, then scraped off with a trowel. Scaffolding boards should be turned at the end of each day, and sand or straw should be used at the base of the wall, eliminating stains that are very difficult to remove later. Masonry contractors should also cover the top of unfinished walls at the end of each day. This will prevent water from entering the cavities and will help prevent efflorescence.

Final cleaning will be easier if it occurs approximately one week after completion of walls.

Masonry contractors should never use high pressure cleaning. The use of high pressure power washes will most certainly alter the appearance of a concrete masonry wall and could cause unreparable damage to the building. A pressure washer with a maximum of 200 psi and a wide flare nozzle held 12 to 18 inches from the surface will give excellent results on most projects. Pre-wetting walls is a necessary first step. Work in sections from top down for best results.

For information about chemical cleaning-oil stains, grease, graffiti or efflorescence removal, please contact OBERFIELDS directly for our recommended cleaning solutions.

PARTNERSHIP WITH CPG

The Concrete Products Group consists of regional market leaders in the concrete products industry. By joining our efforts, the producers that comprise CPG can meet local market needs as well as service national accounts by providing consistent, top-quality products to regional and national customers.





OBERFIELDS.COM 

SALES CORPORATE OFFICE

MASONRY, LANDSCAPE & PRECAST

528 London Road
P.O. Box 362
Delaware, Ohio 43015-0362
614.252.0955
740.369.7644
800.845.7644

SALES & MANUFACTURING

LANDSCAPE & PRECAST

1165 Alum Creek Drive
Columbus, OH 43209
614.252.0955

SALES & MANUFACTURING

MASONRY & LANDSCAPE

10075 Sheehan Road
Centerville, OH 45458
937.885.3711