

5.75"

APPROVED AS SHOWN

APPROVED AS NOTED.

APPROVED BY: \_\_\_\_\_

DATE APPROVED: // //

THIS DRAWING WITH ITS PRINCIPLES OF DESIGN CONTAINS PROPRIETARY AND CONFIDENTIAL INFORMATION OF OBERFIELD'S NOT TO BE USED, COPIED OR DISCLOSED WITHOUT WRITTEN PERMISSION PROTECTED UNDER U.S. AND FOREIGN COPYRIGHT LAW. ALL RIGHTS RESERVED.



**OBERFIELDS LLC**<sup>®</sup>  
 SOLID PERFORMANCE  
 IN CONCRETE PRODUCTS<sup>®</sup>

**CONCRETE MASONRY PRODUCT GUIDE**

15.125"

## NOTES

A

- Safety
- Technical Support
- Fire Ratings
- Unit Weight
- Sandblasted Concrete Masonry Units
- Scored Concrete Masonry Units
- Combination Cubes
- West Cubes
- Obtaining Samples
- Product Disclaimer
- Handling DesignBLOK™ Architectural Concrete Masonry Units on the Job

## STANDARD CONCRETE MASONRY 1-11

- Miscellaneous Units 1
- Concrete Brick 1
- 4" Units and 4" Bullnose Units 1-2
- 6" Units and 6" Bullnose Units 2-4
- 8" Units and 8" Bullnose Units 4-7
- 10" Units and 10" Bullnose Units 7-8
- 12" Units and 12" Bullnose Units 8-10
- 14" and 16" Units 10-11

## DESIGNBLOK™ ARCHITECTURAL CONCRETE MASONRY 11-20

- Split Face Units 11-14
- Scored Split Face Units 14-15
- 3 Flute Split Face Units 15
- Deep 4 Flute Split Face Units 16
- Wide 4 Flute Split Face Units 16-17
- 6 Flute Split Face Units 17
- 8 Flute Split Face Units 17-18
- Solid Chamfered Sill Units 18
- ColossalBLOK™ Series 18-19
- SoundBLOX® 19-20
- Azar Mortarless Dry-Stack® 20
- Hi R Energy Wall System 20
- Artistry Series 21

## CORNER AND PIER DETAILS 22-23

## ESTIMATING GUIDES 24-25

## DESIGNSTONE AUTO CAD DRAWINGS 26-27

## CONCRETE LINTELS 28

## WATER CONTROL TECHNOLOGY 29

## MASONRY DESIGN SERVICE 30-32

# NOTES

## SAFETY

All OBERFIELDS concrete masonry units are manufactured in accordance with ASTM C-90, the industry standard for load bearing concrete masonry units.

Material Safety Data Sheets (MSDS) are available upon request from OBERFIELDS for the products listed in this Guide.



Please note, sawing or grinding of concrete masonry units may result in the release of dust particles, which could cause minor eye or nose irritation if proper protective equipment is not in place. The use of a NIOSH approved respirator and tight goggles is recommended when sawing or grinding operations are in progress. Please contact our Customer Service Center if further information is desired.

## TECHNICAL SUPPORT

OBERFIELDS Technical Support Staff will gladly provide written quotations for all your special project needs. To expedite the process, have any dimensional constraints, drawings, and product requirements available for our review.

## FIRE RATING

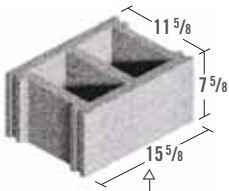
The fire ratings for the concrete masonry units in this Guide were calculated using the equivalent thickness method and based on the use of normal weight aggregates. References include ASTM C90, ASTM C140, TEK 7-1E, International Building Code 2009, and ASTM E119.

Product Description	<b>122</b>	<b>12" x 8" x 16" STRETCHER</b>
Product Number		
Product Dimensions Inches/Millimeters	<b>12" x 8" x 16"</b> 305 x 203 x 406	
Ordering Information	<b>UNIT WEIGHT: 51</b> <b>STANDARD CUBE</b> <b>66 PER CUBE</b>	
Fire Rating	 <b>RATED 3 HOURS</b>	

## PACKAGE/CUBE CODE

- On pallet - 48" x 48" returnable wood pallet
- On 8s - 18 8" x 8" x 16" hollow core units
- Standard cube - these units are cubed on themselves

Combination cube - contains different shapes in the same cube



## UNIT WEIGHT

All weights shown represent OBERFIELDS standard normal weight (Rite-Blok) concrete masonry units manufactured from natural aggregates. Most shapes and sizes can be special ordered in lightweight (Lite-Blok) or medium weight (Mid-Blok). Please contact OBERFIELDS Technical Support Staff for additional information.

To estimate a given product's weight using lightweight or medium weight raw materials, use the following rule of thumb:

- Weight of lightweight product = standard normal weight x .85
- To obtain weight of normal weight product without limestone aggregate use normal weight x 1.05

**NOTE: Weight of units manufactured at our Centerville location will vary in weight as specified in this catalog. Please call for exact weight of units.**

## SANDBLASTED CONCRETE MASONRY UNITS

Sandblasted concrete masonry units are available upon special order. Sandblasted units are manufactured such that the face surface of the unit is sandblasted. OBERFIELDS Technical Support Staff will gladly discuss design options and availability.

## SCORED CONCRETE MASONRY UNITS

OBERFIELDS offers vertical scores, or false joints, on the majority of its standard concrete masonry units. Typically, one or three scores are preferred. Also, in some instances, both sides of the standard concrete masonry unit can be scored. OBERFIELDS Technical Support Staff will gladly discuss design options and availability.



## COMBINATION CUBES

Please note on combination cubes that the ratio of one product to another varies from manufacturing plant to manufacturing plant due to differences in mold sizes and configurations. Please call our Technical Support Staff for additional information.

## WEST CUBES

West cubes are available for some concrete masonry units. Please contact our Technical Support Staff for availability.

## OBTAINING SAMPLES

Samples of colors, textures, weights, sizes, and shapes can be obtained from OBERFIELDS.

## PRODUCT DISCLAIMER

The products shown in this Guide are computer-generated images. These images depict standard gray units. Some color differentiation should be expected with architectural concrete masonry units both smooth & split. Variations are to be expected. Should you require a product not cataloged in this Guide, contact our Technical Support Staff for the manufacturing lead time.

## HANDLING DESIGNBLOK™ ARCHITECTURAL CONCRETE MASONRY UNITS ON THE JOB

When handling DesignBLOK™ architectural concrete masonry units on the job, avoid stacking palletized cubes one on top of the other. Pallet stain may occur other-wise. Also, given the demand for multiple colored units on the job, prevent the mixing of colors by checking for changes in colors of the units.



## ORDERING SUGGESTIONS

The aesthetic beauty and structural characteristics that concrete masonry possess are being recognized and appreciated. It is important that units are ordered correctly the first time to insure the lowest overall cost, while achieving the finest quality and appearance.

1. Check for changes in quantity and color. With multiple colors, due to the use of accent bands and other color combinations, ordering by OBERFIELDS name and number will help to clarify your order.
2. By using OBERFIELDS Concrete Masonry Product Guide, you can order by OBERFIELDS product number to avoid confusion. If the need arises for a shape or size that is not currently cataloged, check with your salesperson or our Technical Support Staff for the manufacturing lead time. OBERFIELDS invites your requests for custom shapes, sizes, aggregates, textures, weights, and colors.
3. For special orders, contact OBERFIELDS Customer Service Department for lead time.
4. Special units such as corners and halves, correctly ordered at the beginning of the project, will aid in color uniformity.



**MISCELLANEOUS**

**4** 16" x 16" x 8" CHIMNEY

16" x 16" x 8"  
406 x 406 x 203  
UNIT WEIGHT: 61  
ON PALLET  
45 PER CUBE

**CONCRETE BRICK**

**4"**

**12** 4" x 8" x 12" SOLID

4" x 8" x 12"  
102 x 203 x 305  
UNIT WEIGHT: 23  
ON PALLET  
144 PER CUBE

**14a** 4" x 8" x 16" SOLID L CORNER & END

4" x 8" x 16"  
102 x 203 x 406  
UNIT WEIGHT: 31  
ON PALLET  
108 PER CUBE  
**NON-STOCK**

**1** 2" x 8" x 16" SOLID

2" x 8" x 16"  
51 x 203 x 406  
UNIT WEIGHT: 14  
ON PALLET  
216 PER CUBE

**5** 16" x 20" x 8" CHIMNEY

16" x 20" x 8"  
406 x 508 x 203  
UNIT WEIGHT: 75  
ON PALLET  
30 PER CUBE

**8** 2" x 4" x 8" CONCRETE BRICK

2" x 4" x 8"  
51 x 102 x 203  
UNIT WEIGHT: 5  
ON PALLET  
720 PER CUBE

**10** 4" x 4" x 16" SOLID FROGGED ON TOP

4" x 4" x 16"  
102 x 102 x 406  
UNIT WEIGHT: 15  
ON PALLET  
216 PER CUBE

**13** 4" x 8" x 16" SOLID

4" x 8" x 16"  
102 x 203 x 406  
UNIT WEIGHT: 31  
ON PALLET OR ON 8s  
108 PER CUBE

**RATED 1.5 HOURS**

**15** 4" x 4" x 16" DOUBLE END

4" x 4" x 16"  
102 x 102 x 406  
UNIT WEIGHT: 12  
**NON-STOCK**

ON PALLET 288 PER CUBE

**3** 3" x 8" x 16" SOLID

3" x 8" x 16"  
76 x 203 x 406  
UNIT WEIGHT: 22  
ON PALLET  
144 PER CUBE

**RATED .75 HOURS**

**6** 10" x 20" x 8" CHIMNEY HALF BLOCK FOR 20" x 20" x 8"

10" x 20" x 8"  
254 x 508 x 203  
UNIT WEIGHT: 56  
ON PALLET  
40 PER CUBE

**9** 4" x 5" x 8" CONCRETE DOUBLE BRICK

4" x 5" x 8"  
102 x 127 x 203  
UNIT WEIGHT: 10  
ON PALLET  
378 PER CUBE

**11** 4" x 8" x 8" SOLID

4" x 8" x 8"  
102 x 203 x 203  
UNIT WEIGHT: 15  
ON PALLET  
216 PER CUBE

**14** 4" SOLID 45 DEGREE

4" x 8" x 11" x 3"  
102 x 203 x 280 x 76  
UNIT WEIGHT: 28  
ON PALLET  
90 PER CUBE

**16** 4" x 4" x 16" DOUBLE END BREAKER



**18** 4" x 6" x 16" DOUBLE END

4" x 6" x 16"  
102 x 152 x 406  
UNIT WEIGHT: 15  
NON-STOCK

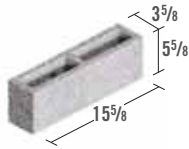

ON PALLET 216 PER CUBE

**19** 4" x 6" x 16" DOUBLE END BREAKER

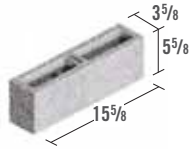

**21** 4" x 8" x 8" DOUBLE END

4" x 8" x 8"  
102 x 203 x 203  
UNIT WEIGHT: 11  
ON PALLET  
216 PER CUBE

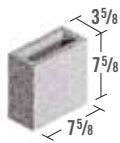

**22** 4" x 8" x 12" DOUBLE END

4" x 8" x 12"  
102 x 203 x 305  
UNIT WEIGHT: 16  
ON PALLET  
144 PER CUBE

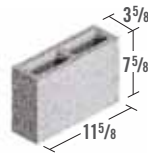

**23** 4" x 8" x 16" DOUBLE END

4" x 8" x 16"  
102 x 203 x 406  
UNIT WEIGHT: 23



RATED 1 HOUR

**24** 4" x 8" x 16" DOUBLE END BREAKER

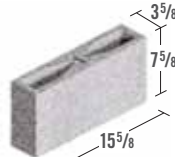

4" x 8" x 16"  
102 x 203 x 406  
UNIT WEIGHT: 24

RATED 1 HOUR

**4" BULLNOSE**

**25** 4" x 8" x 8" SOLID SINGLE BULLNOSE & END

4" x 8" x 8"  
102 x 203 x 203  
UNIT WEIGHT: 16  
ON PALLET  
216 PER CUBE

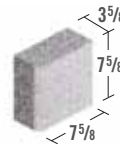

**27** 4" x 8" x 8" SINGLE BULLNOSE & END

4" x 8" x 8"  
102 x 203 x 203  
UNIT WEIGHT: 11  
ON PALLET  
216 PER CUBE



**28** 4" x 8" x 8" DOUBLE BULLNOSE & END

4" x 8" x 8"  
102 x 203 x 203  
UNIT WEIGHT: 11  
ON PALLET  
216 PER CUBE



**29** 4" x 8" x 12" SINGLE BULLNOSE & END

4" x 8" x 12"  
102 x 203 x 305  
UNIT WEIGHT: 16  
ON PALLET  
144 PER CUBE

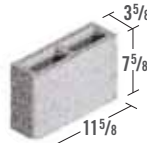

**30** 4" x 8" x 16" SINGLE BULLNOSE & END

4" x 8" x 16"  
102 x 203 x 406  
UNIT WEIGHT: 24  
ON PALLET  
144 PER CUBE



**31** 4" x 8" x 16" DOUBLE BULLNOSE & END

4" x 8" x 16"  
102 x 203 x 406  
UNIT WEIGHT: 24  
ON PALLET  
144 PER CUBE



**6"**

**32** 6" x 8" x 16" SOLID

6" x 8" x 16"  
152 x 203 x 406  
UNIT WEIGHT: 46  
ON PALLET  
72 PER CUBE

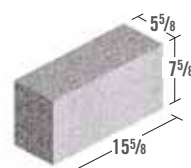

RATED 3 HOURS



**33** 6" x 4" x 16" DOUBLE END      **34** 6" x 4" x 16" DOUBLE END BREAKER      **35** 6" x 4" x 16" DOUBLE SASH BREAKER      **35a** 6" x 4" x 16" SASH & END

6" x 4" x 16"  
152 x 102 x 406  
UNIT WEIGHT: 14  
NON-STOCK



STANDARD CUBE 192 PER CUBE

**37** 6" x 6" x 16" DOUBLE END      **38** 6" x 6" x 16" DOUBLE END BREAKER      **39** 6" x 6" x 16" DOUBLE SASH BREAKER      **39a** 6" x 6" x 16" SASH & END

6" x 6" x 16"  
152 x 152 x 406  
UNIT WEIGHT: 19  
NON-STOCK

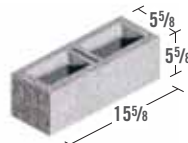
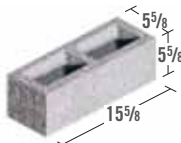

STANDARD CUBE 144 PER CUBE

**41** 6" x 8" x 8" SASH & END      **42** 6" x 8" x 14" DOUBLE END

6" x 8" x 8"  
152 x 203 x 203  
UNIT WEIGHT: 17  
ON PALLET  
216 PER CUBE

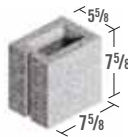

6" x 8" x 14"  
152 x 203 x 356  
UNIT WEIGHT: 23  
ON PALLET  
126 PER CUBE

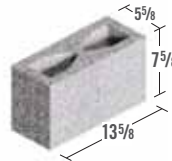

**43** 6" x 8" x 16" DOUBLE END      **44** 6" x 8" x 16" DOUBLE END BREAKER      **45** 6" x 8" x 16" SASH & END      **46** 6" x 8" x 16" DOUBLE SASH BREAKER

6" x 8" x 16"  
152 x 203 x 406  
UNIT WEIGHT: 28

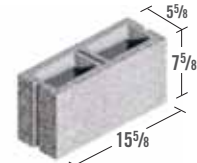
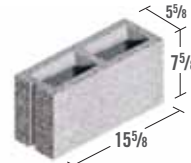
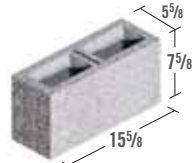
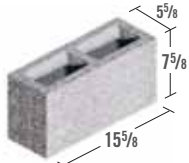

STANDARD CUBE 108 PER CUBE

**47** 6" x 8" x 16" 67% SOLID DOUBLE END

6" x 8" x 16"  
152 x 203 x 406  
UNIT WEIGHT: 34  
ON PALLET  
72 PER CUBE  
NON-STOCK

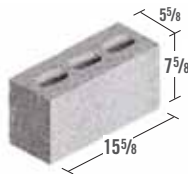

RATED 1.5 HOURS

**48** 6" x 8" x 16" U BOND BEAM

6" x 8" x 16"  
152 x 203 x 406  
UNIT WEIGHT: 28  
ON PALLET  
96 PER CUBE

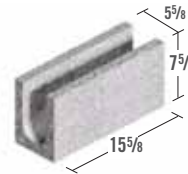

**6" BULLNOSE**

**49** 6" x 8" x 16" SOLID BULLNOSE ACROSS FACE

6" x 8" x 16"  
152 x 203 x 406  
UNIT WEIGHT: 46  
ON PALLET  
72 PER CUBE  
NON-STOCK

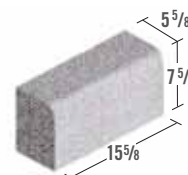

**50** 6" x 8" x 8" SINGLE BULLNOSE & END

6" x 8" x 8"  
152 x 203 x 203  
UNIT WEIGHT: 17  
ON PALLET  
216 PER CUBE

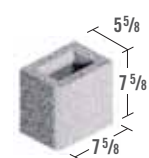



**51** 6" x 8" x 8" DOUBLE BULLNOSE & END

6" x 8" x 8"  
152 x 203 x 203  
UNIT WEIGHT: 17  
ON PALLET  
216 PER CUBE  
NON-STOCK



**52** 6" x 8" x 14" SINGLE BULLNOSE

6" x 8" x 14"  
152 x 203 x 356  
UNIT WEIGHT: 24  
ON PALLET  
126 PER CUBE  
NON-STOCK

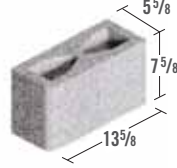

**53** 6" x 8" x 16" SINGLE BULLNOSE & END

6" x 8" x 16"  
152 x 203 x 406  
UNIT WEIGHT: 29  
ON PALLET  
108 PER CUBE

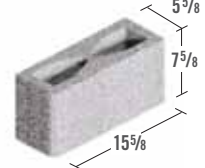

**54** 6" x 8" x 16" DOUBLE BULLNOSE & END

6" x 8" x 16"  
152 x 203 x 406  
UNIT WEIGHT: 29  
ON PALLET  
108 PER CUBE



**8" UNITS**

**55** 8" x 8" x 16" SOLID

8" x 8" x 16"  
203 x 203 x 406  
UNIT WEIGHT: 63  
ON PALLET  
54 PER CUBE

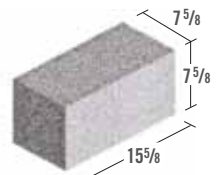

RATED 4 HOURS

**56** 8" x 8" x 16" SOLID HEADER

8" x 8" x 16"  
203 x 203 x 406  
UNIT WEIGHT: 48  
ON 8s  
72 PER CUBE

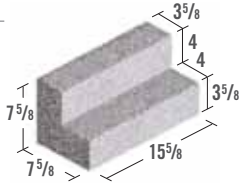

**56a** 8" x 8" x 16" OPEN CORE SOLID HEADER

8" x 8" x 16"  
203 x 203 x 406  
UNIT WEIGHT: 43  
ON (18) 8" HC/COMBINED  
(1 OUT OF 3)  
72 PER CUBE

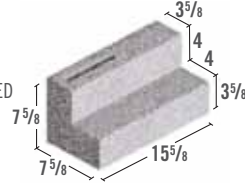

**59** 8" x 4" x 16" DOUBLE END\*

**60** 8" x 4" x 16" DOUBLE END BREAKER\*

**61** 8" x 4" x 16" SASH & END\*

**62** 8" x 4" x 16" DOUBLE SASH BREAKER\*

**63** 8" x 4" x 16" DOUBLE END\*

8" x 4" x 16"  
203 x 102 x 406  
UNIT WEIGHT: 17

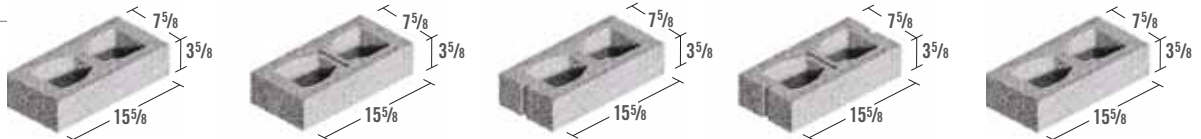

ON PALLET 144 PER CUBE

**63a** 8" x 4" x 16" RESTRICTED BOND BEAM

8" x 4" x 16"  
203 x 102 x 406  
UNIT WEIGHT: 17  
ON PALLET  
144 PER CUBE  
NON-STOCK

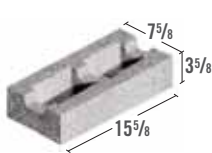

**64** 8" x 6" x 16" DOUBLE END\*

**65** 8" x 6" x 16" DOUBLE END BREAKER\*

**66** 8" x 6" x 16" SASH & END\*

**67** 8" x 6" x 16" DOUBLE SASH BREAKER\*

**67a** 8" x 6" x 16" DOUBLE END\*

8" x 6" x 16"  
203 x 152 x 406  
UNIT WEIGHT: 25

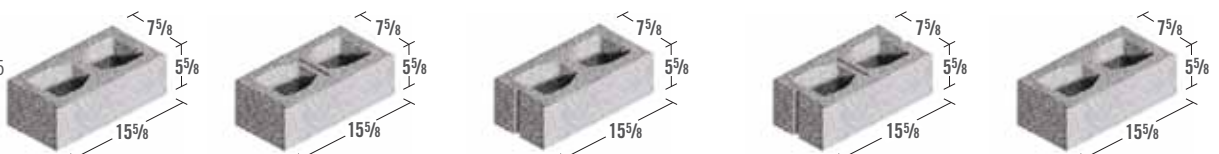

ON PALLET 108 PER CUBE

\* Architectural cubed CMU's only



<b>68a</b> 8" x 8" x 16" DOUBLE END*	<b>68b</b> 8" x 8" x 16" DOUBLE END BREAKER*	<b>68c</b> 8" x 8" x 16" SASH & END*	<b>68d</b> 8" x 8" x 16" DOUBLE SASH BREAKER*	<b>68e</b> 8" x 8" x 16" DOUBLE END*
ON PALLET 90 PER CUBE				

**69** 8" x 8" x 8" SASH & END

8" x 8" x 8"  
203 x 203 x 203  
UNIT WEIGHT: 21  
ON PALLET  
144 PER CUBE

**70** 8" x 8" x 12" DOUBLE END

8" x 8" x 12"  
203 x 203 x 305  
UNIT WEIGHT: 29  
ON PALLET  
120 PER CUBE

**71** 8" 45 DEGREE

8" x 8" x 8" x 11"  
203 x 203 x 203 x 279  
UNIT WEIGHT: 29  
ON PALLET  
120 PER CUBE

**72** 8" x 8" x 16" STRETCHER

8" x 8" x 16"  
203 x 203 x 406  
UNIT WEIGHT: 34

RATED 2 HOURS

**73** 8" x 8" x 16" SASH & END

8" x 8" x 16"  
203 x 203 x 406  
UNIT WEIGHT: 35

RATED 2 HOURS

**74** 8" x 8" x 16" 2 HOUR STRETCHER

8" x 8" x 16"  
203 x 203 x 406  
UNIT WEIGHT: 36

RATED 2 HOURS

**75** 8" x 8" x 16" 2 HOUR SASH & END

8" x 8" x 16"  
203 x 203 x 406  
UNIT WEIGHT: 36

RATED 2 HOURS

**76** 8" x 8" x 16" 3 HOUR STRETCHER

8" x 8" x 16"  
203 x 203 x 406  
UNIT WEIGHT: 42

RATED 3 HOURS

**77** 8" x 8" x 16" 3 HOUR SASH & END BREAKER

8" x 8" x 16"  
203 x 203 x 406  
UNIT WEIGHT: 44

RATED 3 HOURS

**78** 8" x 8" x 16" 4 HOUR STRETCHER

8" x 8" x 16"  
203 x 203 x 406  
UNIT WEIGHT: 49  
NON-STOCK

RATED 4 HOURS

**79** 8" x 8" x 16" 4 HOUR SASH & END BREAKER

8" x 8" x 16"  
203 x 203 x 406  
UNIT WEIGHT: 51  
NON-STOCK

RATED 4 HOURS

**80** 8" x 8" x 16" DOUBLE END

8" x 8" x 16"  
203 x 203 x 406  
UNIT WEIGHT: 36  
ON PALLET  
90 PER CUBE

\*Architectural cubed CMU's only



**81** 8" x 8" x 16" SASH & END BREAKER

8" x 8" x 16"  
203 x 203 x 406  
UNIT WEIGHT: 36  
ON PALLET  
90 PER CUBE

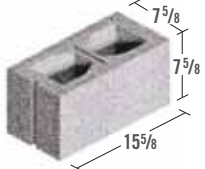

**82** 8" x 8" x 16" WEEP

8" x 8" x 16"  
203 x 203 x 406  
UNIT WEIGHT: 33  
STANDARD CUBE  
90 PER CUBE

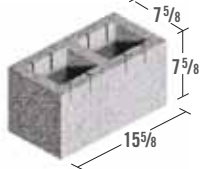

**83** 8" x 8" x 16" TERMITE

8" x 8" x 16"  
203 x 203 x 406  
UNIT WEIGHT: 43

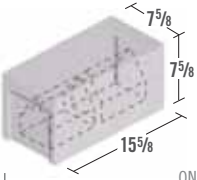

ON (18) 8" HC

**84** 8" x 8" x 16" TERMITE SASH & END BREAKER

8" x 8" x 16"  
203 x 203 x 406  
UNIT WEIGHT: 50

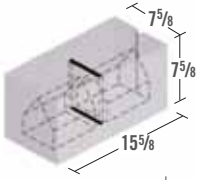

**84a** 8" x 8" x 16" OPEN CELL TERMITE

8" x 8" x 16"  
203 x 203 x 406  
UNIT WEIGHT: 38  
ON (18) 8" HC  
72 PER CUBE

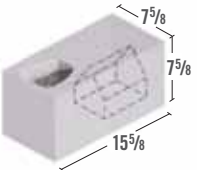

**85** 8" x 8" x 16" U SOLID BOTTOM BOND BEAM

8" x 8" x 16"  
203 x 203 x 406  
UNIT WEIGHT: 45  
ON PALLET  
90 PER CUBE

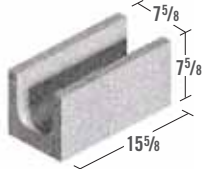

**86** 8" x 8" x 16" OPEN BOTTOM BOND BEAM 2 SLOT

8" x 8" x 16"  
203 x 203 x 406  
UNIT WEIGHT: 37  
ON PALLET  
90 PER CUBE

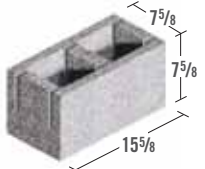

**87** 8" x 8" x 16" RESTRICTED BOND BEAM

8" x 8" x 16"  
203 x 203 x 406  
UNIT WEIGHT: 32  
ON PALLET  
90 PER CUBE

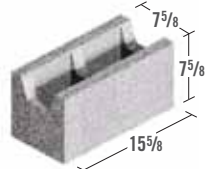

**88** 8" x 8" x 16" GROUT

8" x 8" x 16"  
203 x 203 x 406  
UNIT WEIGHT: 34  
ON PALLET  
90 PER CUBE

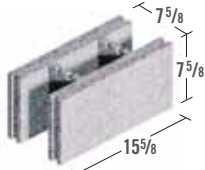

**88a** 8" x 8" x 16" OPEN END REBAR

8" x 8" x 16"  
203 x 203 x 406  
UNIT WEIGHT: 33  
ON PALLET  
90 PER CUBE

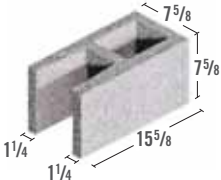

**88b** 8" x 8" x 16" DOUBLE OPEN END BOND BEAM

8" x 8" x 16"  
203 x 203 x 406  
UNIT WEIGHT: 32  
ON PALLET  
90 PER CUBE

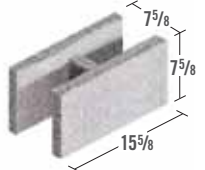

**88c** 8" x 8" x 16" BEAM INTEL

8" x 8" x 16"  
203 x 203 x 406  
UNIT WEIGHT: 36  
ON PALLET  
90 PER CUBE  
NON-STOCK

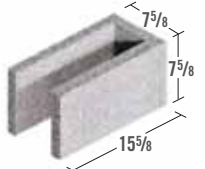

**89** 8" x 8" x 16" KNOCK-OUT PIPE CHASE

8" x 8" x 16"  
203 x 203 x 406  
UNIT WEIGHT: 35  
ON PALLET  
90 PER CUBE

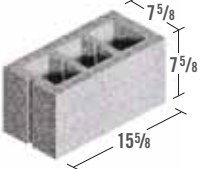

**89a** 8" x 8" x 24" HOLLOW CORE

8" x 8" x 24"  
203 x 203 x 610  
UNIT WEIGHT: 51  
ON PALLET  
60 PER CUBE  
NON-STOCK

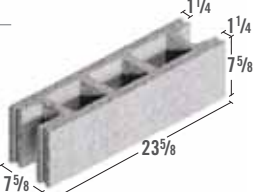

**89b** 8" x 8" x 20" CORNER/STRETCHER

8" x 8" x 20"  
203 x 203 x 508  
UNIT WEIGHT: 48  
ON PALLET  
60 PER CUBE  
NON-STOCK

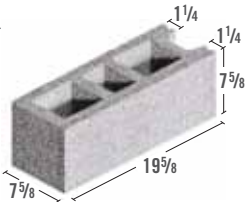

**89c** 8" x 8" x 12" 1/2 SASH/STRETCHER

8" x 8" x 12"  
203 x 203 x 305  
UNIT WEIGHT: 28  
40 PER CUBE  
NON-STOCK

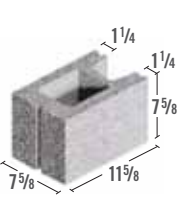

ON PALLET 80 PER CUBE

**89d** 8" x 8" x 24" HOLLOW CORE SASH/STRETCHER

8" x 8" x 24"  
203 x 203 x 610  
UNIT WEIGHT: 53  
40 PER CUBE  
NON-STOCK

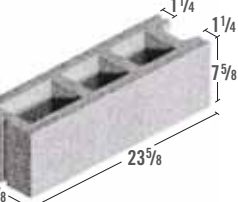



**89e** 8" x 8" x 12" END/STRETCHER

8" x 8" x 12"  
203 x 203 x 305  
UNIT WEIGHT: 28  
40 PER CUBE  
**NON-STOCK**

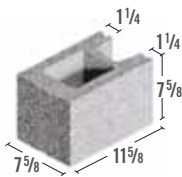

**89f** 8" x 8" x 24" HOLLOW CORE END/STRETCHER

8" x 8" x 24"  
203 x 203 x 610  
UNIT WEIGHT: 53  
40 PER CUBE  
**NON-STOCK**

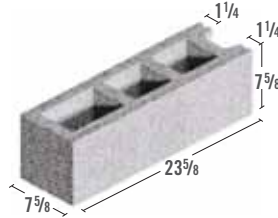

ON PALLET 80 PER CUBE

**91** 8" x 8" x 8" SINGLE BULLNOSE & END

8" x 8" x 8"  
203 x 203 x 203  
UNIT WEIGHT: 21  
ON PALLET  
144 PER CUBE

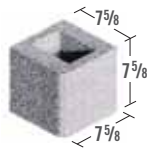

**92** 8" x 8" x 8" DOUBLE BULLNOSE & END

8" x 8" x 8"  
203 x 203 x 203  
UNIT WEIGHT: 21  
ON PALLET  
144 PER CUBE

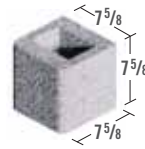

**94** 8" x 8" x 16" DOUBLE BULLNOSE & END

8" x 8" x 16"  
203 x 203 x 406  
UNIT WEIGHT: 38  
ON PALLET  
90 PER CUBE

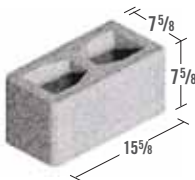

**95** 8" x 8" x 8" SASH ON SINGLE BULLNOSE & END

8" x 8" x 8"  
203 x 203 x 203  
UNIT WEIGHT: 21  
ON PALLET  
144 PER CUBE  
**NON-STOCK**

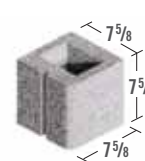

**97** 8" x 8" x 16" SASH ON SINGLE BULLNOSE & STRETCHER BREAKER

8" x 8" x 16"  
203 x 203 x 406  
UNIT WEIGHT: 38  
ON PALLET  
90 PER CUBE  
**NON-STOCK**

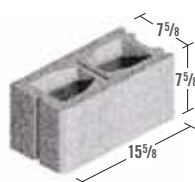

**98** 8" x 8" x 16" SASH ON DOUBLE BULLNOSE & STRETCHER BREAKER

8" x 8" x 16"  
203 x 203 x 406  
UNIT WEIGHT: 38  
ON PALLET  
90 PER CUBE  
**NON-STOCK**

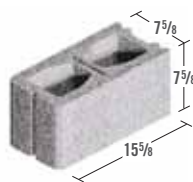

**99** 8" x 8" x 16" BULLNOSE DOUBLE END (PILASTER)

**8" BULLNOSE**

**93** 8" x 8" x 16" SINGLE BULLNOSE & END

8" x 8" x 16"  
203 x 203 x 406  
UNIT WEIGHT: 38  
ON PALLET  
90 PER CUBE

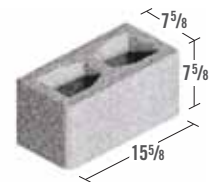

**100** 10" x 4" x 16" SOLID

10" x 4" x 16"  
254 x 102 x 406  
UNIT WEIGHT: 41  
ON PALLET  
90 PER CUBE  
**NON-STOCK**

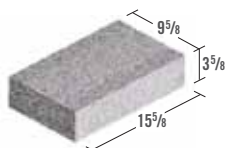

**10"**

**101** 10" x 8" x 16" SOLID

10" x 8" x 16"  
254 x 203 x 406  
UNIT WEIGHT: 84  
ON PALLET  
45 PER CUBE  
**NON-STOCK**  
RATED 4 HOURS

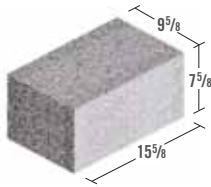

**102** 10" x 4" x 16" STRETCHER

10" x 4" x 16"  
254 x 102 x 406  
UNIT WEIGHT: 23  
**NON-STOCK**

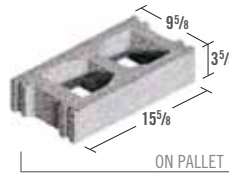

**103** 10" x 4" x 16" SASH & END BREAKER

10" x 4" x 16"  
254 x 102 x 406  
UNIT WEIGHT: 23  
**NON-STOCK**

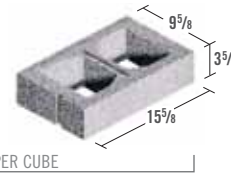

ON PALLET 120 PER CUBE

**104** 10" x 8" x 8" SASH & END

10" x 8" x 8"  
254 x 203 x 203  
UNIT WEIGHT: 25  
ON PALLET  
90 PER CUBE

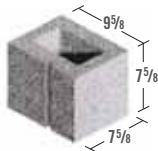

**105** 10" x 8" x 16" STRETCHER

10" x 8" x 16"  
254 x 203 x 406  
UNIT WEIGHT: 44

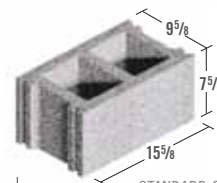

RATED 3 HOURS

**106** 10" x 8" x 16" SASH & END BREAKER

10" x 8" x 16"  
254 x 203 x 406  
UNIT WEIGHT: 48

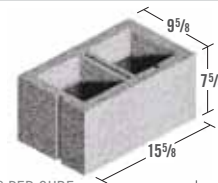

RATED 3 HOURS

STANDARD CUBE 72 PER CUBE

**107** 10" x 8" x 16" WEEP

10" x 8" x 16"  
254 x 203 x 406  
UNIT WEIGHT: 46  
STANDARD CUBE  
72 PER CUBE

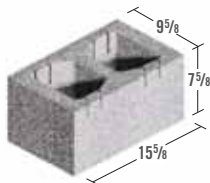

**108** 10" x 8" x 16" OPEN BOTTOM BOND BEAM

10" x 8" x 16"  
254 x 203 x 406  
UNIT WEIGHT: 48  
STANDARD CUBE  
75 PER CUBE  
**NON-STOCK**

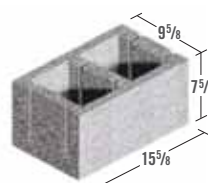

**109** 10" x 8" x 16" TERMITE OR BOND BEAM

10" x 8" x 16"  
254 x 203 x 406  
UNIT WEIGHT: 50  
ON PALLET  
60 PER CUBE

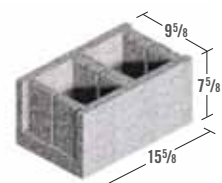

**110** 10" x 8" x 16" RETURN CORNER

10" x 8" x 16"  
254 x 203 x 406  
UNIT WEIGHT: 43  
ON PALLET  
72 PER CUBE

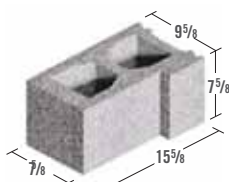

**111** 10" x 8" x 16" KNOCK-OUT PIPE CHASE

10" x 8" x 16"  
254 x 203 x 406  
UNIT WEIGHT: 48  
ON PALLET  
75 PER CUBE

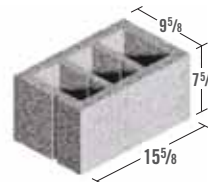

**10" BULLNOSE**

**112** 10" x 8" x 8" SINGLE BULLNOSE & END

10" x 8" x 8"  
254 x 203 x 203  
UNIT WEIGHT: 25  
ON PALLET  
90 PER CUBE

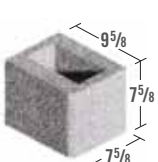

**113** 10" x 8" x 16" SINGLE BULLNOSE & END

10" x 8" x 16"  
254 x 203 x 406  
UNIT WEIGHT: 50  
ON PALLET  
75 PER CUBE

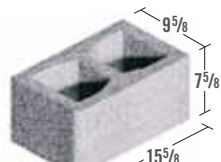

**114** 10" x 8" x 16" DOUBLE BULLNOSE & END

10" x 8" x 16"  
254 x 203 x 406  
UNIT WEIGHT: 50  
ON PALLET  
75 PER CUBE

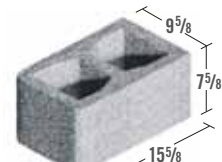

**12"**

**115** 12" x 4" x 16" SOLID

12" x 4" x 16"  
305 x 102 x 406  
UNIT WEIGHT: 48  
ON PALLET  
72 PER CUBE

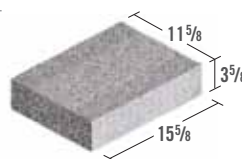

**116** 12" x 8" x 16" SOLID

12" x 8" x 16"  
305 x 203 x 406  
UNIT WEIGHT: 99  
ON PALLET  
36 PER CUBE

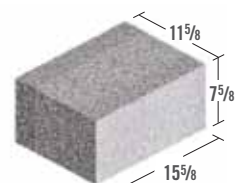

RATED 4 HOURS



**117a** 12" x 4" x 16" DOUBLE END **117a** 12" x 4" x 16" DOUBLE END **118** 12" x 4" x 16" SASH & END BREAKER

12" x 4" x 16"  
305 x 102 x 406  
UNIT WEIGHT: 23

ON PALLET 120 PER CUBE

**118a** 12" x 4" x 16" RESTRICTED BOND BEAM

12" x 4" x 16"  
305 x 102 x 406  
UNIT WEIGHT: 24  
ON PALLET  
120 PER CUBE

**119** 12" x 8" x 8" SASH & END

12" x 8" x 8"  
305 x 203 x 203  
UNIT WEIGHT: 29  
ON PALLET  
120 PER CUBE

**120** 12" x 8" x 12" DOUBLE END

12" x 8" x 12"  
305 x 203 x 305  
UNIT WEIGHT: 41  
ON PALLET  
80 PER CUBE

**121** 12" 45 DEGREE

12" x 8" x 8" x 13"  
305 x 203 x 203 x 330  
UNIT WEIGHT: 42  
ON PALLET  
60 PER CUBE

**122** 12" x 8" x 16" STRETCHER

12" x 8" x 16"  
305 x 203 x 406  
UNIT WEIGHT: 51  
STANDARD CUBE  
OR ON PALLET  
66 PER CUBE  
 RATED 3 HOURS

**123** 12" x 8" x 16" STRETCHER (THREE CORE)

12" x 8" x 16"  
305 x 203 x 406  
UNIT WEIGHT: 53  
ON PALLET  
60 PER CUBE  
**NON-STOCK**  
 RATED 4 HOURS

**124** 12" x 8" x 16" DOUBLE END

12" x 8" x 16"  
305 x 203 x 406  
UNIT WEIGHT: 47  
STANDARD CUBE  
60 PER CUBE

**125** 12" x 8" x 16" SASH & END BREAKER

12" x 8" x 16"  
305 x 203 x 406  
UNIT WEIGHT: 55  
ON PALLET  
60 PER CUBE

**125a** 12" x 8" x 16" DOUBLE END\* **125b** 12" x 8" x 16" SASH & END BREAKER\* **125c** 12" x 8" x 16" DOUBLE END\*

12" x 8" x 16"  
305 x 203 x 406  
UNIT WEIGHT: 55

ON PALLET 60 PER CUBE

**126** 12" x 8" x 16" WEEP

12" x 8" x 16"  
305 x 203 x 406  
UNIT WEIGHT: 47  
STANDARD CUBE  
72 PER CUBE

**127** 12" x 8" x 16" TERMITE

12" x 8" x 16"  
305 x 203 x 406  
UNIT WEIGHT: 64

ON PALLET 60 PER CUBE

**128** 12" x 8" x 16" TERMITE SASH & END BREAKER

12" x 8" x 16"  
305 x 203 x 406  
UNIT WEIGHT: 66

**129** 12" x 8" x 16" DOUBLE END TERMITE

12" x 8" x 16"  
305 x 203 x 406  
UNIT WEIGHT: 77  
ON PALLET  
60 PER CUBE

**130** 12" x 8" x 16" TERMITE OR BOND BEAM

12" x 8" x 16"  
305 x 203 x 406  
UNIT WEIGHT: 59  
ON PALLET  
60 PER CUBE

**131** 12" x 8" x 16" W BOND BEAM

12" x 8" x 16"  
305 x 203 x 406  
UNIT WEIGHT: 59  
ON PALLET  
60 PER CUBE

\*Architectural cubed CMS's only



**132** 12" x 8" x 16" OPEN BOTTOM BOND BEAM

12" x 8" x 16"  
305 x 203 x 406  
UNIT WEIGHT: 58  
ON PALLET  
60 PER CUBE

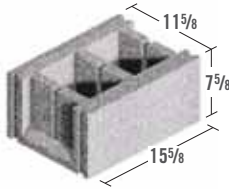

**133** 12" x 8" x 16" RESTRICTED BOND BEAM

12" x 8" x 16"  
305 x 203 x 406  
UNIT WEIGHT: 47  
ON PALLET  
60 PER CUBE

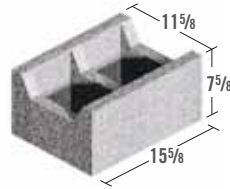

**134** 12" x 8" x 16" GROUT

12" x 8" x 16"  
305 x 203 x 406  
UNIT WEIGHT: 39  
ON PALLET  
60 PER CUBE

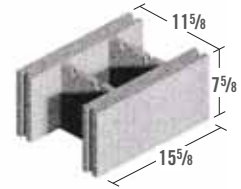

**134a** 12" x 8" x 16" OPEN END REBAR

12" x 8" x 16"  
305 x 203 x 406  
UNIT WEIGHT: 46  
ON PALLET  
60 PER CUBE

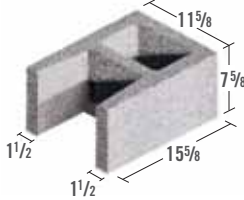

**134b** 12" x 8" x 16" DOUBLE OPEN END BOND BEAM

12" x 8" x 16"  
305 x 203 x 406  
UNIT WEIGHT: 46  
ON PALLET  
60 PER CUBE

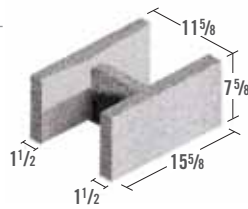

**135** 12" x 8" x 16" RETURN CORNER

12" x 8" x 16"  
305 x 203 x 406  
UNIT WEIGHT: 46  
ON PALLET  
72 PER CUBE

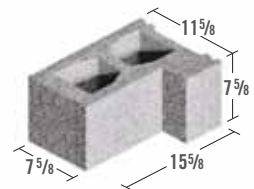

**136** 12" x 8" x 16" KNOCK-OUT PIPE CHASE

12" x 8" x 16"  
305 x 203 x 406  
UNIT WEIGHT: 55  
ON PALLET  
60 PER CUBE

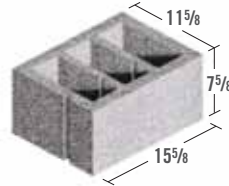

**12" BULLNOSE**

**137** 12" x 8" x 8" SINGLE BULLNOSE & END

12" x 8" x 8"  
305 x 203 x 203  
UNIT WEIGHT: 29  
ON PALLET  
120 PER CUBE

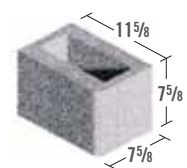

**138** 12" x 8" x 8" DOUBLE BULLNOSE & END

12" x 8" x 8"  
305 x 203 x 203  
UNIT WEIGHT: 29  
ON PALLET  
120 PER CUBE

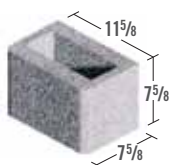

**139** 12" x 8" x 16" SINGLE BULLNOSE & END

12" x 8" x 16"  
305 x 203 x 406  
UNIT WEIGHT: 57  
ON PALLET  
60 PER CUBE

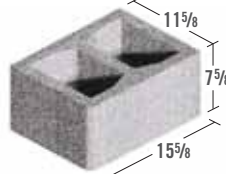

**140** 12" x 8" x 16" DOUBLE BULLNOSE & END

12" x 8" x 16"  
305 x 203 x 406  
UNIT WEIGHT: 57  
ON PALLET  
60 PER CUBE

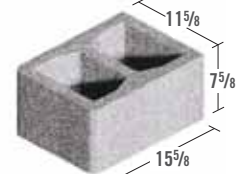

**14"**

**141** 14" x 8" x 16" STRETCHER

14" x 8" x 16"  
356 x 203 x 406  
UNIT WEIGHT: 55  
54 PER CUBE

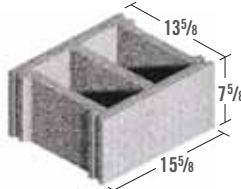

RATED 4 HOURS

**141a** 14" x 8" x 16" Termite Sash & End

14" x 8" x 16"  
356 x 203 x 406  
UNIT WEIGHT: 72  
45 PER CUBE  
Non Stock

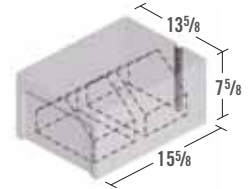

**142** 14" x 8" x 8" SASH & END

14" x 8" x 8"  
356 x 203 x 203  
UNIT WEIGHT: 33

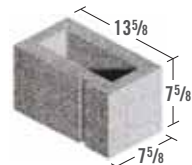

**143** 14" x 8" x 16" SASH & END

14" x 8" x 16"  
356 x 203 x 406  
UNIT WEIGHT: 58

RATED 4 HOURS

ON PALLET 30 OF EACH SHAPE PER CUBE



143a

14" x 8" x 8" SASH ON SINGLE  
BULLNOSE & END

14" x 8" x 8"  
356 x 203 x 203  
UNIT WEIGHT: 33

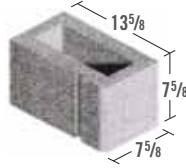

ON PALLET 30 OF EACH SHAPE PER CUBE

143b

14" x 8" x 16" SASH ON SINGLE  
BULLNOSE END

14" x 8" x 16"  
356 x 203 x 406  
UNIT WEIGHT: 53

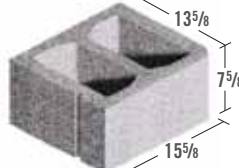

RATED 4 HOURS

144

16" x 8" x 16" STRETCHER

16" x 8" x 16"  
406 x 203 x 406  
UNIT WEIGHT: 57

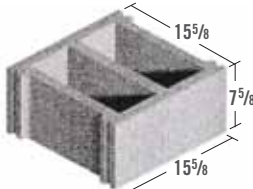

ON PALLET 45 PER CUBE

RATED 4 HOURS

145

16" x 8" x 16" SASH & END

16" x 8" x 16"  
406 x 203 x 406  
UNIT WEIGHT: 63

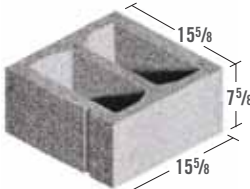

RATED 4 HOURS

145a

16" x 8" x 8" SASH & END

16" x 8" x 8"  
406 x 203 x 406  
UNIT WEIGHT: 65  
90 PER CUBE

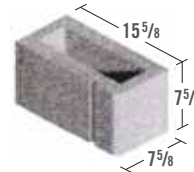

RATED 4 HOURS

**SPLIT FACE 4"**

146

4" x 3" x 8" SOLID SPLIT FACE  
CONCRETE BRICK

4" x 3" x 8"  
102 x 57 x 203  
UNIT WEIGHT: 4  
ON PALLET  
525 PER CUBE  
NON-STOCK

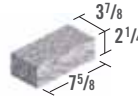

147

4" x 3" x 8" SOLID CORNER & END SPLIT FACE  
CONCRETE BRICK

4" x 3" x 8"  
102 x 57 x 203  
UNIT WEIGHT: 4  
ON PALLET  
525 PER CUBE  
NON-STOCK



148

4" x 2" x 16" SOLID SPLIT FACE

4" x 2" x 16"  
102 x 51 x 406  
UNIT WEIGHT: 7  
ON PALLET  
504 PER CUBE  
NON-STOCK

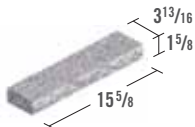

149

4" x 3" x 16" SOLID SPLIT FACE

4" x 3" x 16"  
102 x 76 x 406  
UNIT WEIGHT: 12  
ON PALLET  
288 PER CUBE  
NON-STOCK



150

4" x 4" x 12" SOLID CORNER & END SPLIT FACE

4" x 4" x 12"  
102 x 102 x 305  
UNIT WEIGHT: 12  
ON PALLET  
216 PER CUBE  
NON-STOCK



151

4" x 4" x 16" SOLID SPLIT FACE FROGGED

4" x 4" x 16"  
102 x 102 x 406  
UNIT WEIGHT: 17  
ON PALLET  
216 PER CUBE  
NON-STOCK

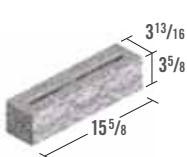

152

4" x 8" x 12" SOLID CORNER & END SPLIT FACE

4" x 8" x 12"  
102 x 203 x 305  
UNIT WEIGHT: 24  
ON PALLET  
144 PER CUBE  
NON-STOCK

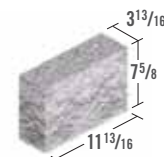

152a

4" x 8" x 16" SOLID L CORNER &  
END SPLIT FACE

4" x 8" x 16"  
102 x 203 x 406  
UNIT WEIGHT: 34  
ON PALLET  
108 PER CUBE  
NON-STOCK

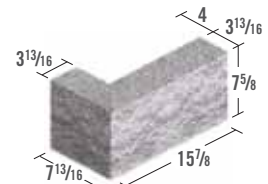

153

4" x 8" x 16" SOLID SPLIT FACE FROGGED

4" x 8" x 16"  
102 x 203 x 406  
UNIT WEIGHT: 34  
ON PALLET  
108 PER CUBE  
NON-STOCK



EVERY 3RD HAS 1 FROG TO SPLIT CORNERS IN THE FIELD



**SPLIT FACE 6"**

**156** 6" x 8" x 16" SOLID SPLIT FACE

6" x 8" x 16"  
152 x 203 x 406  
UNIT WEIGHT: 53  
ON PALLET  
72 PER CUBE  
NON-STOCK

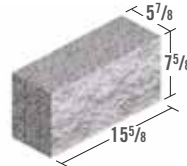

**157** 6" x 8" x 14" SOLID CORNER & END SPLIT FACE

6" x 8" x 14"  
152 x 203 x 356  
UNIT WEIGHT: 48  
ON PALLET  
72 PER CUBE  
NON-STOCK

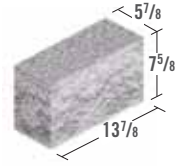

**158** 6" x 8" x 16" DOUBLE END SPLIT FACE

**159** 6" x 8" x 16" DOUBLE END BREAKER SPLIT FACE

**159a** 6" x 8" x 16" SASH & END SPLIT FACE

**159b** 6" x 8" x 16" DOUBLE SASH BREAKER

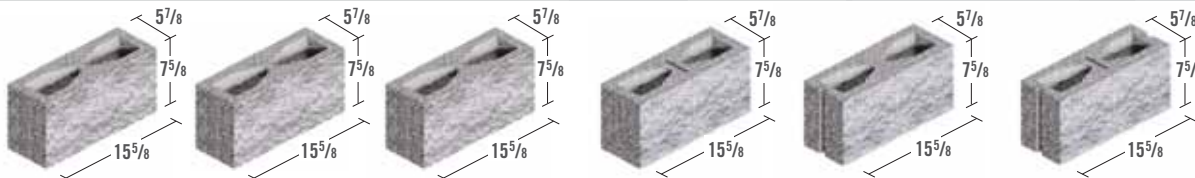

6" x 8" x 16"  
152 x 203 x 406  
UNIT WEIGHT: 37  
ON PALLET  
NON-STOCK

ALL SIX UNITS ON PALLET 96 PER CUBE

**SPLIT FACE 8"**

**160** 8" x 4" x 16" SOLID SPLIT FACE

8" x 4" x 16"  
203 x 102 x 406  
UNIT WEIGHT: 34  
ON PALLET  
108 PER CUBE  
NON-STOCK

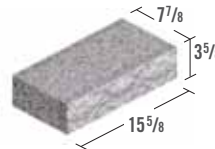

**161a** 8" x 4" x 16" DOUBLE END SPLIT FACE

**162b** 8" x 4" x 16" SASH & END SPLIT FACE

**162c** 8" x 4" x 16" DOUBLE SASH BREAKER SPLIT FACE

**162d** 8" x 4" x 16" DOUBLE END BREAKER SPLIT FACE

8" x 4" x 16"  
203 x 102 x 406  
UNIT WEIGHT: 19  
NON-STOCK

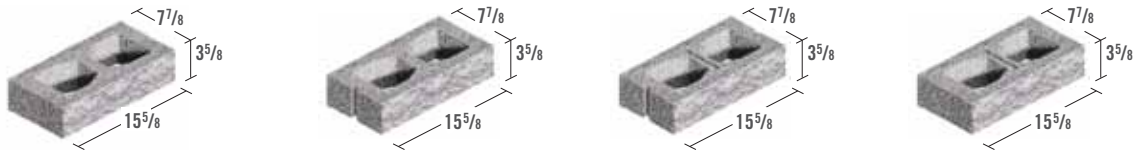

ON PALLET 144 PER CUBE

**163** 8" x 4" x 16" CORNER & END SPLIT FACE

8" x 4" x 16"  
203 x 102 x 406  
UNIT WEIGHT: 19  
ON PALLET  
120 PER CUBE  
NON-STOCK



**164** 8" x 8" x 8" SASH & END SPLIT FACE

8" x 8" x 8"  
203 x 203 x 203  
UNIT WEIGHT: 22  
ON PALLET  
144 PER CUBE



**167a** 8" x 8" x 16" DOUBLE END SPLIT FACE

**167b** 8" x 8" x 16" SASH & END SPLIT FACE

**167c** 8" x 8" x 16" DOUBLE SASH BREAKER SPLIT FACE

**167d** 8" x 8" x 16" DOUBLE END BREAKER SPLIT FACE

8" x 8" x 16"  
203 x 203 x 406  
UNIT WEIGHT: 42



ON PALLET 90 PER CUBE



### 169 8" x 8" x 16" CORNER & END SPLIT FACE

8" x 8" x 16"

203 x 203 x 406  
UNIT WEIGHT: 45  
ON PALLET  
90 PER CUBE

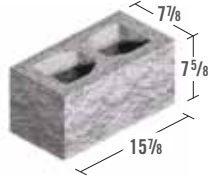

### 170 8" x 8" x 16" RESTRICTED BOND BEAM OPEN BOTTOM SPLIT FACE

8" x 8" x 16"

203 x 203 x 406  
UNIT WEIGHT: 43  
ON PALLET  
90 PER CUBE  
**NON-STOCK**  
SAWCUT

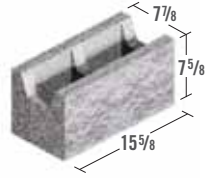

### 170a 8" x 8" x 16" U BOND BEAM SPLIT FACE

8" x 8" x 16"

203 x 203 x 406  
UNIT WEIGHT: 45  
ON PALLET  
90 PER CUBE  
**NON-STOCK**

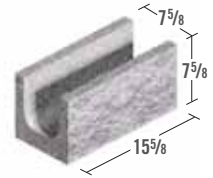

### 173 8" x 8" x 16" TERMITE OR BOND BEAM SPLIT FACE

8" x 8" x 16"

203 x 203 x 406  
UNIT WEIGHT: 63  
ON PALLET  
72 PER CUBE  
**NON-STOCK**

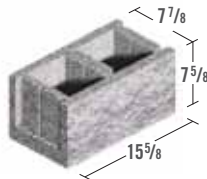

### 174 8" x 8" x 16" TERMITE SPLIT FACE

8" x 8" x 16"

203 x 203 x 406  
UNIT WEIGHT: 54

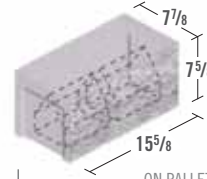

### 175 8" x 8" x 16" TERMITE SASH & END BREAKER SPLIT FACE

8" x 8" x 16"

203 x 203 x 406  
UNIT WEIGHT: 56  
**NON-STOCK**

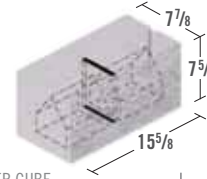

8" x 8" x 16"  
203 x 203 x 406  
UNIT WEIGHT: 56  
**NON-STOCK**

### 175a 8" x 8" x 16" 45 DEGREE HC SPLIT FACE

8" x 8" x 16"

203 x 203 x 406  
UNIT WEIGHT: 53  
ON PALLET  
40 PER CUBE  
**NON-STOCK**

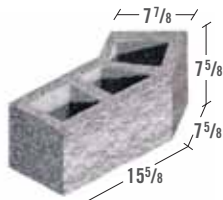

### 175b 8" x 8" x 16" 45 DEGREE HC SINGLE SCORE SPLIT FACE

8" x 8" x 16"

203 x 203 x 406  
UNIT WEIGHT: 53  
ON PALLET  
40 PER CUBE  
**NON-STOCK**

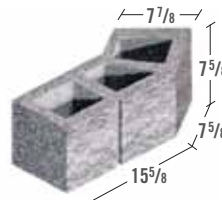

## SPLIT FACE 10"

### 176 10" x 4" x 16" STRETCHER SPLIT FACE

10" x 4" x 16"

254 x 102 x 406  
UNIT WEIGHT: 26  
**NON-STOCK**

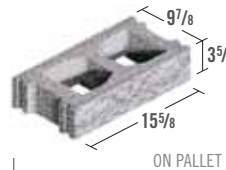

### 177 10" x 4" x 16" SASH & END BREAKER SPLIT FACE

10" x 4" x 16"

254 x 102 x 406  
UNIT WEIGHT: 26  
**NON-STOCK**

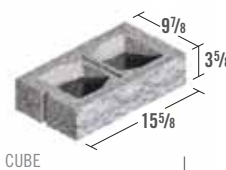

### 178 10" x 8" x 16" STRETCHER SPLIT FACE

10" x 8" x 16"

254 x 203 x 406  
UNIT WEIGHT: 54  
**NON-STOCK**

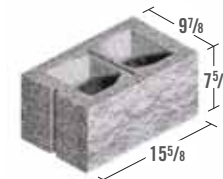
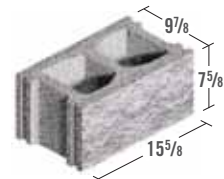
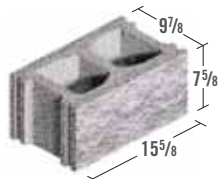
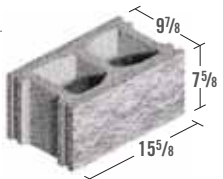

ON PALLET 60 PER CUBE

### 178a 10" x 8" x 16" SASH & END BREAKER SPLIT FACE

10" x 8" x 16"

254 x 203 x 406  
UNIT WEIGHT: 56  
**NON-STOCK**

10" x 8" x 16"  
254 x 203 x 406  
UNIT WEIGHT: 56  
**NON-STOCK**

### 180 10" x 8" x 16" TERMITE OR BOND BEAM SPLIT FACE

10" x 8" x 16"

254 x 203 x 406  
UNIT WEIGHT: 60  
ON PALLET  
60 PER CUBE  
**NON-STOCK**

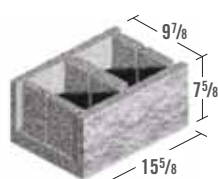

### 181 10" x 8" x 16" OPEN BOTTOM BOND BEAM SPLIT FACE

10" x 8" x 16"

254 x 203 x 406  
UNIT WEIGHT: 53  
ON PALLET  
72 PER CUBE  
**NON-STOCK**

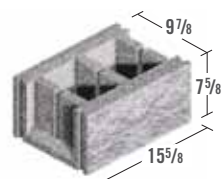





**SPLIT FACE 12"**

**182** 12" x 4" x 16" SOLID SPLIT FACE

12" x 4" x 16"

305 x 102 x 406  
UNIT WEIGHT: 51  
ON PALLET  
60 PER CUBE  
NON-STOCK

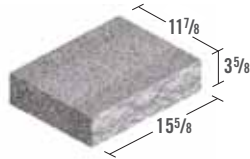

**183** 12" x 4" x 16" DOUBLE END SPLIT FACE

12" x 4" x 16"

305 x 102 x 406  
UNIT WEIGHT: 29  
NON-STOCK

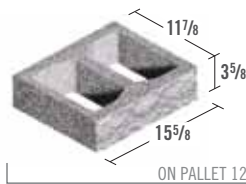

**184** 12" x 4" x 16" SASH & END BREAKER SPLIT FACE

12" x 4" x 16"

305 x 102 x 406  
UNIT WEIGHT: 30  
NON-STOCK

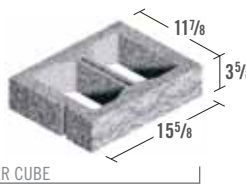

**185** 12" x 8" x 8" SASH & END SPLIT FACE

12" x 8" x 8"

305 x 203 x 203  
UNIT WEIGHT: 31  
ON PALLET  
120 PER CUBE  
NON-STOCK

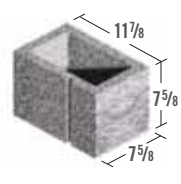

**186** 12" x 8" x 16" STRETCHER SPLIT FACE

12" x 8" x 16"

305 x 203 x 406  
UNIT WEIGHT: 58

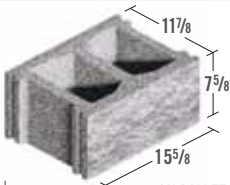

**187** 12" x 8" x 16" SASH & END BREAKER SPLIT FACE

12" x 8" x 16"

305 x 203 x 406  
UNIT WEIGHT: 60  
NON-STOCK

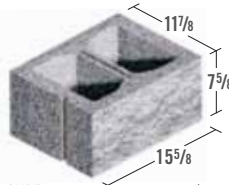

**188** 12" x 8" x 16" TERMITE OR BOND BEAM SPLIT FACE

12" x 8" x 16"

305 x 203 x 406  
UNIT WEIGHT: 63  
ON PALLET  
60 PER CUBE  
NON-STOCK

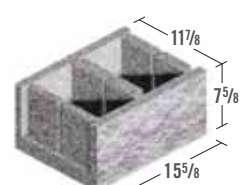

**188a** 12" x 8" x 16" W BOND BEAM SPLIT FACE

12" x 8" x 16"

305 x 203 x 406  
UNIT WEIGHT: 63  
ON PALLET  
60 PER CUBE  
NON-STOCK

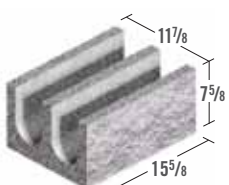

**188b** 12" x 8" x 16" REST. BOND BEAM SPLIT FACE

12" x 8" x 16"

305 x 203 x 406  
UNIT WEIGHT: 63  
ON PALLET  
60 PER CUBE  
NON-STOCK

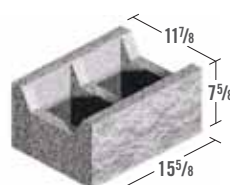

**SCORED SPLIT FACE**

**189** 4" x 8" x 12" SOLID CORNER & END SINGLE SCORE SPLIT FACE

4" x 8" x 12"

102 x 203 x 305  
UNIT WEIGHT: 25  
ON PALLET  
168 PER CUBE  
NON-STOCK

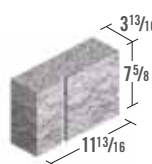

**190** 4" x 8" x 16" SOLID SINGLE SCORE SPLIT FACE FROGGED

4" x 8" x 16"

102 x 203 x 406  
UNIT WEIGHT: 34  
ON PALLET  
108 PER CUBE  
NON-STOCK

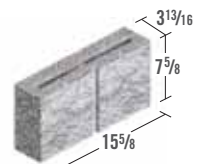

**191** 8" x 4" x 16" DOUBLE END SINGLE SCORE SPLIT FACE

8" x 4" x 16"

203 x 102 x 406  
UNIT WEIGHT: 19  
NON-STOCK

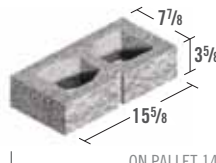

**192** 8" x 4" x 16" SASH & END BREAKER SINGLE SCORE SPLIT FACE

8" x 4" x 16"

203 x 102 x 406  
UNIT WEIGHT: 20  
NON-STOCK

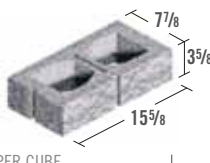

**193** 8" x 4" x 16" CORNER & END SINGLE SCORE SPLIT FACE

8" x 4" x 16"

203 x 102 x 406  
UNIT WEIGHT: 19  
ON PALLET  
120 PER CUBE  
NON-STOCK

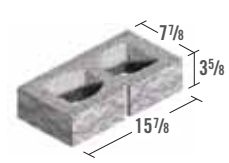



194a

8" x 8" x 16" DOUBLE END SINGLE SCORE SPLIT FACE

8" x 8" x 16"  
203 x 203 x 406  
UNIT WEIGHT: 42  
NON-STOCK

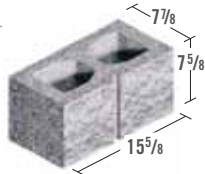

194b

8" x 8" x 16" SASH & END SINGLE SCORE SPLIT FACE

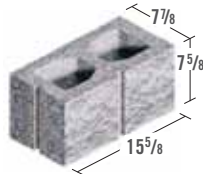

194c

8" x 8" x 16" DOUBLE SASH SINGLE SCORE BREAKER SPLIT FACE

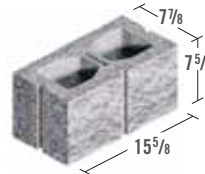

194d

8" x 8" x 16" DOUBLE END BREAKER SINGLE SCORE SPLIT FACE

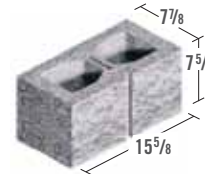

ON PALLET 90 PER CUBE

196

8" x 8" x 16" CORNER & END SINGLE SCORE SPLIT FACE

8" x 8" x 16"  
203 x 203 x 406  
UNIT WEIGHT: 45  
ON PALLET  
90 PER CUBE  
NON-STOCK

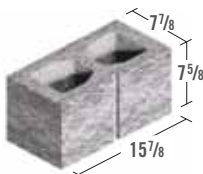

197

12" x 4" x 16" DOUBLE END SINGLE SCORE SPLIT FACE

12" x 4" x 16"  
305 x 102 x 406  
UNIT WEIGHT: 29  
NON-STOCK

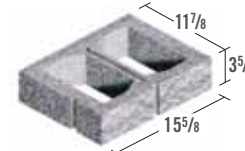
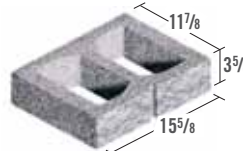

12" x 4" x 16"  
305 x 102 x 406  
UNIT WEIGHT: 30  
NON-STOCK

ON PALLET 120 PER CUBE

199

12" x 8" x 16" STRETCHER SINGLE SCORE SPLIT FACE

12" x 8" x 16"  
305 x 203 x 406  
UNIT WEIGHT: 58  
NON-STOCK

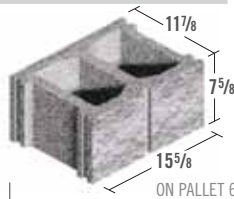

ON PALLET 60 PER CUBE

200

12" x 8" x 16" SASH & END BREAKER SINGLE SCORE SPLIT FACE

12" x 8" x 16"  
305 x 203 x 406  
UNIT WEIGHT: 60  
NON-STOCK

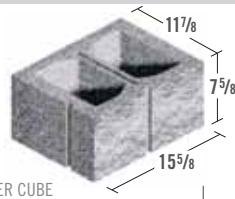

12" x 8" x 16"  
305 x 203 x 406  
UNIT WEIGHT: 60  
NON-STOCK

**3 FLUTE SPLIT FACE**

213

4" x 8" x 16" SOLID DOUBLE END 3 FLUTE SPLIT FACE

4" x 8" x 16"  
102 x 203 x 406  
UNIT WEIGHT: 29  
ON PALLET  
144 PER CUBE  
NON-STOCK

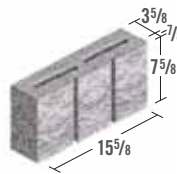

214

8" x 8" x 16" STRETCHER 3 FLUTE SPLIT FACE

8" x 8" x 16"  
203 x 203 x 406  
UNIT WEIGHT: 43  
NON-STOCK

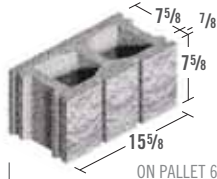

ON PALLET 60 PER CUBE

215

8" x 8" x 16" SASH & END BREAKER 3 FLUTE SPLIT FACE

8" x 8" x 16"  
203 x 203 x 406  
UNIT WEIGHT: 44  
NON-STOCK

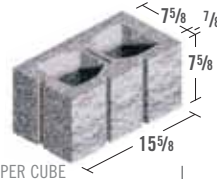

8" x 8" x 16"  
203 x 203 x 406  
UNIT WEIGHT: 44  
NON-STOCK

216

8" x 8" x 16" 45 DEGREE CORNER & END 3 FLUTE SPLIT FACE

8" x 8" x 16"  
203 x 203 x 406  
UNIT WEIGHT: 44  
ON PALLET  
60 PER CUBE  
NON-STOCK

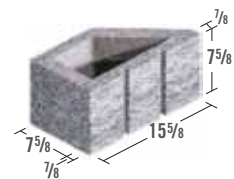

217

12" x 8" x 16" STRETCHER 3 FLUTE SPLIT FACE

12" x 8" x 16"  
305 x 203 x 406  
UNIT WEIGHT: 58  
NON-STOCK

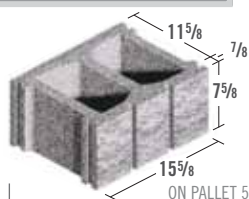

ON PALLET 54 PER CUBE

218

12" x 8" x 16" SASH & END BREAKER 3 FLUTE SPLIT FACE

12" x 8" x 16"  
305 x 203 x 406  
UNIT WEIGHT: 59  
NON-STOCK

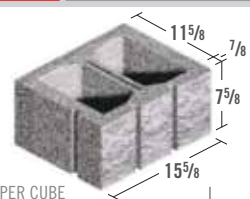

12" x 8" x 16"  
305 x 203 x 406  
UNIT WEIGHT: 59  
NON-STOCK



## DEEP 4 FLUTE SPLIT FACE

**219** 4" x 8" x 12" SOLID CORNER & END DEEP  
4 FLUTE SPLIT FACE

4" x 8" x 12"  
102 x 203 x 305  
UNIT WEIGHT: 24  
ON PALLET  
96 PER CUBE  
NON-STOCK

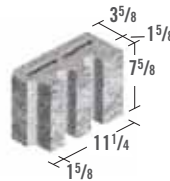

**220** 4" x 8" x 16" SOLID DOUBLE END DEEP  
4 FLUTE SPLIT FACE

4" x 8" x 16"  
102 x 203 x 406  
UNIT WEIGHT: 30  
ON PALLET  
108 PER CUBE  
NON-STOCK

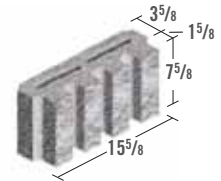

**221** 8" x 8" x 16" STRETCHER DEEP  
4 FLUTE SPLIT FACE

8" x 8" x 16"  
203 x 203 x 406  
UNIT WEIGHT: 55  
NON-STOCK

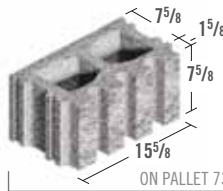

**222** 8" x 8" x 16" SASH & END BREAKER DEEP  
4 FLUTE SPLIT FACE

8" x 8" x 16"  
203 x 203 x 406  
UNIT WEIGHT: 56  
NON-STOCK

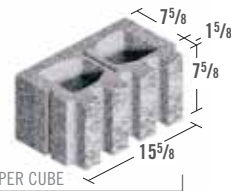

**223** 10" x 8" x 16" STRETCHER DEEP  
4 FLUTE SPLIT FACE

10" x 8" x 16"  
254 x 203 x 406  
UNIT WEIGHT: 55  
NON-STOCK

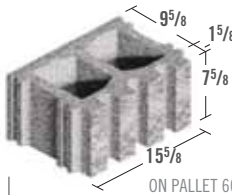

**224** 10" x 8" x 16" SASH & END BREAKER  
DEEP 4 FLUTE SPLIT FACE

10" x 8" x 16"  
254 x 203 x 406  
UNIT WEIGHT: 56  
NON-STOCK

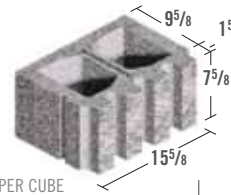

**225** 12" x 8" x 16" STRETCHER DEEP  
4 FLUTE SPLIT FACE

12" x 8" x 16"  
305 x 203 x 406  
UNIT WEIGHT: 62  
ON PALLET  
55 PER CUBE  
NON-STOCK

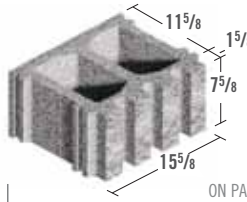

**SPECIAL NOTE: WHEN YOU PURCHASE 225 YOU MUST ALSO PURCHASE 221 IN EQUAL AMOUNTS BECAUSE WHEN WE MANUFACTURE A 12" DEEP 4 FLUTE, AN 8" DEEP 4 FLUTE IS MADE IN CONJUNCTION**

## WIDE 4 FLUTE SPLIT FACE

**226** 4" x 8" x 16" SOLID DOUBLE END WIDE  
4 FLUTE SPLIT FACE

4" x 8" x 16"  
102 x 203 x 406  
UNIT WEIGHT: 30  
ON PALLET  
144 PER CUBE  
NON-STOCK

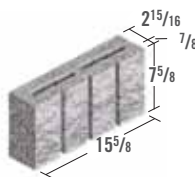

**227** 4" x 8" x 16" SOLID 45 DEGREE CORNER &  
END WIDE 4 FLUTE SPLIT FACE

4" x 8" x 16"  
102 x 203 x 406  
UNIT WEIGHT: 26  
ON PALLET  
144 PER CUBE  
NON-STOCK

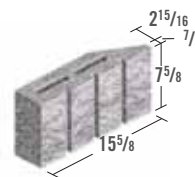

**228** 8" x 8" x 16" 45 DEGREE CORNER &  
END WIDE 4 FLUTE SPLIT FACE

8" x 8" x 16"  
203 x 203 x 406  
UNIT WEIGHT: 45  
ON PALLET  
75 PER CUBE  
NON-STOCK

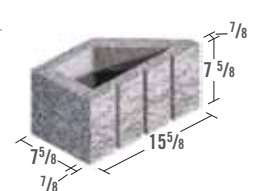

**229** 8" x 8" x 16" STRETCHER WIDE 4 FLUTE  
SPLIT FACE

8" x 8" x 16"  
203 x 203 x 406  
UNIT WEIGHT: 43  
NON-STOCK

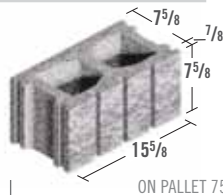

**230** 8" x 8" x 16" SASH & END BREAKER WIDE  
4 FLUTE SPLIT FACE

8" x 8" x 16"  
203 x 203 x 406  
UNIT WEIGHT: 44  
NON-STOCK

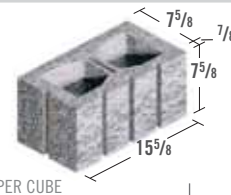



**231** 12" x 8" x 16" STRETCHER WIDE  
4 FLUTE SPLIT FACE

12" x 8" x 16"  
305 x 203 x 406  
UNIT WEIGHT: 57  
NON-STOCK

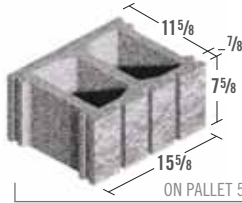

**232** 12" x 8" x 16" SASH & END BREAKER WIDE  
4 FLUTE SPLIT FACE

12" x 8" x 16"  
305 x 203 x 406  
UNIT WEIGHT: 58  
NON-STOCK

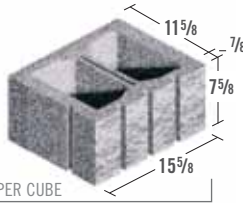

ON PALLET 54 PER CUBE

**6 FLUTE SPLIT FACE**

**233** 4" x 8" x 16" SOLID DOUBLE END 6 FLUTE  
SPLIT FACE

4" x 8" x 16"  
102 x 203 x 406  
UNIT WEIGHT: 29  
ON PALLET  
144 PER CUBE  
NON-STOCK

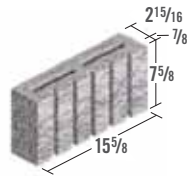

**234** 4" x 8" x 16" SOLID 45 DEGREE CORNER &  
END 6 FLUTE SPLIT FACE

4" x 8" x 16"  
102 x 203 x 406  
UNIT WEIGHT: 26  
ON PALLET  
144 PER CUBE  
NON-STOCK

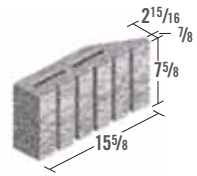

**235** 8" x 8" x 16" 45 DEGREE CORNER & END  
6 FLUTE SPLIT FACE

8" x 8" x 16"  
203 x 203 x 406  
UNIT WEIGHT: 43  
ON PALLET  
75 PER CUBE  
NON-STOCK

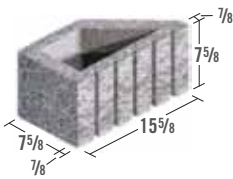

**236** 8" x 8" x 16" STRETCHER 6 FLUTE  
SPLIT FACE

8" x 8" x 16"  
203 x 203 x 406  
UNIT WEIGHT: 43  
NON-STOCK

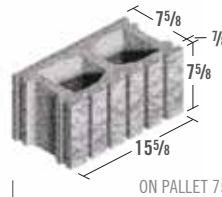

**237** 8" x 8" x 16" SASH & END BREAKER  
6 FLUTE SPLIT FACE

8" x 8" x 16"  
203 x 203 x 406  
UNIT WEIGHT: 44  
NON-STOCK

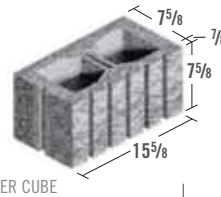

ON PALLET 75 PER CUBE

**238** 12" x 8" x 16" STRETCHER 6 FLUTE SPLIT FACE

12" x 8" x 16"  
305 x 203 x 406  
UNIT WEIGHT: 58  
NON-STOCK

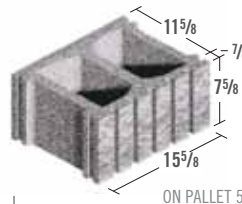

**239** 12" x 8" x 16" SASH & END BREAKER  
6 FLUTE SPLIT FACE

12" x 8" x 16"  
305 x 203 x 406  
UNIT WEIGHT: 59  
NON-STOCK

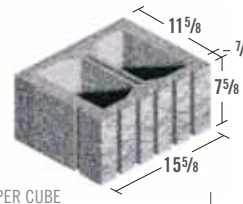

ON PALLET 54 PER CUBE

**8 FLUTE SPLIT FACE**

**240** 4" x 8" x 16" SOLID DOUBLE END 8 FLUTE  
SPLIT FACE

4" x 8" x 16"  
102 x 203 x 406  
UNIT WEIGHT: 30  
ON PALLET  
144 PER CUBE  
NON-STOCK

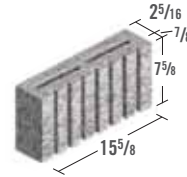

**241** 4" x 8" x 16" SOLID 45 DEGREE CORNER &  
END 8 FLUTE SPLIT FACE

4" x 8" x 16"  
102 x 203 x 406  
UNIT WEIGHT: 26  
ON PALLET  
144 PER CUBE  
NON-STOCK

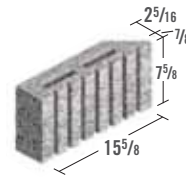

**242** 8" x 8" x 16" 45 DEGREE CORNER & END  
8 FLUTE SPLIT FACE

8" x 8" x 16"  
203 x 203 x 406  
UNIT WEIGHT: 40  
ON PALLET  
75 PER CUBE  
NON-STOCK

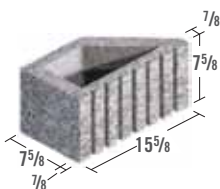

**243** 8" x 8" x 16" STRETCHER 8 FLUTE SPLIT FACE

8" x 8" x 16"  
203 x 203 x 406  
UNIT WEIGHT: 43  
NON-STOCK

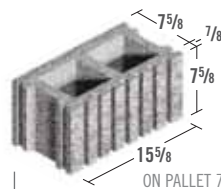

**244** 8" x 8" x 16" SASH & END BREAKER  
8 FLUTE SPLIT FACE

8" x 8" x 16"  
203 x 203 x 406  
UNIT WEIGHT: 44  
NON-STOCK

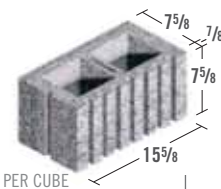

ON PALLET 75 PER CUBE



245

12" x 8" x 16"

305 x 203 x 406  
UNIT WEIGHT: 61  
NON-STOCK

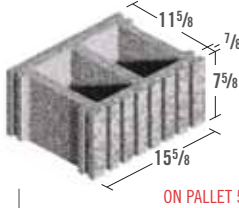

246

12" x 8" x 16" SASH & END BREAKER  
8 FLUTE SPLIT FACE

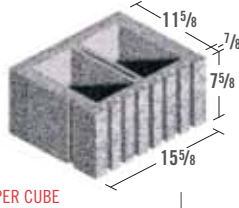

12" x 8" x 16"

305 x 203 x 406  
UNIT WEIGHT: 62  
NON-STOCK

ON PALLET 54 PER CUBE

**SOLID CHAMFERED SILLS**

261

4" x 8" x 16" SOLID CHAMFERED SILL

4" x 8" x 16"

102 x 203 x 406  
UNIT WEIGHT: 28  
ON PALLET  
108 PER CUBE  
NON-STOCK

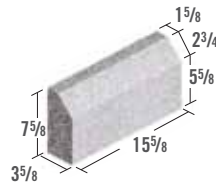

263

6" x 8" x 16" SOLID CHAMFERED SILL

6" x 8" x 16"

152 x 203 x 406  
UNIT WEIGHT: 47  
ON PALLET  
72 PER CUBE  
NON-STOCK

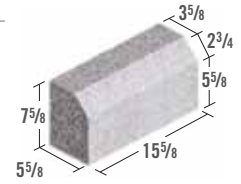

264

8" x 8" x 16" SOLID CHAMFERED SILL

8" x 8" x 16"

203 x 203 x 406  
UNIT WEIGHT: 64  
ON PALLET  
54 PER CUBE  
NON-STOCK

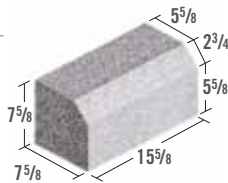

266

4" x 8" x 16" SOLID CHAMFERED SILL  
SPLIT FACE

4" x 8" x 16"

102 x 203 x 406  
UNIT WEIGHT: 29  
ON PALLET  
108 PER CUBE  
NON-STOCK



268

6" x 8" x 16" SOLID CHAMFERED SILL  
SPLIT FACE

6" x 8" x 16"

152 x 203 x 406  
UNIT WEIGHT: 48  
ON PALLET  
72 PER CUBE  
NON-STOCK

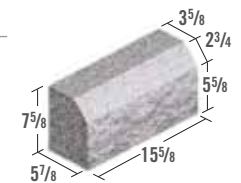

269

8" x 8" x 16" SOLID CHAMFERED SILL  
SPLIT FACE

8" x 8" x 16"

203 x 203 x 406  
UNIT WEIGHT: 66  
ON PALLET  
54 PER CUBE  
NON-STOCK

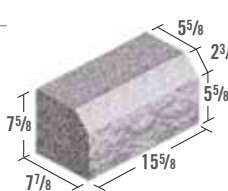

**COLOSSALBLOK™**

270

4" x 12" x 16" SOLID

4" x 12" x 16"

102 x 305 x 406  
UNIT WEIGHT: 50  
ON PALLET  
72 PER CUBE  
NON-STOCK

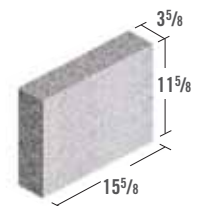

272

4" x 8" x 24" SOLID

4" x 8" x 24"

102 x 203 x 610  
UNIT WEIGHT: 50  
ON PALLET  
72 PER CUBE  
NON-STOCK

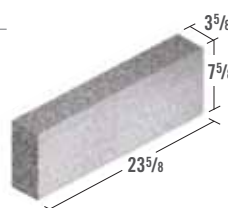

273

4" x 12" x 24" SOLID

4" x 12" x 24"

102 x 305 x 610  
UNIT WEIGHT: 80  
ON PALLET  
48 PER CUBE  
NON-STOCK

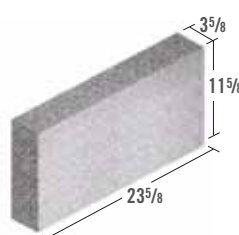



**275** 4" x 12" x 16" SOLID SPLIT FACE

4" x 12" x 16"  
102 x 305 x 406  
UNIT WEIGHT: 53  
ON PALLET  
72 PER CUBE  
NON-STOCK

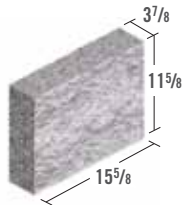

**277** 4" x 8" x 24" SOLID SPLIT FACE

4" x 8" x 24"  
102 x 203 x 610  
UNIT WEIGHT: 53  
ON PALLET  
72 PER CUBE  
NON-STOCK

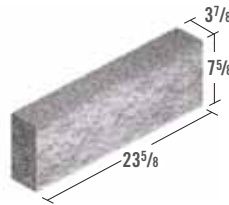

**278** 4" x 12" x 24" SOLID SPLIT FACE

4" x 12" x 24"  
102 x 305 x 610  
UNIT WEIGHT: 83  
ON PALLET  
48 PER CUBE  
NON-STOCK

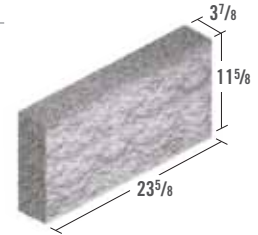

**SOUNDBLOX®**

**280** 4" x 8" x 16" TYPE RSC (4") SOUNDBLOX

4" x 8" x 16"  
102 x 203 x 406  
UNIT WEIGHT: 24  
ON PALLET  
144 PER CUBE  
NON-STOCK

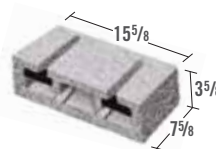

**281** 6" x 8" x 16" TYPE RSC (6") SOUNDBLOX

6" x 8" x 16"  
152 x 203 x 406  
UNIT WEIGHT: 33  
ON PALLET  
108 PER CUBE  
NON-STOCK



**282** 8" x 8" x 16" TYPE RSC (8") SOUNDBLOX

8" x 8" x 16"  
203 x 203 x 406  
UNIT WEIGHT: 43  
ON PALLET  
90 PER CUBE  
NON-STOCK

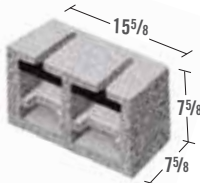

**283** 8" x 8" x 16" TYPE RSC (8") LH SOUNDBLOX

8" x 8" x 16"  
203 x 203 x 406  
UNIT WEIGHT: 43  
ON PALLET  
90 PER CUBE  
NON-STOCK

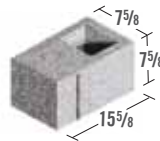

**284** 8" x 8" x 16" TYPE RSC (8") RH SOUNDBLOX

8" x 8" x 16"  
203 x 203 x 406  
UNIT WEIGHT: 43  
ON PALLET  
90 PER CUBE  
NON-STOCK

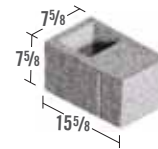

**285** 12" x 8" x 16" TYPE RSC (12") SOUNDBLOX

12" x 8" x 16"  
305 x 203 x 406  
UNIT WEIGHT: 59  
ON PALLET  
60 PER CUBE  
NON-STOCK

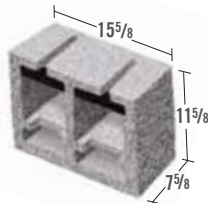

**286** 12" x 8" x 16" TYPE RSC (12") LH SOUNDBLOX

12" x 8" x 16"  
305 x 203 x 406  
UNIT WEIGHT: 59  
ON PALLET  
60 PER CUBE  
NON-STOCK

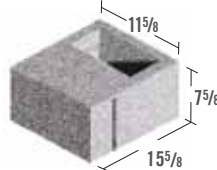

**287** 12" x 8" x 16" TYPE RSC (12") RH SOUNDBLOX

12" x 8" x 16"  
305 x 203 x 406  
UNIT WEIGHT: 59  
ON PALLET  
60 PER CUBE  
NON-STOCK

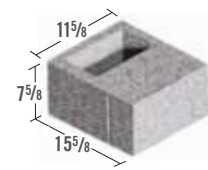

**288** 8" x 8" x 16" TYPE RSC/RF (8") SOUNDBLOX

8" x 8" x 16"  
203 x 203 x 406  
UNIT WEIGHT: 43  
ON PALLET  
90 PER CUBE  
NON-STOCK

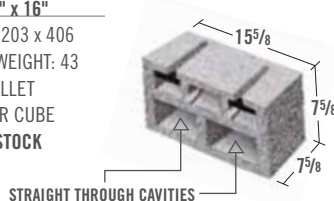

**289** 10" x 8" x 16" TYPE RSC/RF (10") SOUNDBLOX

10" x 8" x 16"  
254 x 203 x 406  
UNIT WEIGHT: 51  
ON PALLET  
72 PER CUBE  
NON-STOCK

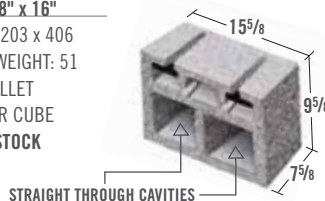

**290** 12" x 8" x 16" TYPE RSC/RF (12") SOUNDBLOX

12" x 8" x 16"  
305 x 203 x 406  
UNIT WEIGHT: 59  
ON PALLET  
60 PER CUBE  
NON-STOCK

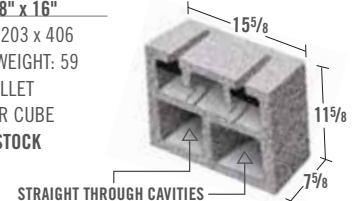



**291** 12" x 8" x 16" TYPE RSC/RF4 (12") SOUNDBLOX

12" x 8" x 16"  
305 x 203 x 406  
UNIT WEIGHT: 59  
ON PALLET  
60 PER CUBE  
NON-STOCK

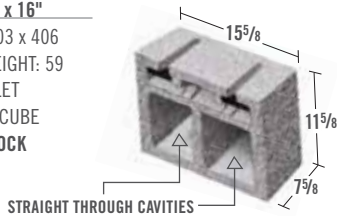

**AZAR MORTARLESS  
DRY-STACK®**

**292** 8" x 8" x 16" AZAR STRETCHER

8" x 8" x 16"  
203 x 203 x 406  
UNIT WEIGHT: 42  
ON PALLET  
90 PER CUBE  
NON-STOCK

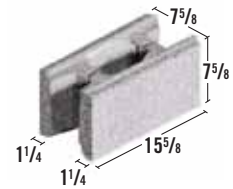

**293** 8" x 8" x 16" AZAR LEFT-HAND CORNER

8" x 8" x 16"  
203 x 203 x 406  
UNIT WEIGHT: 44  
ON PALLET  
45 PER CUBE  
CUBED WITH  
RH CORNER

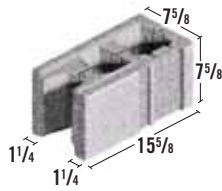

**294** 8" x 8" x 16" AZAR RIGHT-HAND CORNER

8" x 8" x 16"  
203 x 203 x 406  
UNIT WEIGHT: 44  
ON PALLET  
45 PER CUBE  
CUBED WITH  
LH CORNER  
NON-STOCK

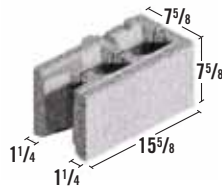

ON PALLET 90 PER CUBE

**295** 8" x 8" x 8" AZAR HALF UNIT

8" x 8" x 8"  
203 x 203 x 203  
UNIT WEIGHT: 25  
ON PALLET  
60 PER CUBE  
CUBED WITH  
FULL END

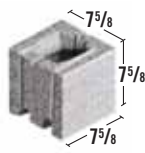

**296** 8" x 8" x 16" AZAR FULL SASH

8" x 8" x 16"  
203 x 203 x 406  
UNIT WEIGHT: 44  
ON PALLET  
60 PER CUBE  
CUBED WITH  
1/2 END  
NON-STOCK

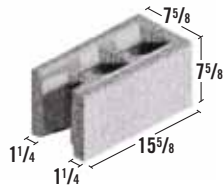

ON PALLET 120 PER CUBE

**Hi R® ENERGY WALL SYSTEM**

**297** 12" x 4" x 16" Hi R SMOOTH\*

12" x 4" x 16"  
305 x 102 x 406  
UNIT WEIGHT: 22  
ON PALLET  
120 PER CUBE  
NON-STOCK

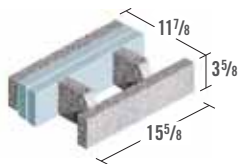

**298** 12" x 4" x 16" Hi R SPLIT FACE\*

12" x 4" x 16"  
305 x 102 x 406  
UNIT WEIGHT: 23  
ON PALLET  
120 PER CUBE  
NON-STOCK

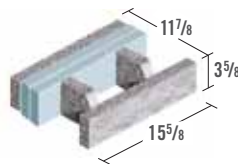

**299** 12" x 8" x 16" Hi R SMOOTH\*

12" x 8" x 16"  
305 x 203 x 406  
UNIT WEIGHT: 43  
ON PALLET  
60 PER CUBE  
NON-STOCK

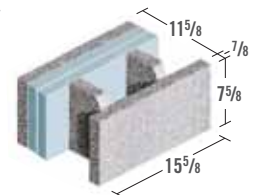

**300** 12" x 8" x 16" Hi R SPLIT FACE\*

12" x 8" x 16"  
305 x 102 x 406  
UNIT WEIGHT: 44  
ON PALLET  
60 PER CUBE  
NON-STOCK

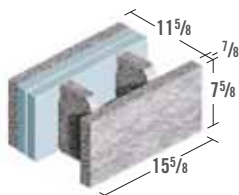



**ARTISTRY SERIES**

**303** 4" x 8" x 16" SOLID TUMBLED FROGGED

4" x 8" x 16"  
102 x 203 x 406  
UNIT WEIGHT: 34  
ON PALLET  
NON-STOCK

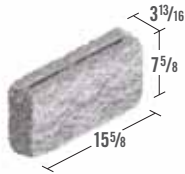

**301** 4" x 4" x 16" SOLID TUMBLED FROGGED

4" x 4" x 16"  
102 x 102 x 406  
UNIT WEIGHT: 17  
ON PALLET  
NON-STOCK



**302** 4" x 8" x 8" SOLID TUMBLED

4" x 8" x 8"  
102 x 203 x 203  
UNIT WEIGHT: 17  
ON PALLET  
NON-STOCK

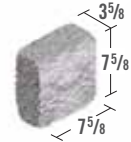

**NOTES:**

Lined area for notes with 18 horizontal lines.





**CORNER DETAILS** ▽

**A** 4" WALL USING 4" x 8" x 12" SOLID CORNER & END SPLIT FACE

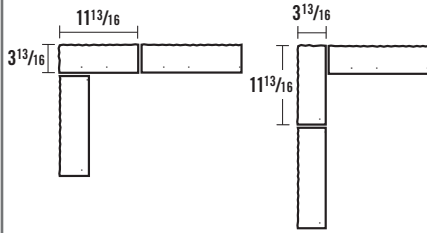

1st COURSE 2nd COURSE

**B** 4" WALL USING 4" x 8" x 16" FULL RETURN L CORNER

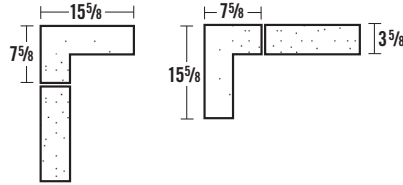

1st COURSE 2nd COURSE

**Ba** 4" WALL USING 4" x 8" x 16" FULL RETURN L CORNER SPLIT FACE

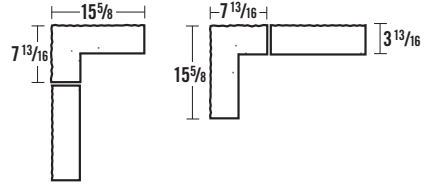

1st COURSE 2nd COURSE

**C** 4" WALL USING 4" x 8" x 12" CORNER & END DEEP 4 FLUTE SPLIT FACE

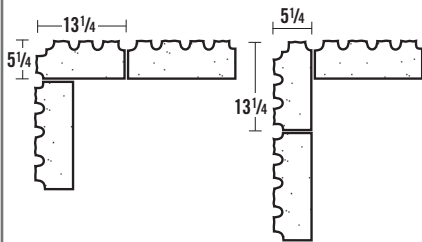

1st COURSE 2nd COURSE

**D** 4" WALL USING 4" x 8" x 16" 45° CORNER & END 8 FLUTE SPLIT FACE

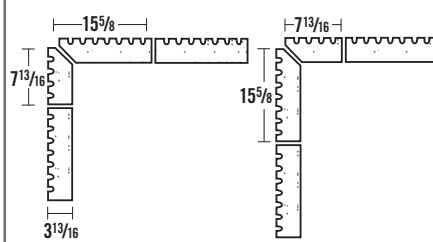

1st COURSE 2nd COURSE

**E** 6" WALL USING 6" x 8" x 14" DOUBLE END

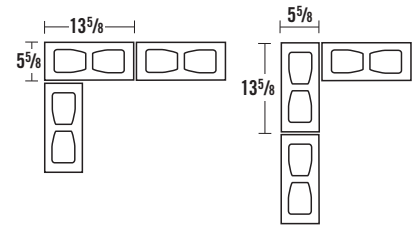

1st COURSE 2nd COURSE

**F** 8" WALL USING 4" x 8" x 12" SOLID CORNER & END SPLIT FACE

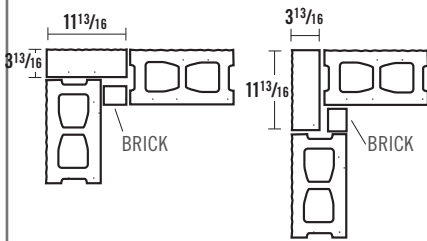

1st COURSE 2nd COURSE

**G** 8" WALL USING 8" x 8" x 16" CORNER & END SPLIT FACE

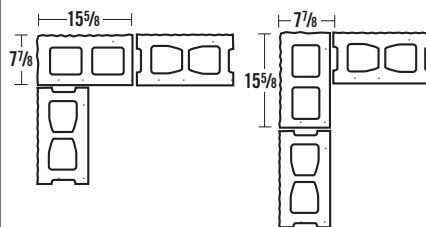

1st COURSE 2nd COURSE

**I** 8" WALL USING 4" x 8" x 12" CORNER & END DEEP 4 FLUTE SPLIT FACE

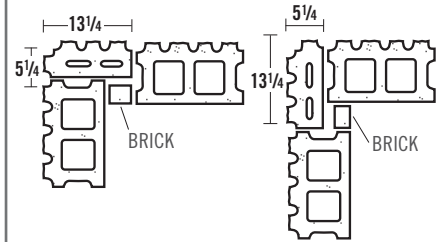

1st COURSE 2nd COURSE

**J** 8" WALL USING 8" x 8" x 16" 45° CORNER & END 8 FLUTE SPLIT FACE

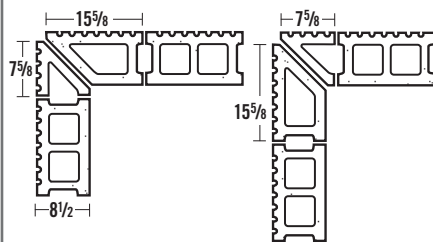

1st COURSE 2nd COURSE

**K** 10" WALL USING 10" x 8" x 16" RETURN CORNER

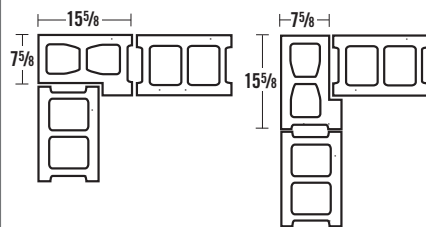

1st COURSE 2nd COURSE

**L** 12" WALL USING 4" x 8" x 12" SOLID CORNER SPLIT FACE

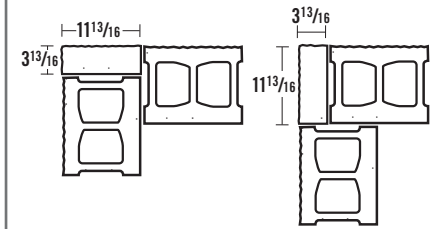

1st COURSE 2nd COURSE



**CORNER DETAILS (CONTINUED)** ▾

<p><b>M</b> 12" WALL USING 8" x 8" x 16" CORNER &amp; END SPLIT FACE</p> <p>1st COURSE      2nd COURSE</p>	<p><b>N</b> 12" WALL USING 4" x 8" x 12" CORNER &amp; END DEEP 4 FLUTE SPLIT FACE</p> <p>1st COURSE      2nd COURSE</p>	<p><b>O</b> 12" WALL USING 12" x 8" x 16" RETURN CORNER</p> <p>1st COURSE      2nd COURSE</p>
<p><b>P</b> 14" WALL USING 6" x 8" x 14" DOUBLE END</p> <p>1st COURSE      2nd COURSE</p>	<p><b>Q</b> 16" WALL USING 8" x 8" x 16" DOUBLE END</p> <p>1st COURSE      2nd COURSE</p>	<p><b>R</b> 4" WALL USING 4" x 12" x 16" SOLID CORNER &amp; END SPLIT FACE OR SAND BLASTED</p> <p>1st COURSE      2nd COURSE</p>

**PIER DETAILS** ▾

<p><b>8" UNITS</b></p>	
<p>1st COURSE</p>	<p>2nd COURSE</p>
<p><b>8" &amp; 12" UNITS</b></p>	
<p>1st COURSE</p>	<p>2nd COURSE</p>



**LENGTH OF CONCRETE MASONRY WALLS BY STRETCHERS** ▾

NO. OF STRETCHERS	WALL LENGTH
1	1'4"
1.5	2'0"
2	2'8"
2.5	3'4"
3	4'0"
3.5	4'8"
4	5'4"
4.5	6'0"
5	6'8"
5.5	7'4"
6	8'0"
6.5	8'8"
7	9'4"
7.5	10'0"
8	10'8"
8.5	11'4"
9	12'0"
9.5	12'8"
10	13'4"
10.5	14'0"
11	14'8"
11.5	15'4"
12	16'0"
12.5	16'8"
13	17'4"
13.5	18'0"
14	18'8"
14.5	19'4"
15	20'0"
20	26'8"



**HEIGHT OF CONCRETE MASONRY WALLS BY COURSES** ▾

NO. OF COURSES	WALL HEIGHT					
	3/8" BED JOINT		7/16" BED JOINT		1/2" BED JOINT	
	8" BLOCK	4" BLOCK	8" block	4" block	8" block	4" block
1	8"	4"	8 <sup>1</sup> / <sub>16</sub> "	4 <sup>1</sup> / <sub>16</sub> "	8 <sup>1</sup> / <sub>8</sub> "	4 <sup>1</sup> / <sub>8</sub> "
2	1'4"	8"	1'4 <sup>1</sup> / <sub>8</sub> "	8 <sup>1</sup> / <sub>8</sub> "	1'4 <sup>1</sup> / <sub>4</sub> "	8 <sup>1</sup> / <sub>4</sub> "
3	2'0"	1'0"	2' <sup>13</sup> / <sub>16</sub> "	1' <sup>3</sup> / <sub>16</sub> "	2' <sup>3</sup> / <sub>8</sub> "	1' <sup>3</sup> / <sub>8</sub> "
4	2'8"	1'4"	2'8 <sup>1</sup> / <sub>4</sub> "	1'4 <sup>1</sup> / <sub>4</sub> "	2'8 <sup>1</sup> / <sub>2</sub> "	1'4 <sup>1</sup> / <sub>2</sub> "
5	3'4"	1'8"	3'4 <sup>5</sup> / <sub>16</sub> "	1'8 <sup>5</sup> / <sub>16</sub> "	3'4 <sup>5</sup> / <sub>8</sub> "	1'8 <sup>5</sup> / <sub>8</sub> "
6	4'0"	2'0"	4' <sup>3</sup> / <sub>8</sub> "	2' <sup>3</sup> / <sub>8</sub> "	4' <sup>3</sup> / <sub>4</sub> "	2' <sup>3</sup> / <sub>4</sub> "
7	4'8"	2'4"	4'8 <sup>7</sup> / <sub>16</sub> "	2'4 <sup>7</sup> / <sub>16</sub> "	4'8 <sup>7</sup> / <sub>8</sub> "	2'4 <sup>7</sup> / <sub>8</sub> "
8	5'4"	2'8"	5'4 <sup>1</sup> / <sub>2</sub> "	2'8 <sup>1</sup> / <sub>2</sub> "	5'5"	2'9"
9	6'0"	3'0"	6' <sup>9</sup> / <sub>16</sub> "	3' <sup>9</sup> / <sub>16</sub> "	6'1 <sup>1</sup> / <sub>8</sub> "	3'1 <sup>1</sup> / <sub>8</sub> "
10	6'8"	3'4"	6'8 <sup>5</sup> / <sub>8</sub> "	3'4 <sup>5</sup> / <sub>8</sub> "	6'9 <sup>1</sup> / <sub>4</sub> "	3'5 <sup>1</sup> / <sub>4</sub> "
15	10'0"	5'0"	10' <sup>15</sup> / <sub>16</sub> "	5' <sup>15</sup> / <sub>16</sub> "	10'1 <sup>7</sup> / <sub>8</sub> "	5'1 <sup>7</sup> / <sub>8</sub> "
20	13'4"	6'8"	13'5 <sup>1</sup> / <sub>4</sub> "	6'9 <sup>1</sup> / <sub>4</sub> "	13'6 <sup>1</sup> / <sub>2</sub> "	6'10 <sup>1</sup> / <sub>2</sub> "
25	16'8"	8'4"	16'9 <sup>9</sup> / <sub>16</sub> "	8'5 <sup>9</sup> / <sub>16</sub> "	16'11 <sup>1</sup> / <sub>8</sub> "	8'7 <sup>1</sup> / <sub>8</sub> "
30	20'0"	10'0"	20'1 <sup>7</sup> / <sub>8</sub> "	10'1 <sup>7</sup> / <sub>8</sub> "	20'3 <sup>3</sup> / <sub>4</sub> "	10'3 <sup>3</sup> / <sub>4</sub> "
35	23'4"	11'8"	23'6 <sup>3</sup> / <sub>16</sub> "	11'10 <sup>3</sup> / <sub>16</sub> "	23'8 <sup>3</sup> / <sub>8</sub> "	12' <sup>3</sup> / <sub>8</sub> "
40	26'8"	13'4"	26'10 <sup>1</sup> / <sub>2</sub> "	13'6 <sup>1</sup> / <sub>2</sub> "	27'1"	13'9"
45	30'0"	15'0"	30'2 <sup>13</sup> / <sub>16</sub> "	15'2 <sup>13</sup> / <sub>16</sub> "	30'5 <sup>5</sup> / <sub>8</sub> "	15'5 <sup>5</sup> / <sub>8</sub> "
50	33'4"	16'8"	33'7 <sup>1</sup> / <sub>8</sub> "	16'11 <sup>1</sup> / <sub>8</sub> "	33'10 <sup>1</sup> / <sub>4</sub> "	17'2 <sup>1</sup> / <sub>4</sub> "

\* Based on concrete blocks 15<sup>5</sup>/<sub>8</sub> in. long and half units 7<sup>5</sup>/<sub>8</sub> in. long, with <sup>3</sup>/<sub>8</sub> in. thick head joints. Actual lengths of finished walls are <sup>3</sup>/<sub>8</sub> in. less than the modular dimensions shown in this table.



**ESTIMATING GUIDES** ▽ The figures shown below are intended for “rule of thumb” use only

**UNIT QUANTITIES**

Standard Block (8x8x16)

1.13 block per square foot of wall area

Concrete Brick

7.0 concrete brick per square foot of wall area

Half-High Block (4x4x16 or 8x4x16)

2.26 block per square foot of wall area

**MORTAR QUANTITIES**

Per 1000 Units	Masonry Cement Bags	Sand Tons
4" and 6" Regular Block	20	2
8", 10", and 12" Regular Block	25	2½
Concrete Brick	8	1¼

**APPROXIMATE VOLUME REQUIRED TO FILL CORE VOIDS IN BLOCK**

6 x 8 x 16	2 core	0.17 cu.ft./block
6 x 8 x 16	3 core	0.15 cu.ft./block
8 x 8 x 16	2 core	0.25 cu.ft./block
8 x 8 x 16	3 core	0.22 cu.ft./block
10 x 8 x 16	2 core	0.33 cu.ft./block
10 x 8 x 16	3 core	0.29 cu.ft./block
12 x 8 x 16	2 core	0.39 cu.ft./block
12 x 8 x 16	3 core	0.34 cu.ft./block

Example: 5000 - 8" - 2 core H.C. to be filled  
 $5000 \times 0.25 = 1250 \text{ cu. ft.} \div 27 \text{ cu. ft. per yard}$   
 $= 46.30 \text{ yards}$

**APPROXIMATE QUANTITIES OF CONCRETE REQUIRED TO FILL LINTELS AND BOND BEAMS** ▽

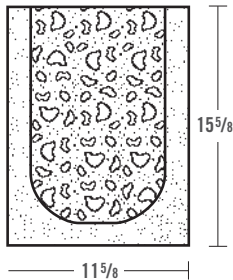

.74 cu.ft. concrete per lin. ft.

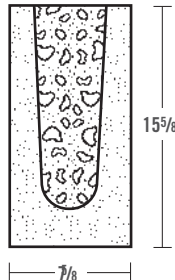

.46 cu.ft. concrete per lin. ft.

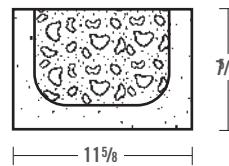

.37 cu.ft. concrete per lin. ft.

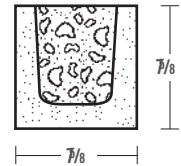

.22 cu.ft. concrete per lin. ft.

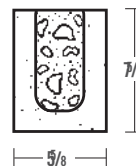

.173 cu.ft. concrete per lin. ft.

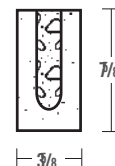

.08 cu.ft. concrete per lin. ft.

**DESIGNSTONE AUTO CAD DRAWINGS** ▾

**C-1**

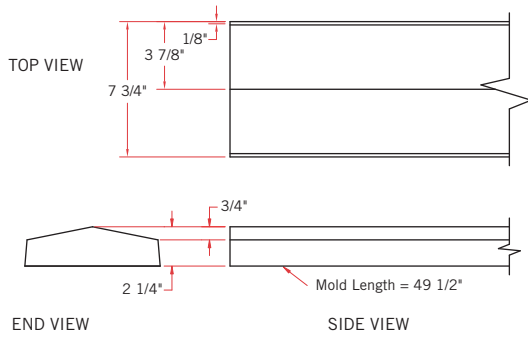

DESCRIPTION: Coping		
DATE:	Sept. 1, 2011	DRAWING NUMBER: <b>C-1</b>
DRAWN BY:	Lew Wood	
SCALE:	3/16"=1"	
NUMBER of MOLDS:	1	

**C-3**

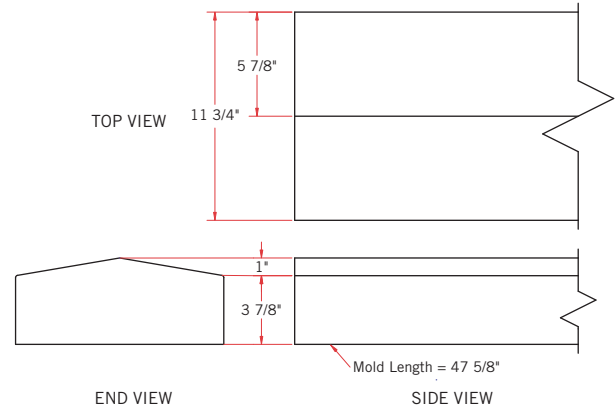

DESCRIPTION: Coping		
DATE:	Sept. 1, 2011	DRAWING NUMBER: <b>C-3</b>
DRAWN BY:	Lew Wood	
SCALE:	3/16"=1"	
NUMBER of MOLDS:	3	

**C-12**

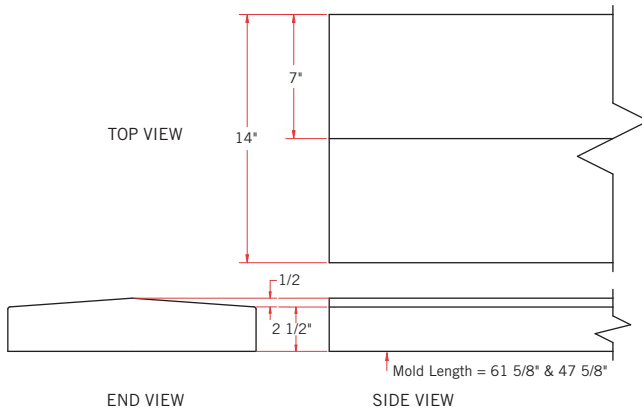

DESCRIPTION: Coping		2 special corner molds available. 3 molds are 47 5/8" in length 2 molds are 61 5/8" in length
DATE:	Sept. 1, 2011	DRAWING NUMBER: <b>C-12</b>
DRAWN BY:	Lew Wood	
SCALE:	3/16"=1"	
NUMBER of MOLDS:	5	

**C-19**

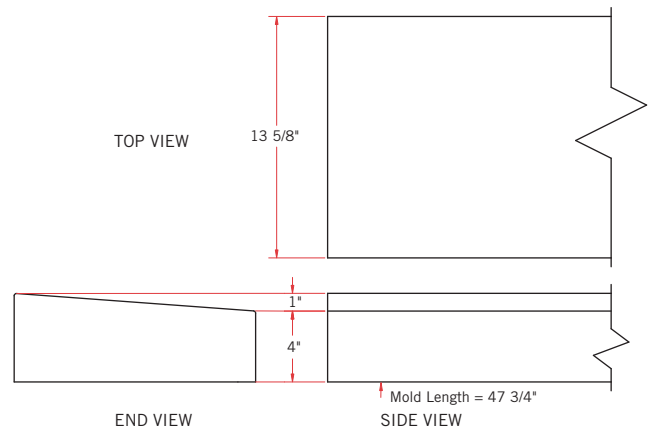

DESCRIPTION: Sill		
DATE:	Sept. 1, 2011	DRAWING NUMBER: <b>C-19</b>
DRAWN BY:	Lew Wood	
SCALE:	3/16"=1"	
NUMBER of MOLDS:	1	

**REQUIRED SPECIFICATIONS:**

1. Units are available with or without standard drips. Number and location of drip edges must be specified.
2. Unit lengths must be specified for molds that have end gates.
3. Colors other than standard gray are available and must be specified.
4. Finish textures other than standard smooth, dense concrete are available and must be specified.

**DESIGNSTONE AUTO CAD DRAWINGS** ▾

**C-37**

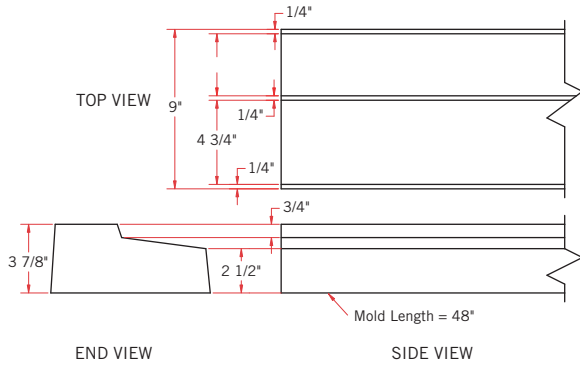

DESCRIPTION:		
Sill		
DATE:	Sept. 1, 2011	DRAWING NUMBER: <b>C-37</b>
DRAWN BY:	Lew Wood	
SCALE:	3/16"=1"	
NUMBER of MOLDS:	7	

**C-44**

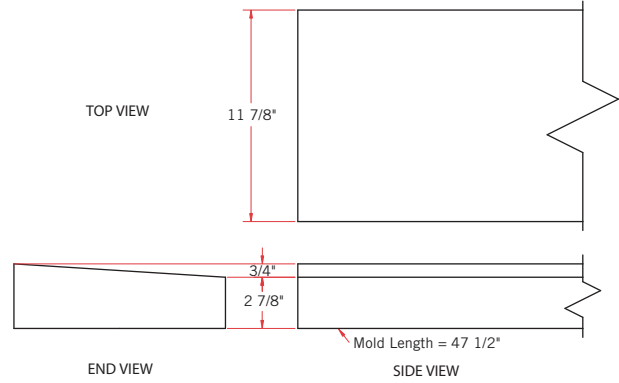

DESCRIPTION:		
Sill Std. drip available on 1 or both edges.		
DATE:	Sept. 1, 2011	DRAWING NUMBER: <b>C-44</b>
DRAWN BY:	Lew Wood	
SCALE:	3/16"=1"	
NUMBER of MOLDS:	4	

**REQUIRED SPECIFICATIONS:**

1. Units are available with or without standard drips. Number and location of drip edges must be specified.
2. Unit lengths must be specified for molds that have end gates.
3. Colors other than standard gray are available and must be specified.
4. Finish textures other than standard smooth, dense concrete are available and must be specified.

**CLEANING CONCRETE MASONRY** ▾ OBERFIELDS LLC. **recommended** procedure for cleaning concrete masonry surfaces.

**NEW CONSTRUCTION**

In order to reduce the amount of cleaning required at the completion of a building, walls should be cleaned each day. Mortar droppings should be allowed to harden slightly, then scraped off with a trowel or wood scraper. A small piece of broken block is also effective, followed by brushing with a stiff bristle or stainless steel wire brush (never use a steel wire brush).

Good masonry practices will minimize the amount of final cleaning significantly. Turning scaffolding boards at the end of the day and using sand or straw at the base of the wall will eliminate stains that are very difficult to remove later. Another important step is to cover the top of unfinished walls at the end of each day. This will prevent water from entering the cavities and will help prevent efflorescence. The plastic or tarps should drape at least two feet down each side of the wall.

Final cleaning will be easier if it occurs approximately one week after completion of walls (newly constructed walls must set 4 or 5 days to allow the mortar to harden prior to cleaning).

Never use high pressure cleaning! The use of high pressure power washers will most certainly alter the appearance of a concrete masonry wall and could cause unreparable damage to the building. A pressure washer with a maximum of 200 psi and a wide flare nozzle held 12 to 18 inches from the surface will give excellent results on most projects. Pre-wetting walls is a necessary first step. Work in sections from top down for best results.

**CHEMICAL CLEANING**

If good masonry practices are followed, chemical cleaning will seldom be necessary. If required, consult project specifications or call OBERFIELDS LLC for product recommendations.

Follow mix solutions and directions of manufacturer. Always pre-wet surfaces prior to application of any cleaning solution.

Oil stains, grease, graffiti or efflorescence removal, refer to N.C.M.A. Tek Notes 8.1, 8.2, 8.3, and 8.4. Copies of these teks are available from OBERFIELDS LLC, [www.oberfields.com](http://www.oberfields.com), or The National Concrete Masonry Association.

**CONCRETE LINTELS** ▾

**BLOCK TEXTURED LINTELS - NORMAL WEIGHT**

Lintel Length	Clear Span	Nominal 4x8				Nominal 6x8				Nominal 8x8			
		All. Load (lb/ft)	Factored All. Load (lb/ft)	Rebars	Weight (lbs)	All. Load (lb/ft)	Factored All. Load (lb/ft)	Rebars	Weight (lbs)	All. Load (lb/ft)	Factored All. Load (lb/ft)	Rebars	Weight (lbs)
24" (2'-0")	8"	5438	14592	1-#3 B	54								
28" (2'-4")	12"	3983	9240		63								
32" (2'-8")	16"	2740	6367		72								
36" (3'-0")	1'-8"	1997	4650	1-#3 T 1-#3 B	81	3978	9144	1-#3 T 2-#3 B	125				
40" (3'-4")	2'-0"	1517	3505		90	3025	5962		140	3035	7102		200
48" (4'-0")	2'-8"	956	2117		108	1912	3603		167	1912	4451		235
56" (4'-8")	3'-4"	654	1533		126	1310	2610		195	1305	3098	2-#3 T 2-#3 B	283
64" (5'-4")	4'-0"	472	1126		144	949	2053		223	941	2255		318
72" (6'-0")	4'-8"	354	854		169	716	1694		262	705	1709		354
80" (6'-8")	5'-4"	274	668		180	556	1342		284	544	1336		401
88" (7'-4")	6'-0"	382	727		1-#3 T	198	764		1240	1-#3 T	307	787	1526
96" (8'-0")	6'-8"	311	643	1-#4 B	216	624	1097	2-#4 B	335	640	1350	2-#4 B	472
112" (9'-4")	8'-0"	248	515	1-#3 T 1-#5 B	252	519	880	1-#3 T 2-#5 B	392	510	1081	2-#3 T	555
120" (10'-0")	8'-0"	248	515		270	519	880		418	510	1081	2-#5 B	590
128" (10'-8")	8'-8"	210	470		288	441	804		451				
136" (11'-4")	9'-4"	257	427	1-#3 T	306								
144" (12'-0")	10'-0"	223	395	1-#6 B	324								

**DENSE TEXTURED LINTELS**

Lintel Length	Clear Span	Nominal 4x8			
		All. Load (lb/ft)	Factored All. Load (lb/ft)	Rebars	Weight (lbs)
136" (11'-4")	9'-4"	221	394	1-#4 T 1-#6 B	318
144" (12'-0")	10'-0"	193	366	TRUSSED	336
160" (13'-4")	11'-4"	145	316	1-#4 T 1-#7 B	374
168" (14'-0")	12'-0"	128	297	TRUSSED	392

All dense concrete lintels have #3 inclined stirrups at 6" c/c welded to top and bottom reinforcing.

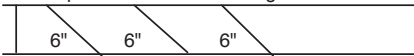

**STRUCTURAL DESIGN NOTES:**

- Loading shown is superimposed load capacity of lintel.
- Concrete compressive strength:
  - For Block Textured Lintels -  $f'c = 2500$  psi
  - For Dense Textured Lintels -  $f'c = 5000$  psi
- Reinforcing yield strength -  $f_y = 60,000$  psi
- Design based on ACI 318-02 and NCMA TR91B
- Minimum bearing length:
  - 8" for lintels less than 10 ft
  - 12" for lintels 10 ft and longer

**STEEL REBAR LOCATIONS FOR BLOCK TEXTURED LINTELS**

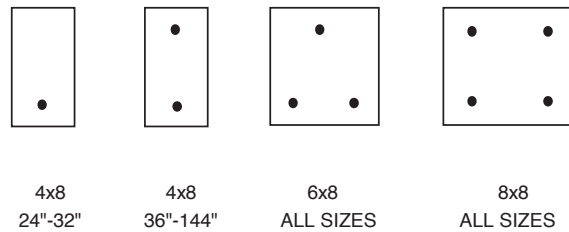

**GENERAL NOTES:**

\*Additional sizes in dense textured concrete lintels available on SPECIAL ORDER and require a customer supplied engineered drawing before we can quote.

- 4x8 Block Texture Lintels - scored one side
- 6x8 and 8x8 Block Texture Lintels - scored two sides
- Pallet Quantity for 4x8 Lintels: In layers of 10
  - 40 for units up to 48" length
  - 20 for units over 48" length
- Pallet Quantity for 6x8 and 8x8 Lintels: In layers of 5,
  - 20 for units up to 48" length
  - 10 for units over 48" length

## WATER CONTROL TECHNOLOGY (WCT) ▾

Why try to improve on one of the most trusted construction materials available? Water Control Technology (WCT) is based on preserving the superior performance characteristics of concrete masonry units while adding features that improve the ability of masonry wall assemblies to resist moisture penetration. Subtle changes were made to the top surface of each WCT units web to discourage water from crossing to the interior face shell. Corners and ends can use the WCT drainage zones without compromising aesthetics or performance. This innovation is fully compliant with ASTM C 90 and is a standard feature on all architectural masonry units produced by OBERFIELDS.

- WCT units feature integral drainage zones that direct moisture to the wall's drainage system.
- No special installation techniques required—cost effectiveness is assured.
- WCT units are suitable for corners and ends for a complete system.
- All units have integral water repellent in their mix design.
- WCT units meet or exceed ASTM C 90.
- Perfect for both single or multi-wythe walls.
- Offered in a wide variety of shapes and sizes.

## TESTING

WCT units were spray bar tested with no mortar (just gaps) alongside a traditional block design with a water flow rate equivalent to 180" of rain per hour for a half hour and then at a rate of 30" of rain for an additional 24 hours.

**RESULT:** the traditional block began to show moisture penetration to the interior surface after 11 seconds. The WCT block completed the 24 hour test without any evident moisture penetration to the interior surface of the wall.

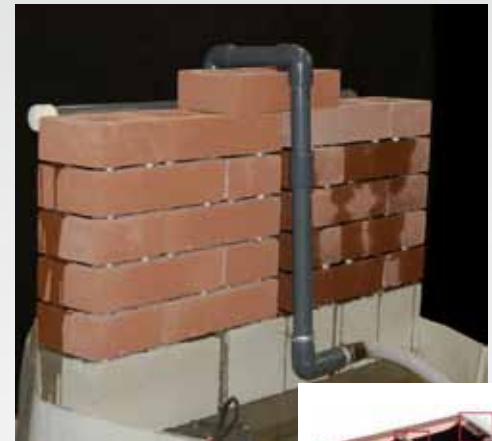



# A Masonry Design Service of OBERFIELDS LLC

## Smooth Face Architectural Concrete Masonry

“Smooth Face Architectural Concrete Masonry” is the designation used when a manufacturer produces a regular concrete block in a colored mix design. The only visual difference between Smooth Face Architectural Concrete Masonry and regular block...is the color.

For architects to achieve their design objective, it is important to understand the limitations of Smooth Face Architectural Concrete Masonry. This purpose of this MDS is to provide insight on the production process and field handling which collectively influence the finish and appearance of these block walls.

### At the Block Plant

#### TEXTURE

Smooth Face Architectural Concrete Block is produced using the same molds and production process as a regular block. The texture and aris of Smooth Face Architectural Block are very similar

to a regular concrete block. Smooth Face Architectural Block produced from white aggregate tend to have even rougher edges and irregular texture due to the physical characteristics of most white aggregates.

#### COLOR CONSISTENCY

Concrete products use synthetic iron oxides to achieve color. The colored iron oxides are batched into the concrete mix where they are bound into the cement paste. The pigmented cement paste then acts as a binding agent for the aggregates in the concrete product.

When concrete block are produced, this pigmented concrete mix is compacted in the mold under high pressure. This pressure forces the cement paste to the surface of the block. When you look at a Smooth Face Architectural Block, the color you see is predominately the cement paste. The concentration of cement paste that is forced to the surface varies block per block causing the overall color of the Smooth Face Block to change.

This is not true with Split Face, Ground Face or Sandblasted units. Split Face

Block are molded together and split apart after they are removed from the kiln. The concentration of cement paste forms on the opposite side of the finished surface. The cement paste on the surface of Sandblasted and Ground Face Block is either blasted or ground off during the manufacturing process. Both Sandblasted and Ground Face rely on the exposed aggregate matrix of the concrete to achieve their appearance.

To illustrate this point, view the Split, Sandblasted or Ground Face of an Architectural Concrete Masonry wall during construction. Next, look at the opposite side of that very same wall. The surface that removes the cement paste and exposes the aggregate matrix (split, sandblasted or ground) will show only a slight range of color. The surface with the cement paste remaining (smooth face) will show a wide noticeable color range.

Concrete block are cured in large kilns in a block plant. The goal of curing is hydration of the cement and is typically accomplished by elevating the temperature and moisture in the kiln. Temperature and



moisture significantly affect the color of cement paste. Because the temperature and moisture vary within the kiln, the color of the cement paste will vary throughout the block in the kiln. Split Face, Ground Face or Sandblasted, whose finished surface do not rely on the surface cement paste are not affected. Smooth Face Block is significantly affected.

### Handling At The Jobsite

#### CHIPPING

ASTM C-90 Standard Specification for "Load Bearing Concrete Masonry Units" recognizes that all concrete block projects experience chipping of the units from delivery and handling at the jobsite. "Minor cracks incidental to the usual method of manufacturing or minor chipping resulting from customary methods of handling in shipment and delivery are not grounds for rejection." The rough texture of Split Face and Sandblasted Block mask minor chips and allow the mason contractor to fill in a minor chip while the mortar joints are tooled. Small chips and rough edges are

very difficult and often not possible to blend into the Smooth Face Block due to its lack of texture.

#### SCRATCHING

The concentrated colored cement paste on the surface of a Smooth Face Block will scratch during customary methods of handling and delivery. One block rubbing against another removes the cement paste at the point of impact. This scratch appears as a white chalky line which cannot be removed by washing. Split Face are not as vulnerable to scratching as the aggregates of the exposed concrete matrix mask impact marks. Sandblasted Block are not affected as the entire surface has been etched by sand during the Sandblast process.

### Suggested Design Considerations For Using Architectural Smooth Face Block

The wide color range and handling blemishes inherent in Smooth Face Architectural Concrete Block Walls can be minimized by limiting this style of block to small areas of the wall at higher

elevations. An example is single course bands of Architectural Smooth Face Block within a field of Split Face.

Often Architectural Smooth Face Block are used for budget reasons after Split Face, Sandblasted or Ground Face Block have been eliminated due to their higher cost. One option is to use regular concrete block and stain the wall afterward. Deep penetrating masonry stains maintain the natural texture of the block and have excellent durability. These colored stains mask jobsite blemishes and blend in the wide range of color visible in regular concrete block walls.

If you have questions on this Masonry Design Service, or are interested in learning more on deep penetrating masonry stains, please contact our office at 614.252.0955.



**We think you'll agree-in concrete masonry, you won't find a more solid performer than OBERFIELDS.**

OBERFIELDS LLC is a value-centered business rich in tradition, innovation, and excellence, with a strong commitment to its people, customers, and the communities in which it does business.

OBERFIELDS LLC is Ohio's leading manufacturer, marketer, and technical resource for superior quality machine made and precast concrete products. OBERFIELDS also distributes a wide selection of top quality resale building materials merchandise to complement its innovative core product offering.

OBERFIELDS has over 50 years of experience serving the concrete products industry. Its five manufacturing plants, three direct sales and distribution yards, and network of dealers and distributors throughout six states provide residential and commercial markets with a full range

of concrete products and related materials including: standard concrete masonry; DesignBLOK® split-face architectural masonry; SpecBRICK®; DesignSTONE ornamental precast; lintels; interlocking concrete pavers and patio stones; retaining wall systems; sitedscape products; and a full line of concrete masonry building materials. You won't find a more complete line or more industry expertise in the entire region when it comes to standard or architectural concrete masonry. We have several Certified Construction Document Technologists on staff to provide full support for our products, including solutions to complex design and construction challenges.

OBERFIELDS serves many primary and secondary customers. Retail customers, do-it-yourselfers, contractors, distributors, government organizations, institutions, retail outlets, builders, architects, engineers, and developers all call on OBERFIELDS for service. Through five decades of service, OBERFIELDS has become Ohio's supplier

of choice for contractors, developers and builders by exceeding the demands of design flexibility, aesthetics, structural integrity, durability, fire resistance, sound reduction and thermal qualities.

Our tagline, Solid Performance in Concrete Products®, represents OBERFIELDS belief that high quality concrete products and superior customer service and support leads to a satisfied customer. OBERFIELDS prides itself on its ability to offer customized products and individually tailored solutions to meet your construction needs. OBERFIELDS technically sound sales, marketing, and customer service teams are prepared to answer questions relating to specifications, product applications, and designs or to take an order.

Call 614-252-0955, 740-369-7644, 937-885-3711 or 800-845-7644 or visit us on the web at [www.oberfields.com](http://www.oberfields.com)





**OBERFIELDS LLC**

**Sales - Corporate Office**

528 London Road  
P.O. Box 362  
Delaware, Ohio 43015-0362  
614-252-0955  
740-369-7644  
800-845-7644  
Fax 740-363-7644

**Sales and Manufacturing  
Landscape & Precast**

1165 Alum Creek Drive  
Columbus, Ohio 43209  
614-252-0955  
Fax 614-252-5858

10075 Sheenan Road  
Centerville, OH 45458  
937-885-3711  
Fax 937-885-7965

**Manufacturing  
Masonry**

471 Kintner Parkway  
Sunbury, Ohio 43074

4033 Alum Creek Drive  
Obetz, Ohio 43207



# OHIO'S LEADING MANUFACTURER, MARKETER, AND TECHNICAL RESOURCE FOR SUPERIOR QUALITY CONCRETE MASONRY PRODUCTS.



**OBERFIELDS.COM**

**CONCRETE PRODUCTS GROUP**

OBERFIELDS LLC is one of 13 original founding members of the Concrete Products Group. The Concrete Products Group (CPG) consists of regional market leaders in the concrete products industry. The CPG is organized to provide consistent, top-quality products to regional and national customers, from a local regional plants to anywhere in the United States. Our products such as Spec-BRIK WCT (Water Control Technology), Spec-Finish, and Spec-Thermal are produced with consistent specifications and production expertise.



**OBERFIELDS LLC IS A PROUD MEMBER OF:**

- American Institute of Architects-Ohio
- The Builders Exchange of Central Ohio
- Building Industry Association of Central Ohio
- Construction Specification Institute
- National Concrete Masonry Association
- Ohio Masonry Association
- Concrete Products Group

7.125"

