

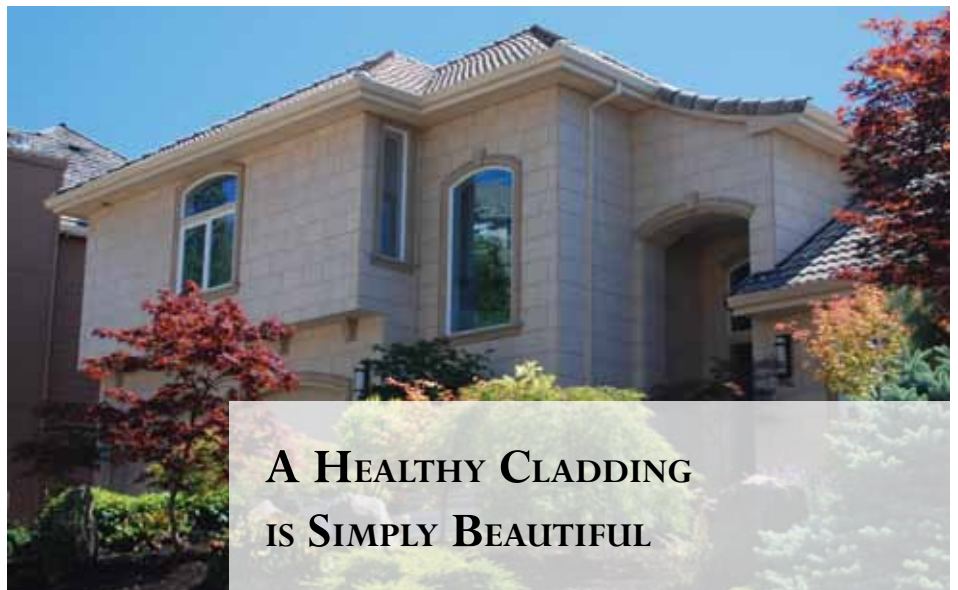

CASTIA STONE™  
DESIGN & INSTALLATION  
MANUAL



  
CASTIA  
STONE™

**A HEALTHY CLADDING  
IS SIMPLY BEAUTIFUL**



# CASTIA STONE™ DEALER/ INSTALLATION CERTIFICATION

Castia dealers and installers are certified so you'll be satisfied. Castia Stone takes great pride in a finished project and the complete satisfaction of our customers. We manufacture a high quality product and ensure a superior Castia Stone custom design. The quality of the final installation is equally important to the product and design.

For this reason, we have developed an extensive Dealer/Installation certification program which trains and certifies all our dealers and installers on Castia Stone standards for design, sales procedure, as well as proper installation of Castia Stone. This certification ensures that Castia Stone is installed in accordance with our manufacturer specifications. Prior to becoming authorized and certified, dealers and installers must complete a training class and participate in hands-on training which takes place both on and off the job site. Working closely with our dealers and installers, and making follow-up visits to the site allows, Castia Stone to provide the highest quality workmanship and service. Castia Stone stands behind our dealers and installers, and we are dedicated to providing continual service and support to our customers.



## BASIC INTRODUCTION TO CASTIA STONE INSTALLATION:

Castia Stone manufactures a siding system that has been used in North America since 1988. It consists of concrete tiles and trim that range in thickness from 5/8" - 4". The tiles are attached using an embedded bracket that creates an 1/2" air space between the tile and the substrate wall. This gap allows for proper drainage and ventilation. All seams are caulked with a special commercial-grade sealant and then sanded for a mortared look.

Castia Stone is installed over a proper building wrap and attached directly onto the building substrate. Unlike brick, the installation of Castia Stone does not require angle iron or other reinforcements. Each tile has embedded brackets that have a hole at each end. This allows the tile to be installed either right-side-up or up-side-down. To fasten the tile to the wall, stainless steel screws are driven through the bracket holes into the substrate. Cutting Castia Stone is done with a good quality circular saw fitted with a dry cutting diamond blade. (See your circular saw instructions for details about use/installation of blade.)

At this time, the seams are caulked with Tremco Dymonic™ Caulking or Dow Corning Silicone weatherproofing sealant. The caulk seams are then covered with sand to give them a mortared appearance. We recommend sand from PermaColor Quartz, an Estes company, ([www.permacolorquartz.com](http://www.permacolorquartz.com)), however, you can use sand from any supplier you feel will maintain the look of the Castia Stone. The easiest way to apply the sand, quickly and without waste, is to use a Central Pneumatic 95793 gun. The top-mounted hopper will hold up to 21 oz. of blast media with a fully adjustable flow valve for precise control. With the pressure set to about 5lbs, it can spray sand so that it coats the surface of the caulk evenly. Or, you can use a paintbrush to manually brush the sand over the caulk.

**Note: Proper installation of Castia Stone is contingent upon all other aspects of the construction completed in direct compliance with local building codes and proper engineering and architectural design.**

# PRIOR TO THE CASTIA STONE INSTALLATION

## WEATHERPROOFING

### Wall Sheathing

The wall sheathing must meet U.B.C. Code. Castia Stone recommends using ½ inch CDX plywood sheathing (with studs on 16” centers behind) because it has a higher shear tolerance. This product was also used in the pull-out testing. Apply sheathing per manufacture’s specification.

Note: When using OSB (orientated strand board) as a substrate it is necessary for this material to have a minimum thickness of 7/16” in order to maintain our Castia Stone warranty. Whenever installing Castia onto a substrate that does not hold screws, for example Densglass, furring strips or hat channel must be installed to capture the screws to complete the installation.

### Pre Window Installation Flashing



### Post Window Installation Flashing

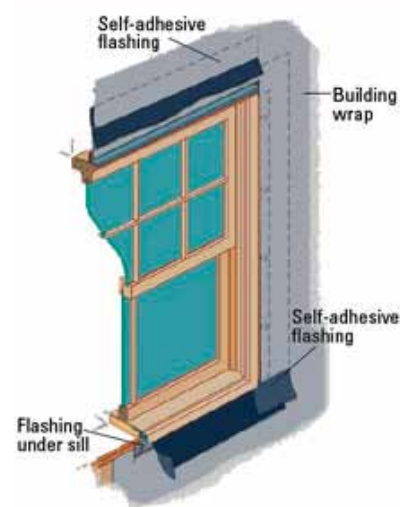

### Window Flashing

Windows are to be installed per manufacturers specifications. Castia Stone requires all windows to be installed with flexible flashing (Blueskin or equivalent). Twelve inch (12”) flashing must be installed on the sill so that it overhangs on the outside and then six inch (6”) flashing on the right and left side and then the top. When the building wrap is installed, pull out the bottom 12” flashing so that water will drain out onto the building wrap.

### Door Flashing

Install pan flashing on all doors so any water drains out. On the exterior, install 6” flexible flashing on the right and left sides and then on the top. Install the building wrap after all flashing is installed.



### Building wrap

The building wrap must meet U.B.C. Standard No. 14-1. Castia Stone recommends either 15lb. Felt paper, Tyvek, R-Wrap or other building wrap wraps of the installer’s choice. Remember, the idea is to let the house breathe and vent moisture, not wrap it in a plastic bag. Install the building wrap system per manufacture’s specifications.

To start first course, use a starter metal L strip at bottom of sheathing. Snap chalk line to help with alignment. Remove bottom hangers of bracket before installing.

# FRAMING DETAIL

1. Install Plinth Base at desired elevation first.
2. Install Capital Molding second.
3. Measure bottom of capital to top of plinth (B) and determine how you will need to cut the tiles. Fluted tiles are 18" tall and standard tiles are 12" tall. Make sure that you lay them out to look even on the top and bottom. Start from the bottom and work your way up.

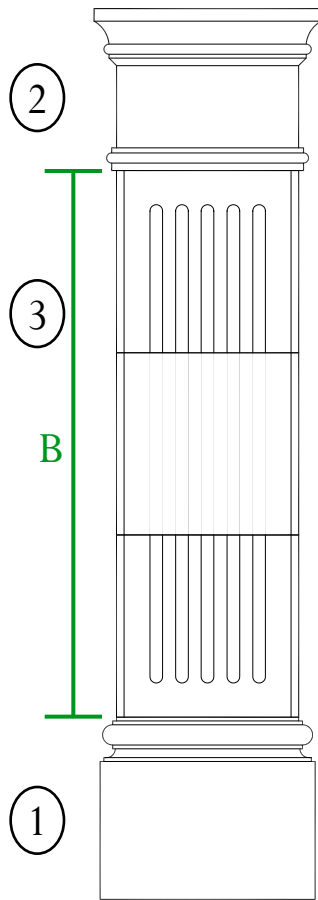

## Columns and Build-Outs

When framing for columns or build-outs, always keep in mind that you will have to cut the tiles and show that outside cut, if the framing isn't done to exact measurements.

### Framing Dimensions for Columns (A)

Columns Size	Net Frame (A)
24"	23"
18"	17"
12"	11"

The above column sizes are designed to fit with our product. Please do not use any other sizes. When specifying a framing size, make sure that the cut side dimensions (plywood to plywood) are framed exactly to the above measurements. This would include Fluted, Slate and Chiseled Stone. If you do not frame to these dimensions, the outer edge will show a cut on it and not finish well.

**Note: When covering a large build-out like a chimney or bay, you can cut the last tile. Just make sure that the cut side faces one of the inside tiles and not the corner. This way you can cover the cut with caulk at that joint.**

## Window Flashing

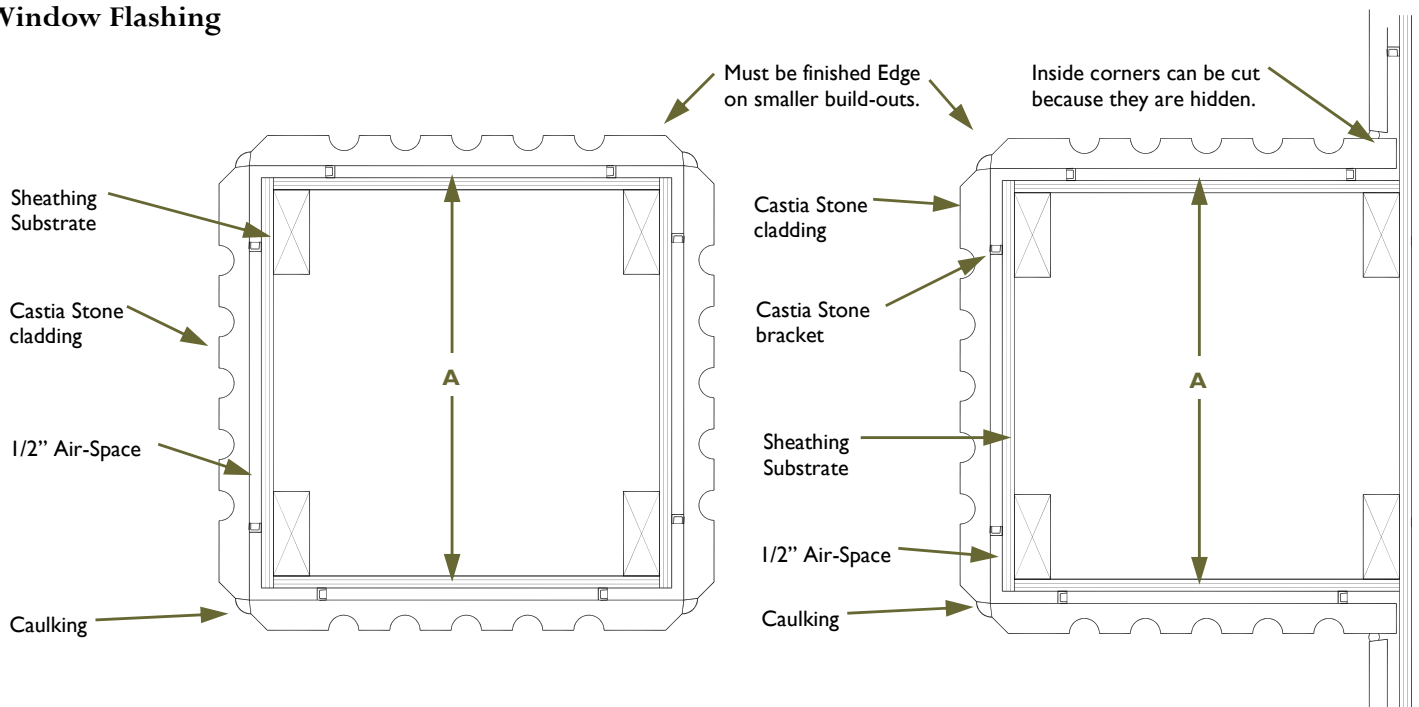

# PREPARATION FOR THE CASTIA STONE INSTALLATION

## Installation Plans

The Castia Stone plans can come from any architect. You may be provided with a rendering or a set of drawings for your project. When your Castia Stone is delivered you will receive all of the necessary tiles and trim items, along with sufficient caulk, sand and screws to complete your project. Be sure to check your delivery documents to verify that the order is complete. You may be provided with a rendering or a set of drawings for your project. Keep in mind that job site conditions can change which could require modifications to the original plans. As a Castia Stone installer you may be required to make design decisions yourself.

This is an **example** of a Castia Stone exterior design.



## Tools Required:

All the tools required can be acquired at local hardware stores.

Hammer Stapler

4" Grinder

Small Cordless Drill

Small Hammer Drill

Laser Level

Hammer

Safety Glasses

Putty Knife

7 1/4" Circular Saw (Makita)

Tape Measure & Pencil

4" Stiff Paint Brush

3' Level

Chalk Line

Utility Knife

Dust Mask

Central Pneumatic 95793 Gun

7" Diamond Dry-Cut Blade

48" x 24" working table

Caulking Gun and Tooling Tools

Torpedo Level

Tim Snips

Extension Cords & Pig Tail

Ear Protection

# TILE PREPARATION

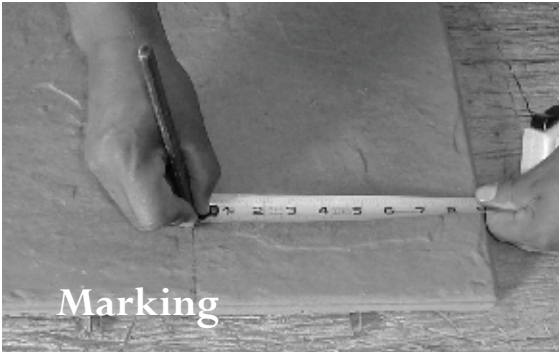

## Marking the Tiles

All the tiles can easily be marked with a pencil. For straight edges it is easiest to hold the measuring tape in one hand and hold the pencil against the end of the tape in the other hand and run it along the edge, producing a straight edge on the tile. Drywallers use the same technique when cutting sheetrock.



## Cutting the Tiles

After marking the tile there are two ways to cut the tile pieces. Always cut the tile dry, as using a wet saw or getting tile wet can stain the tile. Also, cut tile backwards to prevent chipping and to prevent the scoring line from being covered with dust.

**14" Chop Saw** - Just set the piece of tile or molding in the chop saw and cut just like you would cut a normal piece of wood or steel.

**7 1/4" Circular Saw** - Many installers find this to be one of the easiest ways to cut. After marking the tiles, set the tile on the table and freehand cut the tile on the specified line. This saw allows you to cut many different ways - arches, partial cut, etc.



## Scoring the Tiles

The reason you score a tile is to produce a "simulated seam". Typically, this is used between window mulls or where a vertical row of tiles may be used in a space that is 18" wide or less. By using a 4" dry cut mason blade to produce a channel, about 1/4" deep and 3/16" wide, you can produce a simulated seam without having to install to separate tiles.



## Grinding the Tiles

After making a cut it is important to grind the edge to produce a nice chamfer for the caulking to rest in. This eliminates having a sharp edge showing.

Optional: Cut beveled end of molding profiles straight to help create an even joint.

# TILE PREPARATION (CONT.)

## Stabilizing Single Bracket Tiles

The use of rocker bumpers (a 1" screw placed on either side of the bracket before installation of the tile) will maintain stability of tiles with one bracket. If you do not use the rocker bumpers to stabilize the tile, the tile will rock back and forth on the one bracket. The rocker bumpers can also be used in other applications to make sure that the 1/2" airspace is always present. Another way to stabilize tiles with a single bracket is to affix a 1/2" shim to the wall behind where the tile will be placed. This ensures the 1/2" space without having to measure exactly how far out of the backer a screw protrudes.

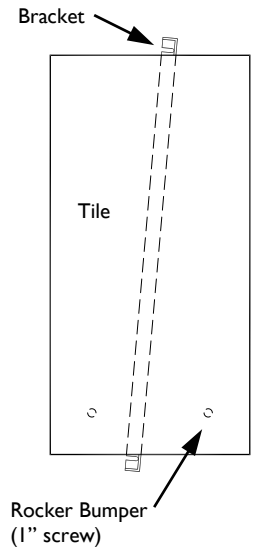

# MOULDING DOORS & WINDOWS

## Cutting and Installing Moldings

When putting molding around a window, you should install the sill return ends first. If they require a stretcher or stretchers between, plan your joint pattern so the spacing is equal.

Next install the upper left and right corners of the surround. If you're using a keystone, install that first, then plan your stretchers to achieve a pleasing symmetrical joint pattern. This applies to door surrounds as well. Always try to use as many full stretchers as practical.

Make a trace pattern of your sill ends as a guide to cut the adjacent tiles. Straight cuts should be made with a dry diamond blade in a circular saw, while you will need a small diamond blade grinder for the radius areas around the sill.

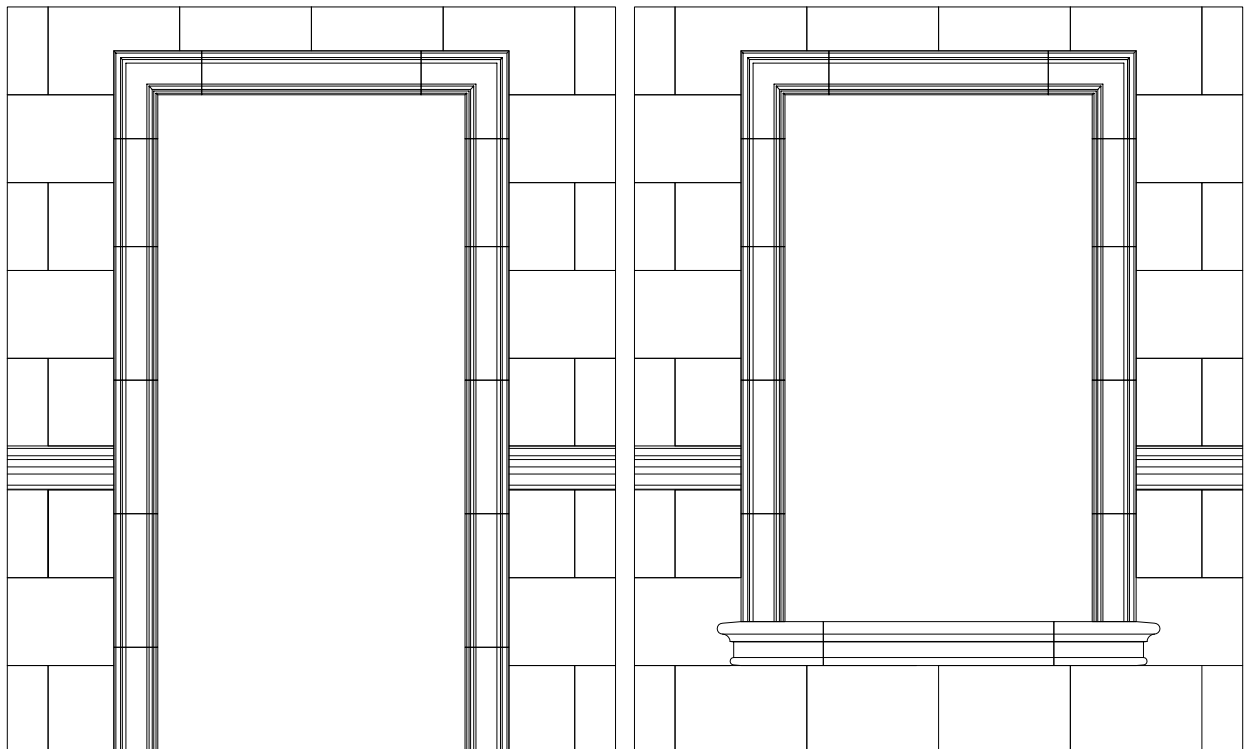



# WASHERS & SLOTS

## Attaching trim with washers and slots

You can fasten trim units to the substrate as well as to adjacent pieces using a 1/8" thick 5" diameter cutting blade on a grinder as shown in the photos below. First make a simple jig from 3/4" plywood so that the blade is cutting 1 1/4" from the bottom. After securing the trim and jig to the work surface, make a cut roughly 1" deep on each end of the trim piece (figure 1). After fastening the piece with bracket screws, insert a 1 1/4" fender washer in the slot and gently snug it in place with a 2" screw (figure 2). Then you can slide the next trim piece over the washer, adjust the washer screw as needed and attach the bracket screws.

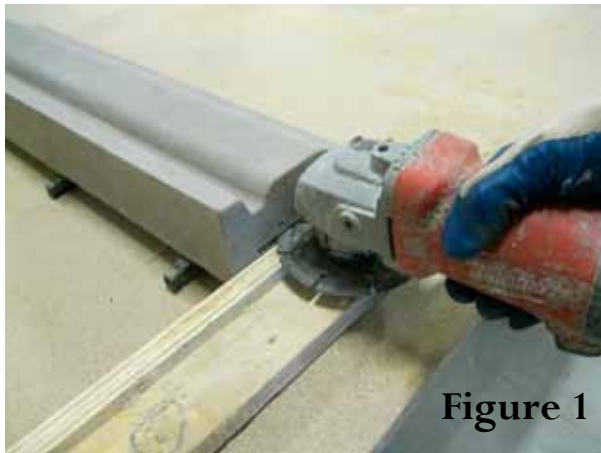

Figure 1



Figure 2

# ARCH DIAMETER FIT CHART NOTES

## To Use The Chart:

Measure the span and rise of your arched window (see drawing), then cross reference the two measurements on the chart on the next page to find which radius will give the best fit.

Here are three examples:

A 48" span with a 24" rise will work perfectly with a 4' radius.

An 84" a with a 12" rise will work with a 14' radius, but will have a slightly less perfect gap at the joint.

A 174" span with a 24" rise has no match; a custom arch trim would be required.

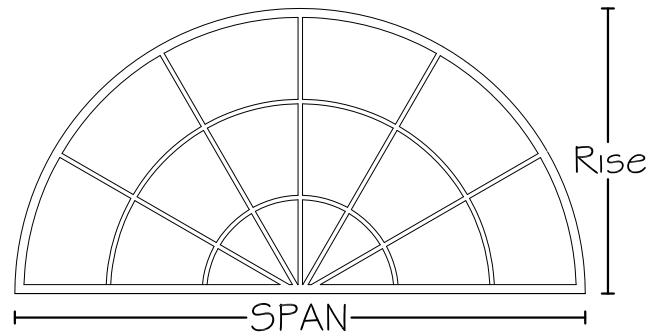

TYP. RADIUS WINDOW

## Color Key:

**Exact Fit**  
Best possible fit. Less than 1/16" gap at Arch Molding Joints.

**Less than Perfect**  
Some gap between joints but not more than 7/8".

**Not Recommended**  
Significant gap between joints or "scalloping" will occur.

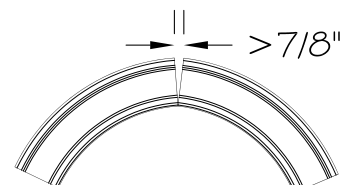
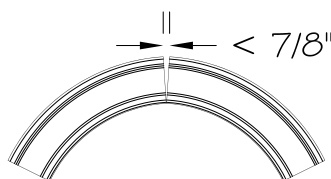
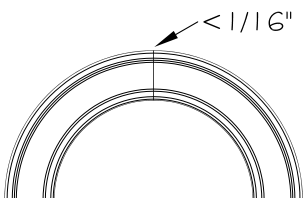

# ARCH DIAMETER FIT CHART

**Color Key:** █ Exact fit █ Less Than Perfect █ Not Recommended

Span		Rise in Inches																												
Inches	Feet	4	6	8	10	12	14	16	18	20	22	24	26	28	30	32	34	36	38	40	42	44	46	48	50	52	54	56	58	60
18	1.5	2																												
24	2.0	3	2.5	2	2																									
30	2.5	5	4	3	3	2.5	2.5																							
36	3.0	7	5	4	4			3	3	3																				
42	3.5	10	7	5	5	4	4																							
48	4.0	12	9	7	6	5	5	4	4	4																				
54	4.5	16	11	8	7	6	6	5	5	5																				
60	5.0	20	13	10	8	7	7	6	6																					
66	5.5	20	20	12	10	9	8	7	6	6	6	6	6																	
72	6.0	20	20	14	12	10	9	8	7	7	7	7	7	6	6	6	6	6	6	6	6	6								
78	6.5	20	20	20	14	12	10	9	8	8	8	8	8	7	7	7	7	7	7	7	7	7	7	7	7					
84	7.0		20	20	14	14	12	11	10	9	9	9	8	8	8	8	8	8	8	8	8	8	8	8	8	8	8	8	8	8
90	7.5		20	20	20	14	14	12	11	10	10	9	9	8	8	8	8	8	8	8	8	8	8	8	8	8	8	8	8	8
96	8.0	60	20	20	20	14	14	14	14	13	11	10	10	9	9	9	9	9	9	9	9	9	9	9	9	9	9	9	9	9
102	8.5	60	60	20	20	20	20	20	14	13	12	11	11	10	10	10	10	10	10	10	10	10	10	10	10	10	10	10	10	10
108	9.0	60	20	20	20	20	20	20	14	14	13	12	12	11	11	11	11	11	11	11	11	11	11	11	11	11	11	11	11	11
114	9.5	60	60	60	20	20	20	20	20	20	14	14	13	13	12	12	12	12	12	12	12	12	12	12	12	12	12	12	12	12
120	10.0	60	60	60	60	20	20	20	20	20	20	14	14	14	13	13	13	13	13	13	13	13	13	13	13	13	13	13	13	13
126	10.5	60	60	60	60	60	20	20	20	20	20	14	14	14	14	13	13	13	13	13	13	13	13	13	13	13	13	13	13	13
132	11.0	60	60	60	60	60	20	20	20	20	20	20	14	14	14	14	14	14	14	14	14	14	14	14	14	14	14	14	14	14
138	11.5	60	60	60	60	60		20	20	20	20	20	20	20	20	20	20	20	20	20	20	20	20	20	20	20	20	20	20	20
144	12.0	60	60	60	60	60		20	20	20	20	20	20	20	20	20	20	20	20	20	20	20	20	20	20	20	20	20	20	20
150	12.5	60	60	60	60	60	60	20	20	20	20	20	20	20	20	20	20	20	20	20	20	20	20	20	20	20	20	20	20	20
156	13.0	60	60	60	60	60	60	60	60	20	20	20	20	20	20	20	20	20	20	20	20	20	20	20	20	20	20	20	20	20
162	13.5	60	60	60	60	60	60	60	60	60	60	20	20	20	20	20	20	20	20	20	20	20	20	20	20	20	20	20	20	20
168	14.0	60	60	60	60	60	60	60	60	60	60	60	20	20	20	20	20	20	20	20	20	20	20	20	20	20	20	20	20	20
174	14.5	60	60	60	60	60	60	60	60	60	60	60	60	20	20	20	20	20	20	20	20	20	20	20	20	20	20	20	20	20
180	15.0	60	60	60	60	60	60	60	60	60	60	60	60	60	20	20	20	20	20	20	20	20	20	20	20	20	20	20	20	20
186	15.5	60	60	60	60	60	60	60	60	60	60	60	60	60	60	20	20	20	20	20	20	20	20	20	20	20	20	20	20	20
192	16.0	60	60	60	60	60	60	60	60	60	60	60	60	60	60	60	20	20	20	20	20	20	20	20	20	20	20	20	20	20
198	16.5	60	60	60	60	60	60	60	60	60	60	60	60	60	60	60	60	20	20	20	20	20	20	20	20	20	20	20	20	20
204	17.0	60	60	60	60	60	60	60	60	60	60	60	60	60	60	60	60	60	20	20	20	20	20	20	20	20	20	20	20	20
210	17.5	60	60	60	60	60	60	60	60	60	60	60	60	60	60	60	60	60	60	60	60	60	60	60	60	60	60	60	60	60
216	18.0	60	60	60	60	60	60	60	60	60	60	60	60	60	60	60	60	60	60	60	60	60	60	60	60	60	60	60	60	60
222	18.5	60	60	60	60	60	60	60	60	60	60	60	60	60	60	60	60	60	60	60	60	60	60	60	60	60	60	60	60	60
228	19.0	60	60	60	60	60	60	60	60	60	60	60	60	60	60	60	60	60	60	60	60	60	60	60	60	60	60	60	60	60
234	19.5	60	60	60	60	60	60	60	60	60	60	60	60	60	60	60	60	60	60	60	60	60	60	60	60	60	60	60	60	60
240	20.0	60	60	60	60	60	60	60	60	60	60	60	60	60	60	60	60	60	60	60	60	60	60	60	60	60	60	60	60	60

# INSTALLING THE CLADDING

## SUGGESTED LAYOUT DESIGN

The Castia Stone cladding system should be installed after the moldings have been installed. The cladding will butt up to the moldings. All of the cladding will be installed per the supplied plans. Keep in mind the elevations may be slightly different at construction. Start at the bottom working your way up the wall per the plans. The layout may be important depending on the type of product that is being installed.

### Chiseled Stone Cladding

The layout on chiseled stone is a random pattern. Tiles should be installed similar to the order that they are packaged, otherwise you may end up with all of one size towards the end of the job. Be sure to have nice large end pieces.

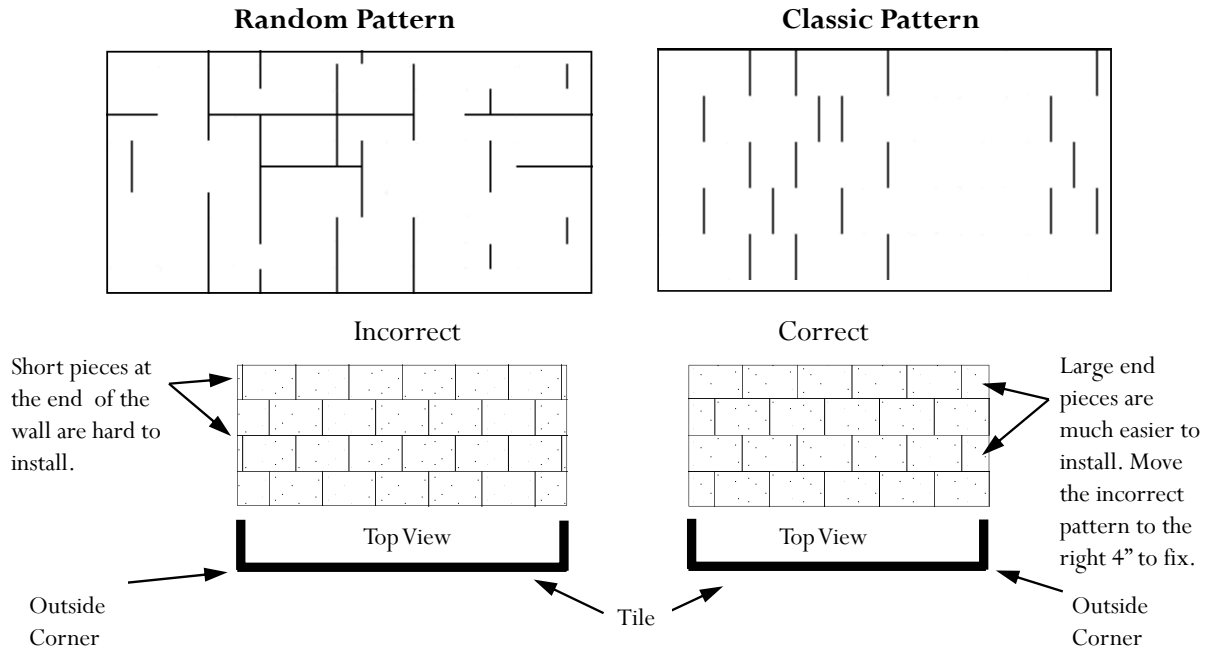

### Slate Cladding

The layout on the Slate tile is a specific pattern. When installing a wall make sure that you measure out that wall so that your first or second row does not end with a very short piece. If this happens, move your layout to the right or left approximately 4" and start there. Often you can start your pattern on the outside corner (A) with a full tile and finish at the inside corner (B) with a cut tile. Your second row will start with a half of a full tile (9" long).

Make sure that cut edge is at seam of next tile and not on exterior corner. Follow the same guidelines for a stacked pattern as the staggered pattern. Make sure to position the tiles to create equal lengths at the edges.

Note: The figure to the right shows the layout on an outside wall with two outside corners.

### Staggered Pattern

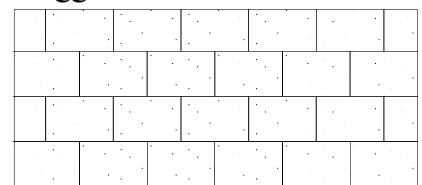

### Stacked Pattern

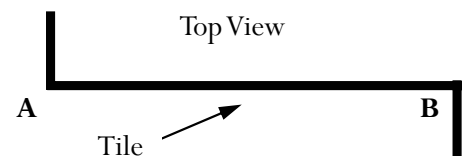
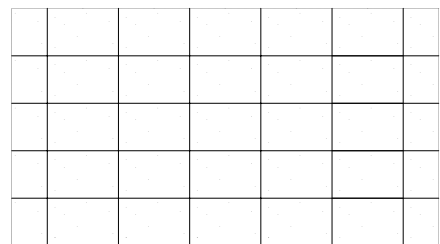

# CAULKING & FINISHING THE JOINTS

## General Notes

Caulk joints should never be so wide that the caulk has an opportunity to come in contact with the substrate. If necessary use backer rod. There are two steps involved in creating a proper joint. The first step is applying the caulk, and the second is sanding the caulk to create the appearance of a mortared joint.

## Caulking

It is important that all joints are clean and dry before applying caulk in order to achieve maximum adhesion. Always brush off any dust created when cutting tiles or trim, including adjacent tiles, so as to avoid possible contamination or discoloration of material. Cut the end of the caulk tube at an angle (photo 1) to make it easier to run the tube along the joint (photo 2) and cut down on the amount of tooling required to finish the joints. Tooling (photos 3, 4) is essential to ensure critical adhesion and mimic the look of tooled mortar. The warmer the outside air is the more difficult the caulk will be to work with. Try to caulk in the morning on summer days and the afternoon in the winter.

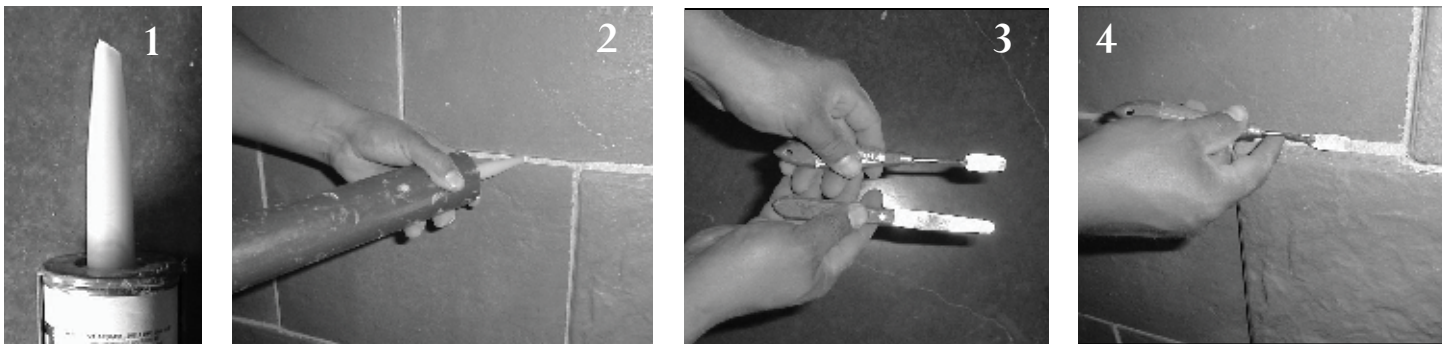

## Sanding

Immediately after caulking, before the caulk has a chance to skin over, apply a layer of sand to all the joints in order to achieve a mortared appearance. This can be done in a couple of ways: you can put sand in a small container and spread it on the caulk joints with a wide stiff paint brush, or you can use a Central Pneumatic 95793 Hopper Gun. We have found that the gun can hold up to 21 oz. of sand and when used on a low pressure setting (about 1 lb.) it will quickly and easily spray the sand so that it coats the surface of the caulk evenly with minimal waste.

**Note:** Use caulking and sand to cover exposed cuts. Colored grout can also be used.

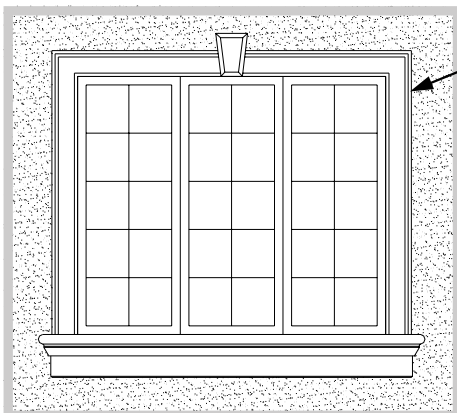

3/8" Caulked Gap

## Stucco and Moldings

When using Castia Stone moldings with different or existing materials, leave a 3/8" gap between the material and the Castia Stone molding to account for expansion and contractions. Fill the gap with a matching caulking. To make caulking moldings easier, cut the caulking tip to have a larger opening to help fill joints completely.

# INSTALLATION DETAILS

## CAULKING DETAILS

### CAULK OUTSIDE QUIRKED CORNER

You can achieve a quirked corner by grinding a 45° bevel along a vertical edge, leaving about 1/4" of flat surface (see diagram at right). When using a quirked corner apply caulk as you would at any vertical joint. If the gap is large enough to potentially allow caulk to contact the substrate, use backer rod.

#### Top View

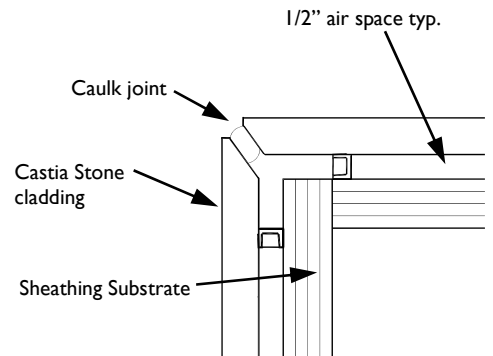

### CAULK OUTSIDE CORNER

The tiles must come together at their bases and caulking must be applied in the space between them, as shown to right.

#### Top View

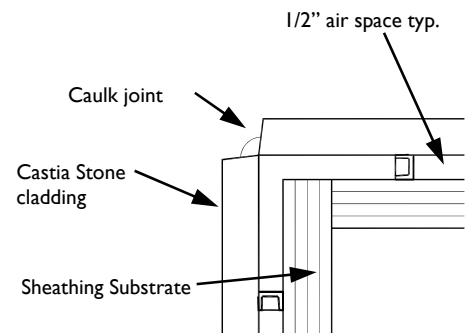

#### Top View

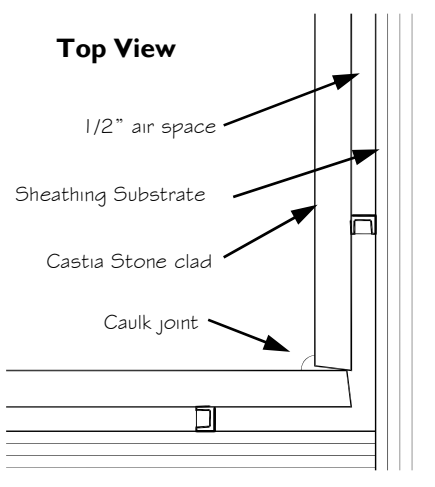

### CAULK INSIDE CORNER

The tiles must come together. The end of one tile must intersect the face of another tile with caulking in the gap left by the angled end, as shown to left. The caulking line must be a minimum of 1/4" between all Castia Stone products.

### CAULK WALL

The tiles must come together at their bases and caulking must be applied in the space between them, as shown to right.

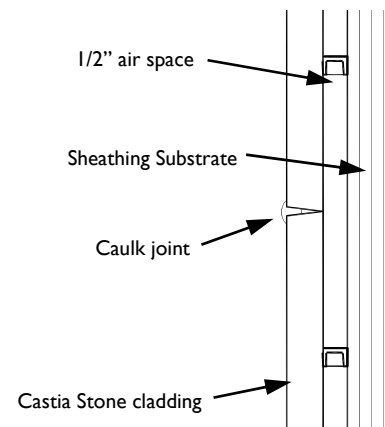

## OPENING DETAILS

### OPENING WITH TRIM

When starting the installation above any brick mold, always install standard Z-Flashing to keep any water from going behind the brick mold. Leave the bottom of the tile open next to the Z-Flashing so any moisture may drain properly.

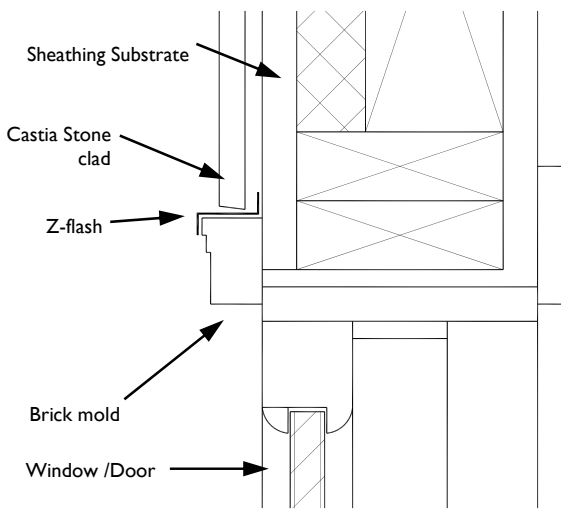
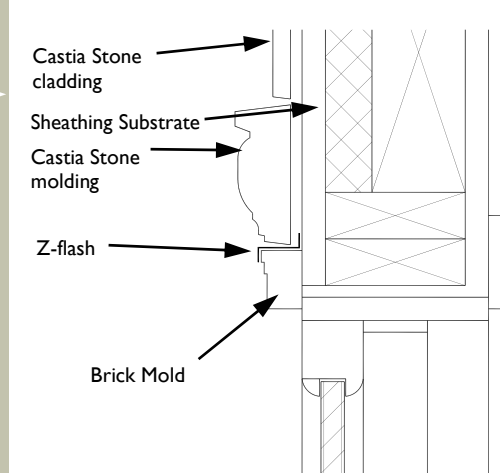

### OPENING WITHOUT TRIM

When starting the installation above any brick mold, always install standard Z-Flashing to keep any water from going behind the brick mold. Leave the bottom of the tile open next to the Z-Flashing so any moisture will drain.

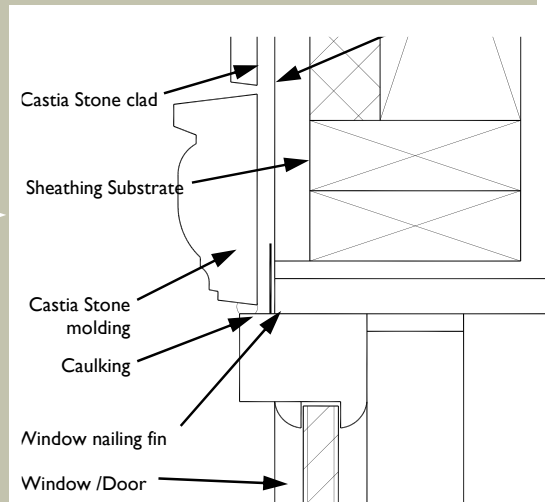

### FINNED OPENING WITH TRIM

The finned opening works just like the brick mold, except there is no need for Z-Flashing because the finned window acts as its own flashing.

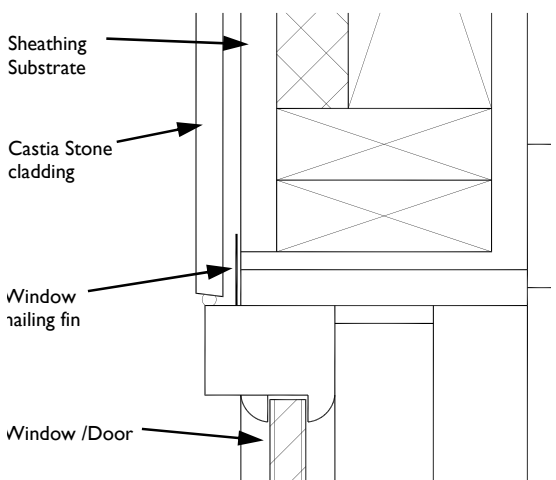

### FINNED OPENING WITHOUT TRIM

The finned opening works just like the brick mold, except there is no need for Z-Flashing because the finned window acts as its own flashing.

## TILE START EDGE DETAILS

### CUT EDGE START

Use a specified J-Channel to start any tile that has a cut bottom edge, usually used where tile starts from a roof line as shown. The channel will cover the cut edge and it will also keep the tile from pulling out at the bottom. Another options is to use an L-shaped starter strip.

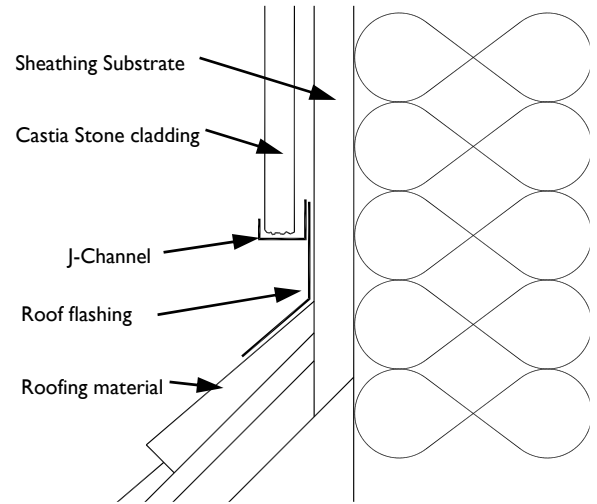
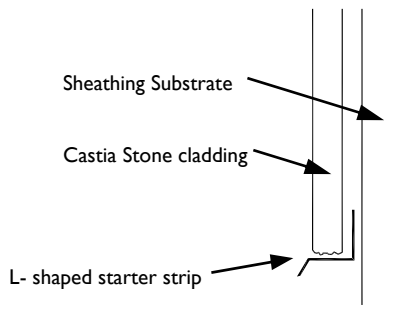

**Note:** You have the option of using an L-shaped starter strip. In places of high moisture, stainless steel starters are recommended.

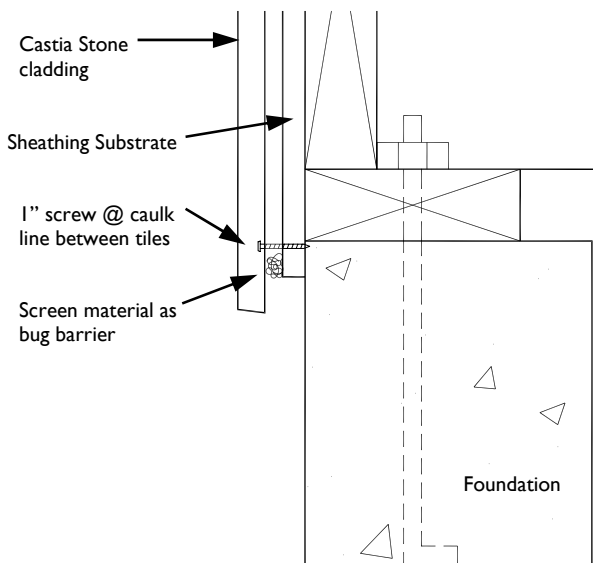

### CLEAN EDGE START (SIDE VIEW)

When starting the first row of tile, install tile minimum 2" below the wall sheathing. Once the first course is installed insert screening material behind bottom of tile to create a bug barrier.

When attaching tile to a concrete wall, attach 3/4" Pressure Treated Plywood and then screw the tiles into the plywood with 5/8" screws. Make sure the plywood is attached firmly with adhesive and some type of anchor. Always check local building codes when doing this.

### CLEAN EDGE START (TOP VIEW)

Attach a screw at minimum of every other tile in the vertical caulk line to keep bottom edge from pulling out.

### CLEAN EDGE START (FRONT VIEW)

When installing a clean edge row such as a bottom starter row, you must first cut the brackets at the bottom edge. To pin the bottom, first use a grinder to score a 1/8" notch in the side of the tile about one and a half inches up from the bottom. This will allow you to install a #6 x 1" screw between that tile and the adjacent tile without driving them apart.

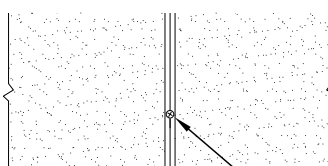
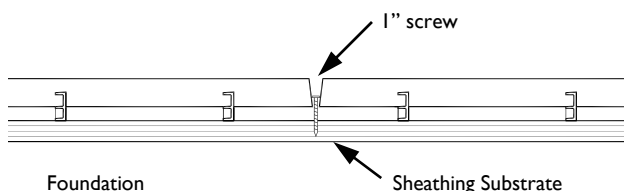

SCREW [BEFORE CAULK]

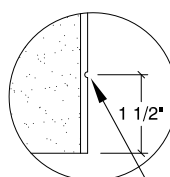

NOTCH FOR SCREW

## EAVE DETAILS

**NOTE: Gutters must maintain a 3" clearance from all adjacent walls where Castia Stone is applied.**

### SOFFITED EAVE

Wood soffit needs a 5/4" x 5/4" cedar trim piece. This still allows for the airspace to vent and also looks like a finished detail to the soffit.

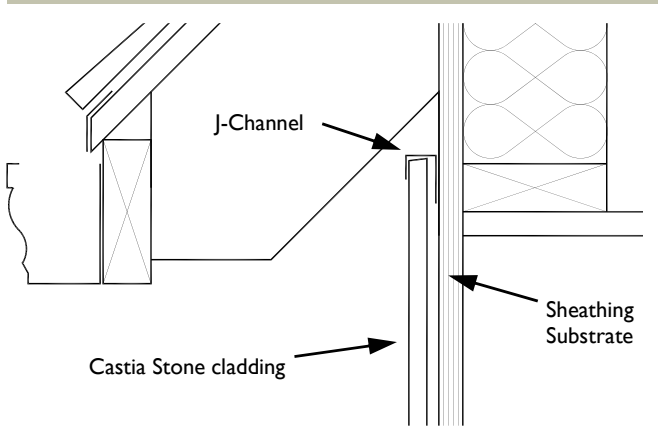
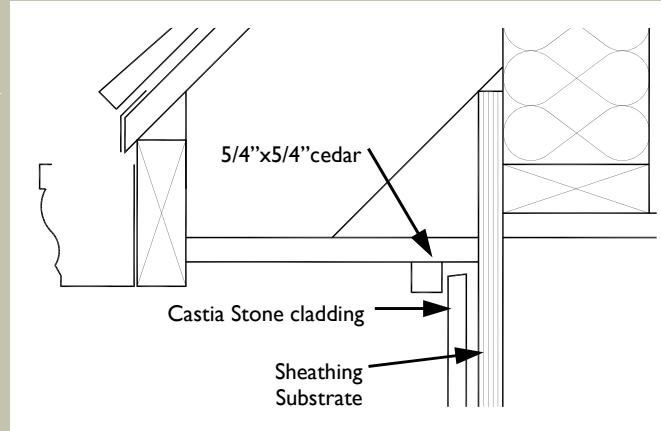

### OPEN EAVE

To finish this way, take the Top J-Channel and turn it upside down. Cut the tile about 3/8" short so that you can slide the tile up into the J-Channel and then drop the bracket behind the other tile below.

### NON WOOD SOFFIT

When using either a vinyl or metal soffit, you will have to use the Top J-Channel and turn it upside down. Cut the tile about 3/8" short so that you can slide the tile up into the J-Channel and then drop the bracket behind the other tile below.

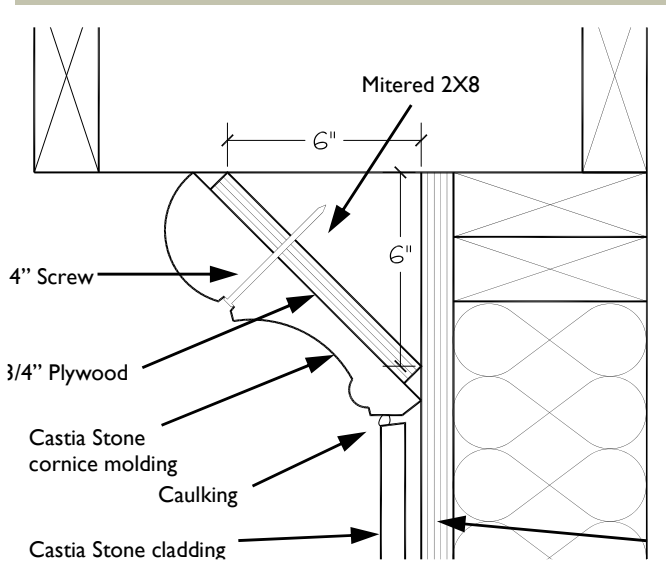
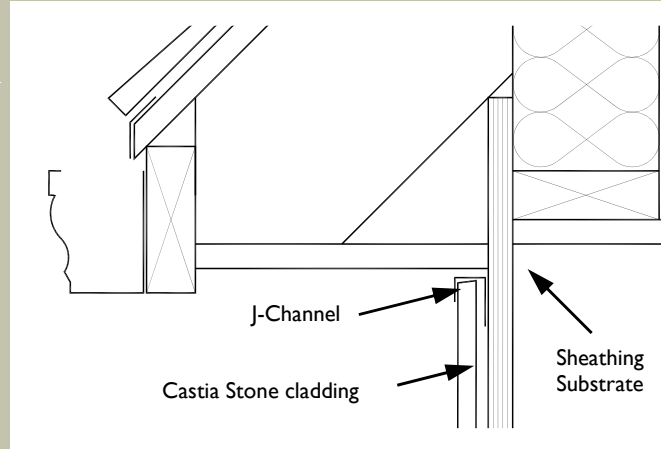

### EAVE WITH CORNICE

The eave should be framed in with a triangular piece in the corner that is 90 degrees and has two (2) six-inch legs. Attach the cornice molding with at least four (4) 4" screws through 1/2" horizontal groove on face.



**CHIMNEY WITH TRIM**

When trim is used at the top of a chimney, install a 2" x 4" blocking around the top perimeter so that the flashing can be installed over the top and intersect with the trim. Caulk at the intersection of the trim and the flashing. To finish off the chimney install a decorative cap for a final touch.

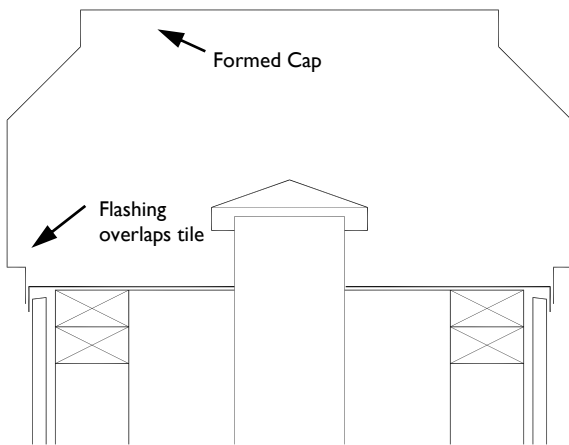
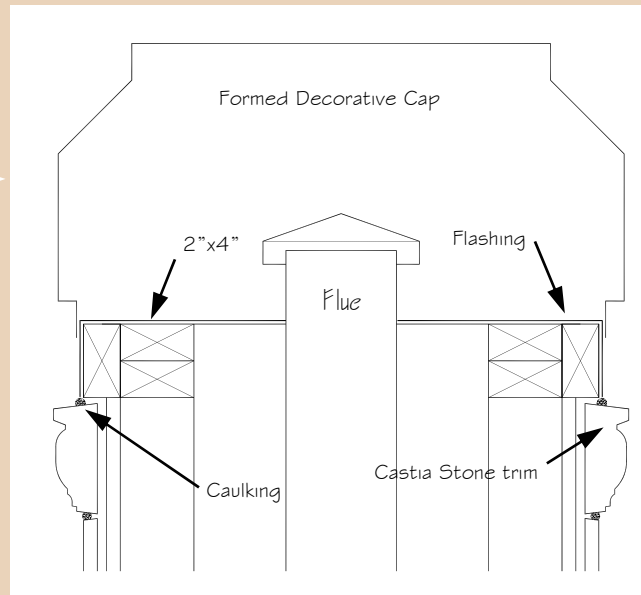

**CHIMNEY WITHOUT TRIM**

Bring the cladding to the top of the framing and then install the flashing over the cladding and down about 2".

**CHIMNEY EYEBROW CAP**

For eyebrows on the chimney, install typical roofing material over sheathing substrate. Make sure that all the cladding above the roofing material overlaps so that any water will drain correctly. Flashing is required where roof overlaps cladding and where cladding continues above roofing material.

Be sure to use an L-channel (A) or J-channel (B) where specified to start the roof line to the chimney eyebrow cap.

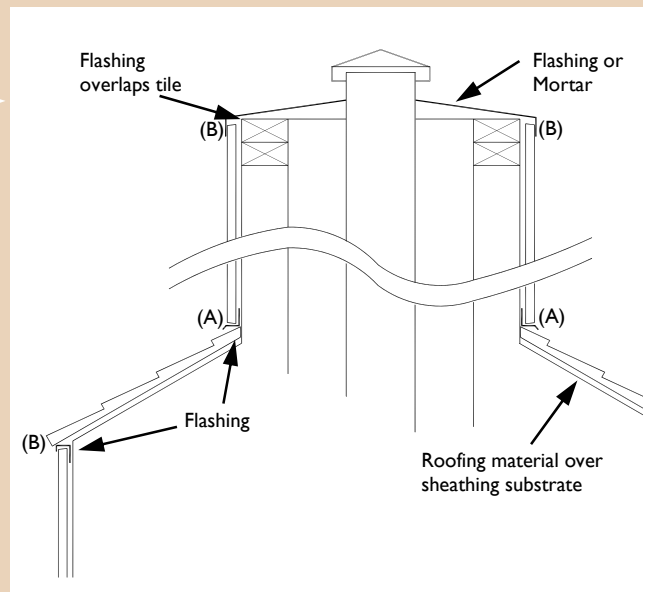

## TRANSITION DETAILS

### TILE TO SIDING WALL

When making a transition from Castia Stone to siding on a flat wall, use a cedar 2" x 2" between the Castia Stone cladding and the siding. Vinyl or metal siding transition should be done with a standard J-Channel.

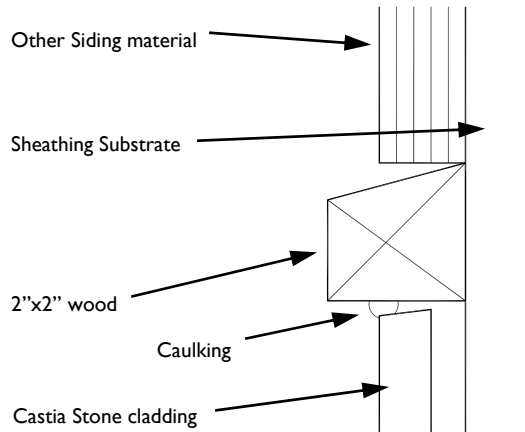
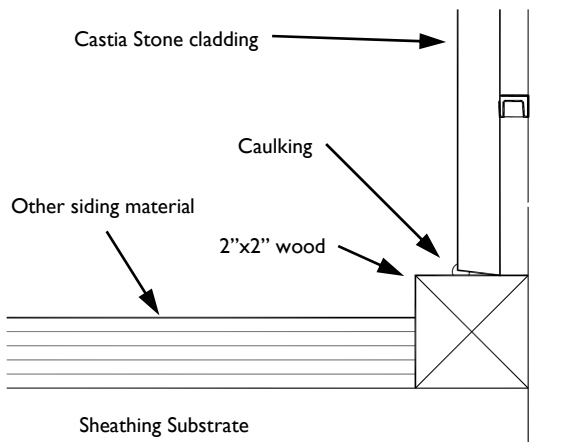

### TILE TO SIDING AT INSIDE CORNER

When a transition from Castia Stone cladding to siding is at an inside corner, place a cedar 2" x 2" in the corner and intersect both the siding and the Castia Stone cladding. Properly caulk the intersection.

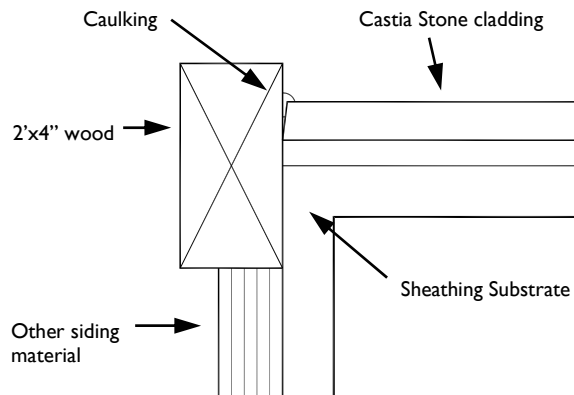

### TILE TO SIDING AT OUTSIDE CORNER

If you need to intersect at an outside corner, use a cedar 2" x 4" on the outside corner. Make sure that the 2" x 4" is mounted approximately 2" past the outside corner framing. This will allow for a proper caulking line from the Castia Stone cladding to the 2" x 4".

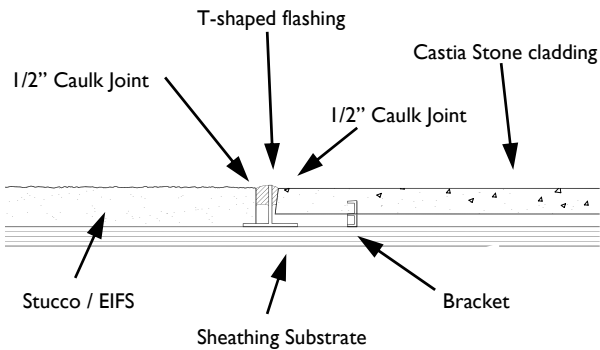

### TILE TO STUCCO

Stucco/EIFS installers generally attach a T-shaped flashing at the transition between the stucco/EIFS and Castia Stone. When transitioning from Castia to EIFS leave a 1/2" space for backer rod and caulking to allow for expansion and contraction.

## PIER CAP DETAILS

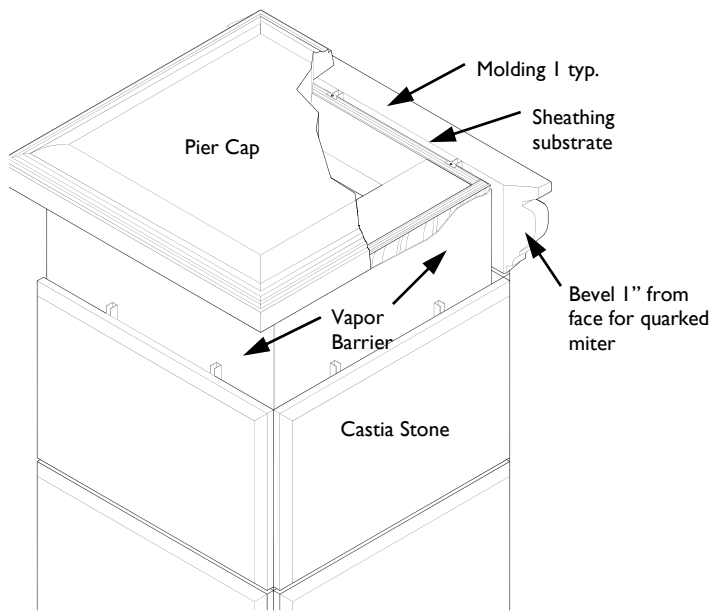

### ◀ QUIRKED MITER PIER CAP

15", 21" and 27" pier caps are designed to fit piers framed at 11", 17" and 23" respectively. Typically, a "Type 1 Molding with End Detail" of the appropriate length is installed between the pier cap and the cladding below. Bevel cut the molding 1" from the face at each end for a quirk miter (see diagram). To fasten the molding, pre-drill through the top of the molding at a 45° angle (see diagram) and attach with 3" S.S. screws. Fasten the pier cap with an exterior grade construction adhesive.

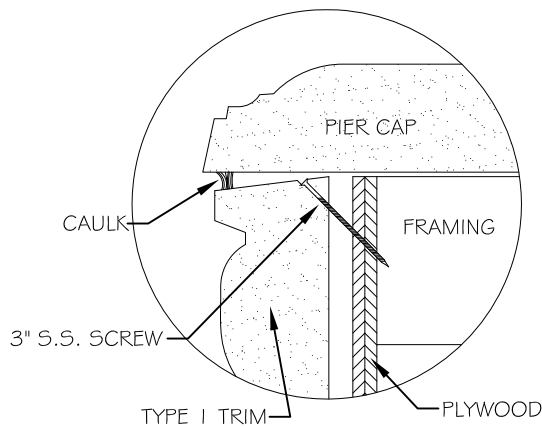

### ◀ PIER TRIM ATTACHMENT DETAIL

# INSPECTIONS

A thorough inspection should be conducted both before and after installation by the installer and the homeowner to ensure the following quality standards are met or exceeded. A Castia representative can be contacted if questions arise.

## **Pre-Inspection:**

- Building paper correctly installed.
- Opening surrounds properly sealed.
- All materials needed to complete job on site.
- Start measurements as per plan.
- All flashing installed correctly.
- All shims/build-outs completed neatly.
- Tiles and moldings must be clean and dry prior to caulking.
- Use backer rod as required.
- Apply caulk within temperature guidelines.

## **Post-Inspection**

- All moldings are installed plumb, level and square.
- All moldings are clean.
- Obvious color harmony maintained.
- All openings are cut to fit neatly.
- All moldings are fastened as per design.
- Installation minimized waste.
- Tiles are installed plumb, level and in line.
- All cuts are square and fit neatly.
- Tile fit is tight in all directions.
- Layout is correct as per plan.
- All tiles are attached as per design.
- Fixtures, mailbox, numbers, etc are replaced.
- All joints and openings are caulked properly.
- All windows and doors caulked properly.
- Sand is applied thoroughly and neatly.

## CARE AND MAINTENANCE OF YOUR CASTIA STONE EXTERIOR

A small investment in maintaining your Castia Stone cladding system pays in the long-term appearance and protection of your home. Site conditions can play a big part in keeping exterior surfaces clean. To minimize cleaning and keep exterior surfaces clean, trim bushes to allow good air circulation, cover soil with mulch or stone, and maintain proper gutter drainage.

### **Visual Inspection of House Exterior**

The purpose of the visual inspection is to detect potential problem areas which could allow water entry. Specific areas that may be problematic are addressed as follows:

- Roofs: Ensure that all flashings are functional for proper drainage (away from and off of the roof).
- Gutters & Downspouts: Should be properly sloped and cleaned regularly.
- Chimney: Make sure that water is directed away from chimneys.
- Windows & Doors: Check window/door frames for frame separation at corners. Check the weeps to ensure that they are clean and functional. Check wood windows to ensure that exposed edges have been primed and painted. Check windows/doors to ensure that they have been caulked to the abutting cladding.
- Penetrations, Attachments & Terminations: Inspect to ensure the presence of proper sealant joints and flashings.

**Note:** Required repairs should be performed by a qualified professional.

# GENERAL CLEANING

## Removing Dirt and Airborne Pollution

Light dirt or pollution can be removed by spraying a concentrated stream of water on affected areas. A garden hose and nozzle are usually adequate. For heavier buildup, first wet the area to be cleaned, then, using a solution of 1 gallon warm water and 1 cup of trisodium phosphate (or liquid soap such as dish washing liquid), lightly scrub with a bristle brush. Rinse with water. Do not power wash caulked areas.

**CAUTION:** If power washing by a professional, keep pressure under 1,500 psi and use cold, unheated water. Hold sprayer with a fan-tip nozzle at a 45° angle from the wall (not perpendicular) and keep spray tip at least 18" from surface. Washing any closer or harder will remove sand and possibly caulking from the joints.

## Removing Mildew and Algae

Even though Castia Stone products include mildew-retarding agents, mildew and algae can grow when conditions are excessively warm and moist, especially if the area is shaded and prone to dirt accumulation. A mild soapy solution may be all you need; however, you may need to increase the amount of soap for heavier growth. First, protect all adjacent plants and materials with drop cloths. After spraying the affected area with water, scrub with a bristle brush using a solution of 1 gallon warm water, 1 quart bleach and 1 cup trisodium phosphate or liquid soap. Rinse with water.

## Removing Rust and Copper Stains

You might find rust and copper stains around outdoor faucets. To remove these stains, use Sure Klean™ Ferrous Stain Remover or Sure Klean™ Copper Stain Remover T515 which are available at most hardware stores. Mix a solution of 20 parts warm water and 1 part Sure Klean™. Lightly scrub with a bristle brush and rinse with water.

## Removing Graffiti

Scrub with a soft bristle brush and a solution of 1 gallon warm water and 1 cup liquid soap. This may not work on oil-based spray paints. If this is not successful, contact your local paint distributor for additional recommendations. Always test any product in a hidden area to make sure that removal method will not damage the Castia Stone. Castia Stone does not apply anti-graffiti sealers. Please see previous page for factory for recommendations concerning anti-graffiti sealers .

## Efflorescence

Pre-cast colored concrete may or may not make natural changes over the life of the home depending on the climate conditions that exist in your area. Efflorescence is a calcium stain that is emitted from concrete through its pores.

Efflorescence may occur displaying some white powdery residue on the surface of the tiles and color may fluctuate and change, especially in the first six months after installation. However, it represents only a visual impairment.

If efflorescence appears it should be removed promptly in order to protect the color of the tile from fading. To remove use a soft brush or sponge to wipe off the white powder. Slightly wetting the brush or sponge may help with removal. Persistent stains can be removed with a 5:1 water & vinegar solution again using a soft brush. Always test a small area prior to applying any solution when tiles are clean and dried they should be resealed with an appropriate concrete sealer.

# CASTIA STONE

## SPECIFICATION INFORMATION

### Caulking

Caulking choices have been designed specifically to adhere to concrete and allow for joint movement. Please look at manufacturer websites for spec sheet, color choices, application and warranty information.

Tremco Dynamic™ \*      [www.tremcosealants.com](http://www.tremcosealants.com)

Dow Corning®      [www.dowcorning.com](http://www.dowcorning.com)

- 791 Weatherproofing Sealant

- Contractors Weatherproofing Sealant

\* preferred

### Castia Stone Specified Installation Materials

Caulking (see above)

Silica Sand

Stainless Steel Screws - Fastenal 6" x 1" stainless steel, pan head square drive

J-Channel (flashing)

L-Channel (flashing)

### Masonry Substrate

### Castia Stone Specified Fastener

7/16" Minimum CDX plywood

#6 Fastenal 6" x 1" stainless steel, pan head square

7/16" Minimum OSB plywood

#6 Fastenal 6" x 1" stainless steel, pan head square

Concrete (2000 psi minimum)

Torx Bit 3/16" Fastener (Minimum 1" embedment Depth)

Concrete Masonry Unit Block

Torx Bit 3/16" Fastener (Minimum 1" embedment Depth)

Brick

Torx Bit 3/16" Fastener (Minimum 1" embedment Depth)

Natural Stone

Torx Bit 3/16" Fastener (Minimum 1" embedment Depth)

### WARNING:

#### AVOID BREATHING SILICA DUST

This product contains silica. Installation of this product will create silica dusts. Inhalation of silica dust can cause silicosis, a potentially deadly lung disease, and is known to the State of California to cause lung cancer. When drilling, cutting or abrading product during installation or handling: (1) Work outdoors where feasible, otherwise use mechanical ventilation, (2) Wear a dust mask, or if dust may exceed PEL, use NIOSH approved respirator, (3) Warn others in the area. For further information, refer to material safety data sheet or consult employer. This has been prepared to meet current Federal OSHA hazard communication regulations, and is offered without any warranty or guarantee of any type. Castia Stone cannot control the use of its products, and therefore specifically disclaims liability and responsibility arising from the use, misuse and alteration of its products.

# Sketches & Notes

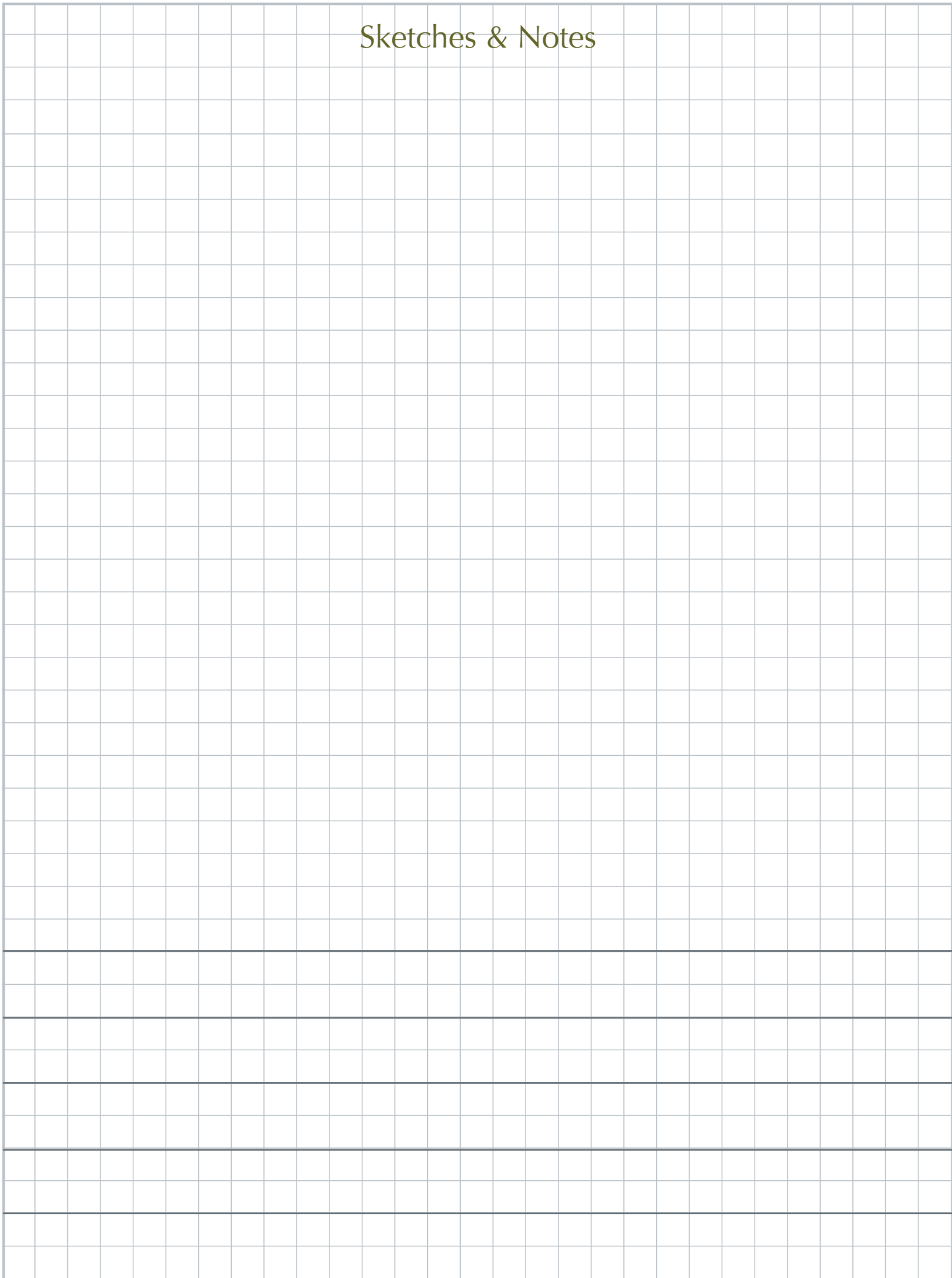



**WWW.CASTIASTONE.COM**

**INFO@CASTIASTONE.COM**

**DOWNLOAD THIS INSTALLATION MANUAL BY SCANNING  
THE QR CODE BELOW WITH YOUR SMART PHONE**

