

HOHMANN & BARNARD, INC.
a MiTek company

Dovetail Anchors, Slots & Ties

305 - Dovetail Slot

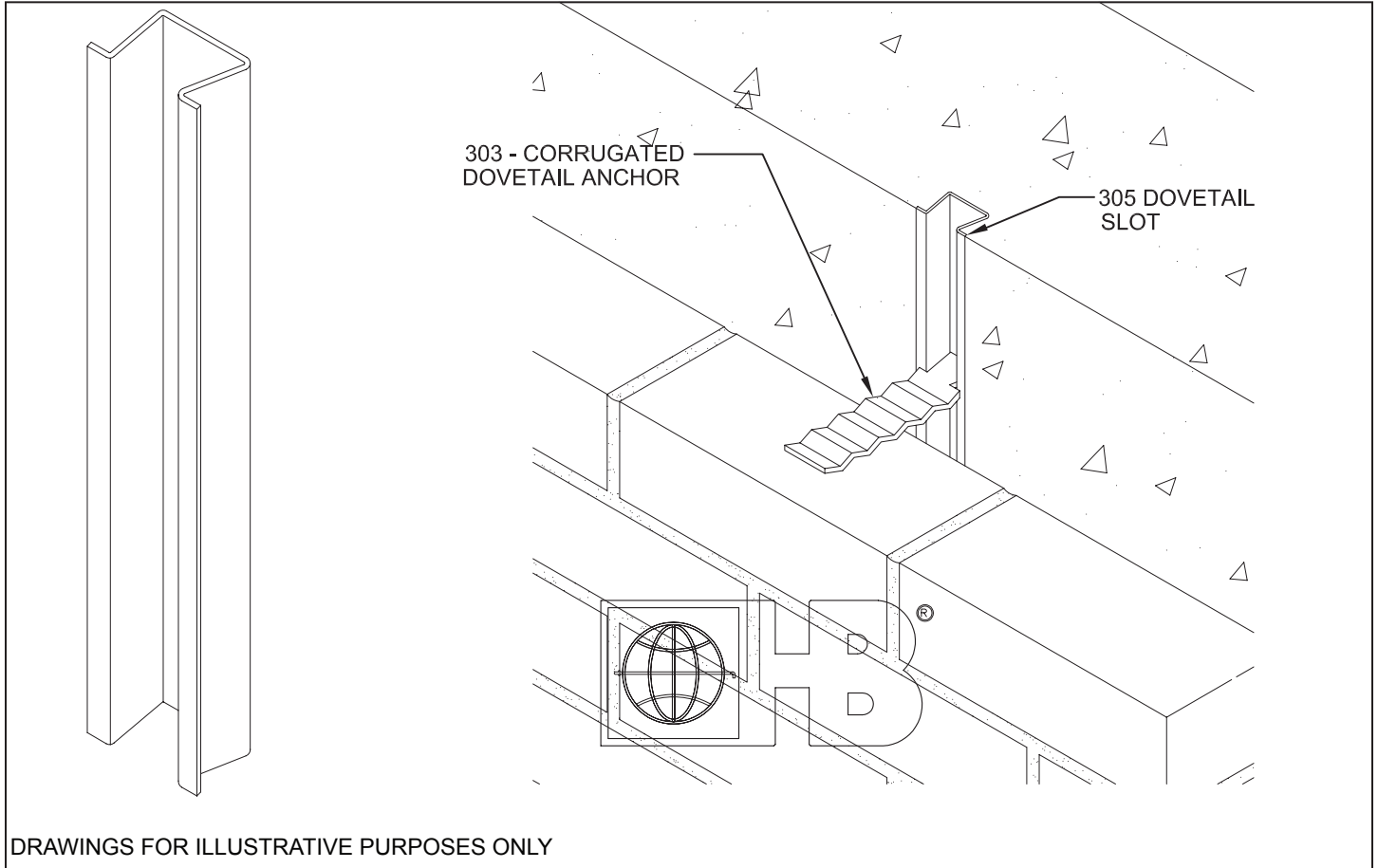

DRAWINGS FOR ILLUSTRATIVE PURPOSES ONLY

305 - Dovetail Slot accepts all H&B dovetail anchors

MATERIAL CONFORMANCE

Sheet Metal (Carbon Steel):

ASTM A1008/A1008M

Zinc Coating:

Mill Galvanized: ASTM A653/A653M Class G60 (0.6 oz/ft²)

Hot-Dip Galvanized after fabrication: ASTM A153/A153M Class B

Note: Hohmann & Barnard will certify Hot-Dip Galvanized to a minimum of 2.0 oz/ft²

Sheet Metal (Stainless Steel):

ASTM A666, ASTM A480/480M, and ASTM A240/A240M

AISI Type 304 or 316

Hohmann & Barnard is not responsible for incompatibility if ties or slots are interchanged with those of other manufacturers.

#305 Dovetail

Slot Thickness: Slots are 10 ft lengths, foam filled.

- 24 Gauge
- 22 Gauge
- 20 Gauge
- 18 Gauge
- 16 Gauge

Finish:

- Mill Galvanized
- Hot-Dip Galvanized (not available for 24 ga.)
- Stainless Steel - Type 304
- Stainless Steel - Type 316 (available on special order)

Note: Hohmann & Barnard recommends Stainless Steel for maximum protection against corrosion.

IMPORTANT: Since each construction project is unique, the appropriate selection and use of any product contained herein must be determined by competent architects, engineers and other appropriate professionals who are familiar with the specific requirements of the project in question.

HOHMANN & BARNARD, Inc.
30 Rasons Court | Hauppauge, NY 11788
CORPORATE HEADQUARTERS
T: 800.645.0616 F: 631.234.0683
www.h-b.com

Branch/Subsidiary Locations:
ALABAMA - ILLINOIS - MARYLAND
NEW YORK - PENNSYLVANIA - TEXAS
UTAH - CANADA

© HOHMANN & BARNARD, INC. - 2015