

HOHMANN & BARNARD, INC.
a MiTek company

Flashing and Reglets Drip Plate

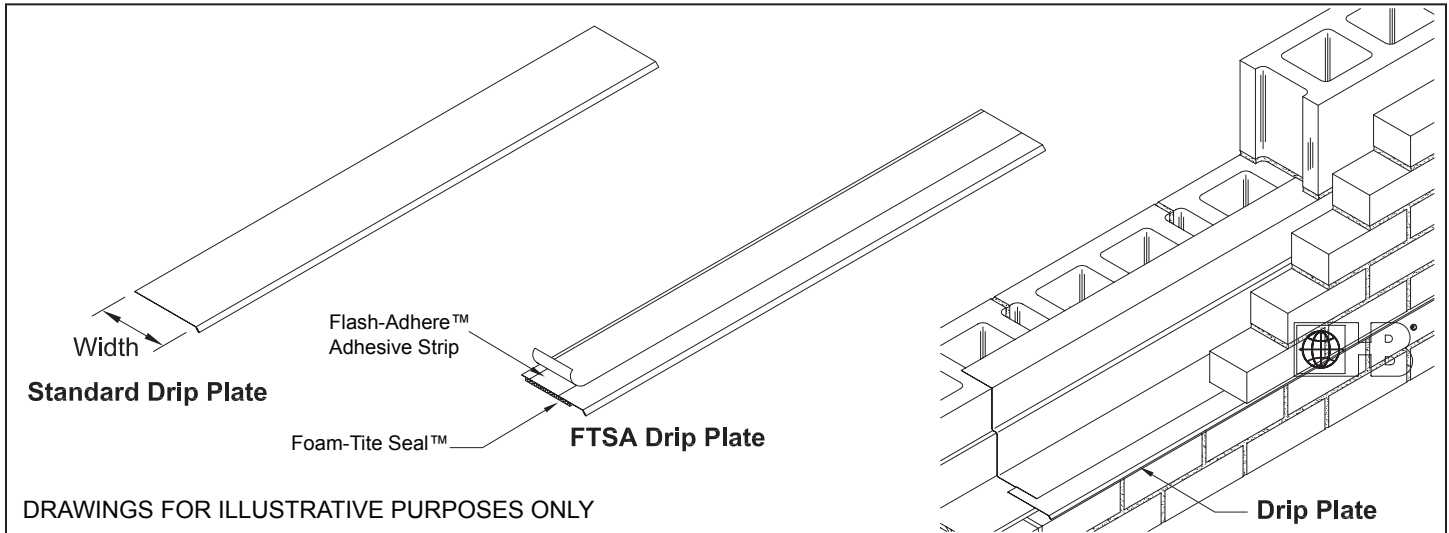

DRAWINGS FOR ILLUSTRATIVE PURPOSES ONLY

Material Conformance:

Stainless Steel Type 304 & 316:
ASTM A240/A240M, ASTM A666,
ASTM A480/A480M, and ASTM A167

Copper: ASTM B370 - #110 Alloy
Lead-Coated Copper:
ASTM B370 - #110 Alloy

- DP** Our Standard Drip Plate, furnished with a smooth, factory-formed hemmed edge for installation safety and uniform appearance. **Standard DP Drip Plates** are compatible with all H&B flashing products.
- DP-LB** Same as above, for lip brick conditions.
- FTS** Optional **Foam-Tite Seal™** offers unique added protection against the ingress of water in cavity wall construction. It is a continuous 1/8" thick strip of factory-installed compressible foam to act as a bond-break and help prevent air and moisture infiltration.
- FTS-LB** Same as above, for lip brick conditions.
- FTSA** Adds our optional **Flash-Adhere™ Adhesive Strip*** to the FTS Drip Plate (as described above). This adhesive strip (with tear-off release paper) is factory-installed on the top side of the drip plate to aid in the precise and permanent placement of the flashing.
- FTSA-LB** Same as above, for lip brick conditions.

NOTE:

- For corner pieces, reference "inside" or "outside" with above product numbers.
- H&B does **NOT** recommend galvanized sheet as a drip plate/edge.

* **When cleaning the exterior veneer, the cleaner's manufacturer recommendations for protecting metal MUST be followed.**

U.S. Pat. No. 6,584,746 Other Patents Pending

Installation Instructions:

DP Series Drip Plates: Install onto a continuous bead of Enviro-Barrier Mastic or H&B approved sealant. ALL laps must be 4" min. with a bead of sealant between and tooled bead of sealant on top of the edges of the overlap.

FTS Series Drip Plates: Must be overlapped 4" min. with a bead of sealant between and tooled bead of sealant on top of the edges of the overlap. (NOTE: 2" of foam must be removed from each side at laps)

- DP - Standard Drip Plate
- DP-LB - Standard Drip Plate (Lip Brick)
- DP-FTS - Drip Plate with Foam-Tite Seal™*
- DP-FTS-LB - Drip Plate with Foam-Tite Seal™(Lip Brick)*
- DP-FTSA - Drip Plate with Foam-Tite Seal™** and Flash-Adhere™ Adhesive Strip**
- DP-FTSA-LB - Drip Plate with Foam-Tite Seal™** and Flash-Adhere™ Adhesive Strip* (Lip Brick)**

* **FTS (Foam-Tite Seal™)** state width of foam _____

** **Flash-Adhere™ Adhesive Strip** is NOT suitable for use with PVC or asphaltic flashing products. Works with all non-asphaltic H&B and Sandell flashing products

Optional Corner Pieces:

- Inside Outside End Dam

Width:

- 1 1/2" 2" 2 1/2"
- 3" 3 1/2" Other _____

Material:

- Type 304 Stainless Steel (26 gauge standard)
- Type 304 Stainless Steel _____ gauge (enter custom gauge)
- Type 316 Stainless Steel (26 gauge standard)
- Type 316 Stainless Steel _____ gauge (enter custom gauge)
- Copper 20 oz. Copper 16 oz. Copper 12 oz.
- Lead-Coated Copper 16 oz Lead-Coated Copper 12 ounce

IMPORTANT: Since each construction project is unique, the appropriate selection and use of any product contained herein must be determined by competent architects, engineers and other appropriate professionals who are familiar with the specific requirements of the project in question.

HOHMANN & BARNARD, Inc.
30 Rasons Court | Hauppauge, NY 11788
CORPORATE HEADQUARTERS
T: 800.645.0616 F: 631.234.0683
www.h-b.com

Branch/Subsidiary Locations:
ALABAMA - ILLINOIS - MARYLAND
NEW YORK - PENNSYLVANIA - TEXAS
UTAH - CANADA

© HOHMANN & BARNARD, INC. - 2015