

HOHMANN & BARNARD, INC.
a MiTek company

High Strength Systems: Veneer Anchor

HB-213-HS with Mighty-Lok™ Hook

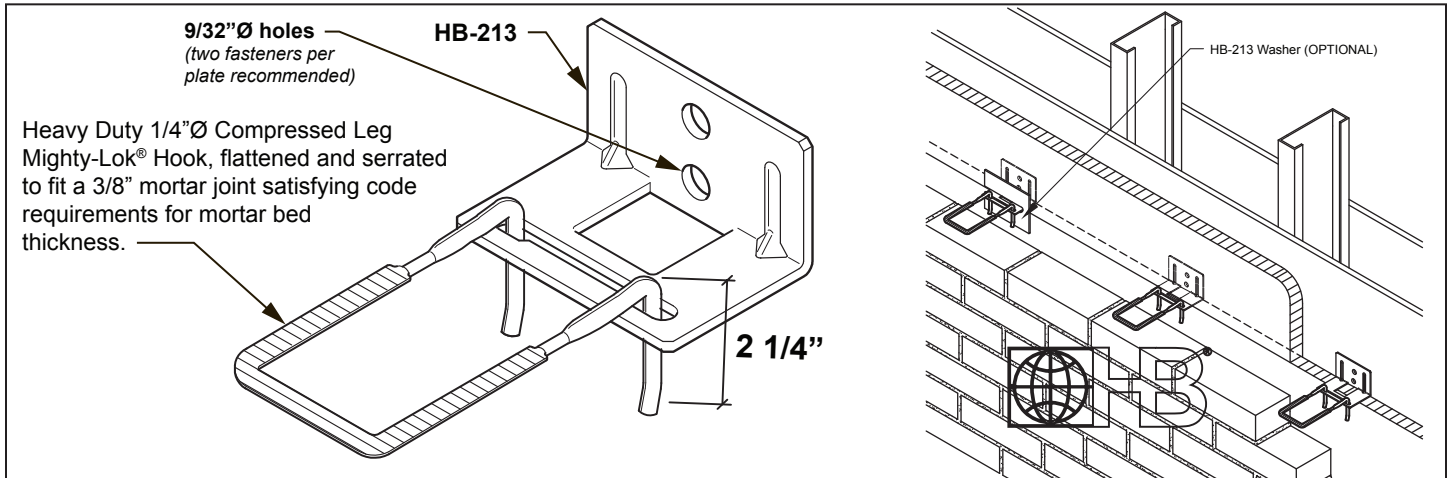

Hohmann & Barnard's Mighty-Lok Hook has been tested and designed to withstand over 290-lbf, in tension or compression, at maximum allowed offset (TMS 402/ACI 530 6.2.2.5.5.4) of 1/4" (disengagement of the pintle from the veneer anchor). These results exceed BIA recommendations and the capabilities of standard "round wire" hooks/pintles by over 100%, while maintaining the ASTM A1064/1064M wire specification.

HB-213 WITH MIGHTY-LOK HOOKS (WORKING LOAD*)

CAVITY	0" OFFSET		1 1/4" OFFSET		2 1/4" OFFSET		TEST
	14 GA	12 GA	14 GA	12 GA	14 GA	12 GA	
4 1/2"	630#	1051#	317#	325#	202#	223#	TENSION
4 1/2"	914#	1026#	293#	290#	191#	196#	COMPRESSION
7 1/2"	546#	921#	317#	331#	206#	217#	TENSION
7 1/2"	608#	920#	294#	270#	186#	192#	COMPRESSION

* WORKING LOAD DETERMINED AT .05" DEFLECTION
Tests were completed for 3" and 6" insulation with 1 1/2" air cavity.

DRAWINGS FOR ILLUSTRATIVE PURPOSES ONLY

H&B RECOMMENDS 16" X 16" SPACING

MATERIAL CONFORMANCE

Wire (Carbon Steel):

Cold-drawn steel wire conforming to **ASTM A1064/A1064M**:

Tensile Strength - 80,000 psi | Yield Point - 70,000 psi minimum

Zinc Coating:

Hot-Dip Galvanized after fabrication: **ASTM A153/A153M-B2** (1.5 oz/ft²)

Wire (Stainless Steel):

ASTM A580/A580M - AISI Type 304 & Type 316

H&B manufactures steel wire products from a minimum of 95% post-consumer recycled material.

Sheet Metal (Carbon Steel): **ASTM A1008/A1008M**

Zinc Coating: Hot-Dip Galvanized: (refer to wire above)

Sheet Metal (Stainless Steel):

ASTM A 666, ASTM A480/480M, and ASTM A240/A240M

AISI Type 304 or 316

U.S. Pat. No. 8,122,663 (Mighty-Lok Hook)

NOTES:

- State overall wall size & cavity or insulation thickness when ordering
- Two fasteners per plate recommended
- Needs 3/4 inch (19mm) to 1 inch (25mm) minimum air cavity
- For attachment to concrete, block or brick see 523 Brass Expansion Bolt

HB-213 Anchor Backplate Finish:

Hot-Dip Galvanized

Stainless Steel - Type 304 Stainless Steel - Type 316

H&B recommends Stainless Steel for maximum protection against corrosion

HB-213 Backplate (Equal to thickness of insulation):

0" 1" 1 1/2" 2" 2 1/2" 3" 3 1/2"

4" 4 1/2" 5" 5 1/2" 6"

Backplate Thickness:

12 ga. (2.7 mm) 11 ga. (3.1 mm) CUSTOM _____

1/4"Ø Mighty Lok® Hook Length:

3" 4" 4 1/4"

5 1/4" Custom _____

Optional: HB-213 Washer to hold insulation to back-up

IMPORTANT: Since each construction project is unique, the appropriate selection and use of any product contained herein must be determined by competent architects, engineers and other appropriate professionals who are familiar with the specific requirements of the project in question.

HOHMANN & BARNARD, Inc.
CORPORATE HEADQUARTERS
30 Rasons Court | Hauppauge, NY 11788
T: 800.645.0616 F: 631.234.0683
www.h-b.com

Branch/Subsidiary Locations:
ALABAMA - ILLINOIS - MARYLAND
NEW YORK - PENNSYLVANIA - TEXAS
UTAH - CANADA

© HOHMANN & BARNARD, INC. - 2015