

Seismic Anchors and Ties

315-BL

Byna-Lok™ Flexible Dovetail

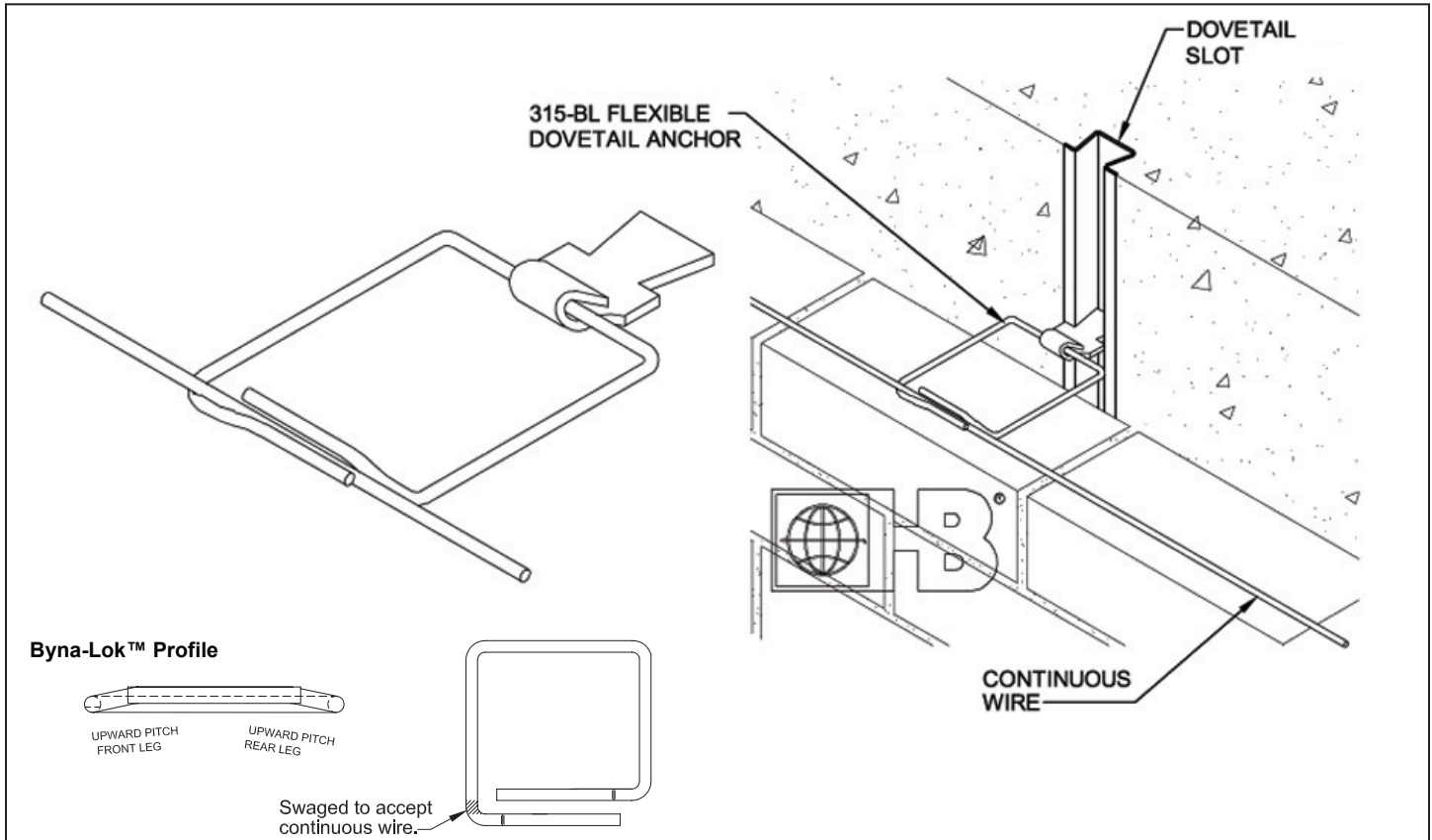

DRAWINGS FOR ILLUSTRATIVE PURPOSES ONLY

315-BL Byna-Lok™ permits horizontal and vertical movement of the masonry wall, while restraining tension and compression

MATERIAL CONFORMANCE

Wire (Carbon Steel): Prefabricated from cold-drawn steel wire conforming to **ASTM A1064/A1064M**

Tensile Strength - 80,000 psi | Yield Point - 70,000 psi minimum

Zinc Coating:

Hot-Dip Galvanized after fabrication: **ASTM A153/A153M-B** (1.5 oz/ft²)

Note: Hohmann & Barnard will certify to a minimum of 2.0 oz/ft²

Wire (Stainless Steel):

ASTM A580/A580M - AISI Type 304 (Type 316 available on special order)

Sheet Metal (Carbon Steel):

ASTM A1008/A1008M

Zinc Coating:

Hot-Dip Galvanized: **ASTM A153/A153M Class B** (1.5 oz/ft²)

(sheet metal ties and anchors galvanized after fabrication)

Note: Hohmann & Barnard will certify to a minimum of 2.0 oz/ft²

Sheet Metal (Stainless Steel):

ASTM A666, ASTM A480/480M, and ASTM A240/A240M - AISI Type 304 or Type 316

H&B manufactures steel wire products from a minimum of 95% post-consumer recycled material.

Finish:

Hot-Dip Galv. | Stainless Steel: Type 304 Type 316

Note: Hohmann & Barnard recommends Stainless Steel for maximum protection against corrosion.

Dovetail Head:

14 gauge (Standard) 12 gauge (Heavyweight)

Byna-Lok™ Length: 3/16"Ø x

3" 4" 5" Other _____

System includes heavy-duty continuous wire.

315-BL is made to fit with 305 Dovetail Slot. Hohmann & Barnard is not responsible for incompatibility if ties or slots are interchanged with those of other manufacturers.

IMPORTANT: Since each construction project is unique, the appropriate selection and use of any product contained herein must be determined by competent architects, engineers and other appropriate professionals who are familiar with the specific requirements of the project in question.