

Ties & Anchors - Miscellaneous

345-BT Flexible Tie

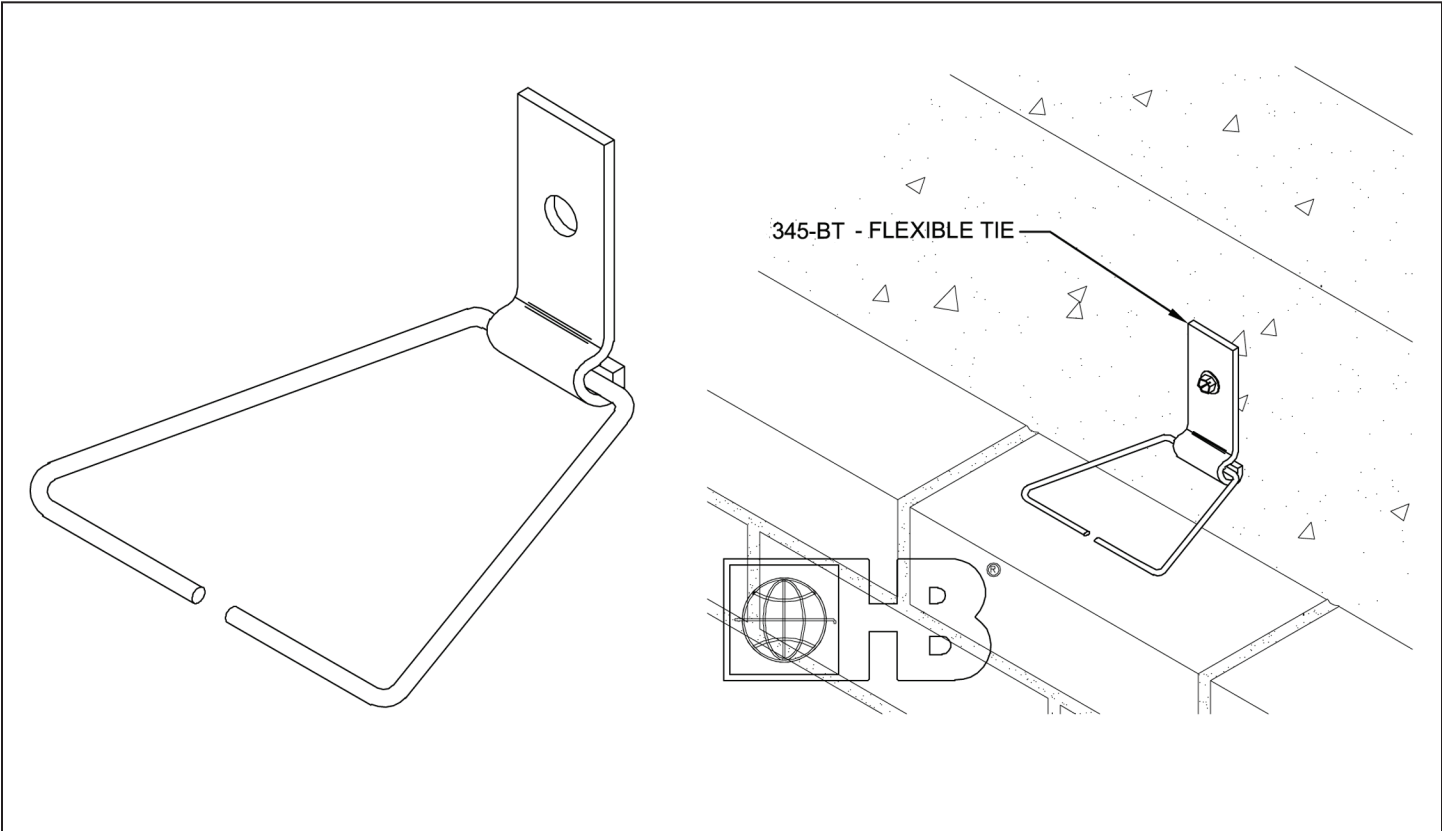

DRAWINGS FOR ILLUSTRATIVE PURPOSES ONLY

345-BT Flexible Tie, Vee Byna-Tie® with a wrap-around metal strap for tying masonry to concrete or CMU backup with a flexible connection.

MATERIAL CONFORMANCE

Wire (Carbon Steel): Prefabricated from cold-drawn steel wire conforming to **ASTM A1064/A1064M**

Tensile Strength - 80,000 p.s.i. | Yield Point - 70,000 p.s.i. minimum
Zinc Coating:

Mill Galvanized coating: **ASTM A641/A641M** (0.1 oz/ft²)

Hot-Dip Galvanized: **ASTM A153/A153M Class B** (1.5 oz/ft²) (sheet metal ties and anchors galvanized after fabrication)

Note: Hohmann & Barnard will certify to a minimum of 2.0 oz/ft²

Wire (Stainless Steel):

ASTM A580/A580M - AISI Type 304 (Type 316 available on special order)

Sheet Metal (Carbon Steel):

ASTM A1008/A1008M

Zinc Coating:

Mill Galvanized: **ASTM A653/A653M Class G60** (0.6 oz/ft²)

Hot-Dip Galvanized: (refer to wire above)

Note: Hohmann & Barnard will certify to a minimum of 2.0 oz/ft²

Sheet Metal (Stainless Steel):

ASTM A666, ASTM A480/480M, and ASTM A240/A240M

AISI Type 304 or 316

Finishes:

Mill Galvanized

Hot-Dip Galv. | Stainless Steel: Type 304 Type 316

Note: Hohmann & Barnard recommends Stainless Steel for maximum protection against corrosion.

Flexible Head Thickness: (3/4" wide with a 5/16" hole)

12 gauge (heavyweight)

Vee Byna-Tie® Length:

3"

3 1/2"

4"

4 1/2"

5"

6"

7"

Other _____

Vee Byna-Tie® Diameter

3/16"Ø (standard)

1/4"Ø (heavyweight)

Vee Byna-Tie component manufactured from a minimum of 95% post-consumer recycled material.

IMPORTANT: Since each construction project is unique, the appropriate selection and use of any product contained herein must be determined by competent architects, engineers and other appropriate professionals who are familiar with the specific requirements of the project in question.

HOHMANN & BARNARD, Inc.

30 Rasons Court | Hauppauge, NY 11788
CORPORATE HEADQUARTERS

T: 800.645.0616 F: 631.234.0683

www.h-b.com

Branch/Subsidiary Locations:

ALABAMA - ILLINOIS - MARYLAND

NEW YORK - PENNSYLVANIA - TEXAS

UTAH - CANADA

© HOHMANN & BARNARD, INC. - 2015