

# Veneer Anchors

## Thermal Concrete 2-Seal™ Tie

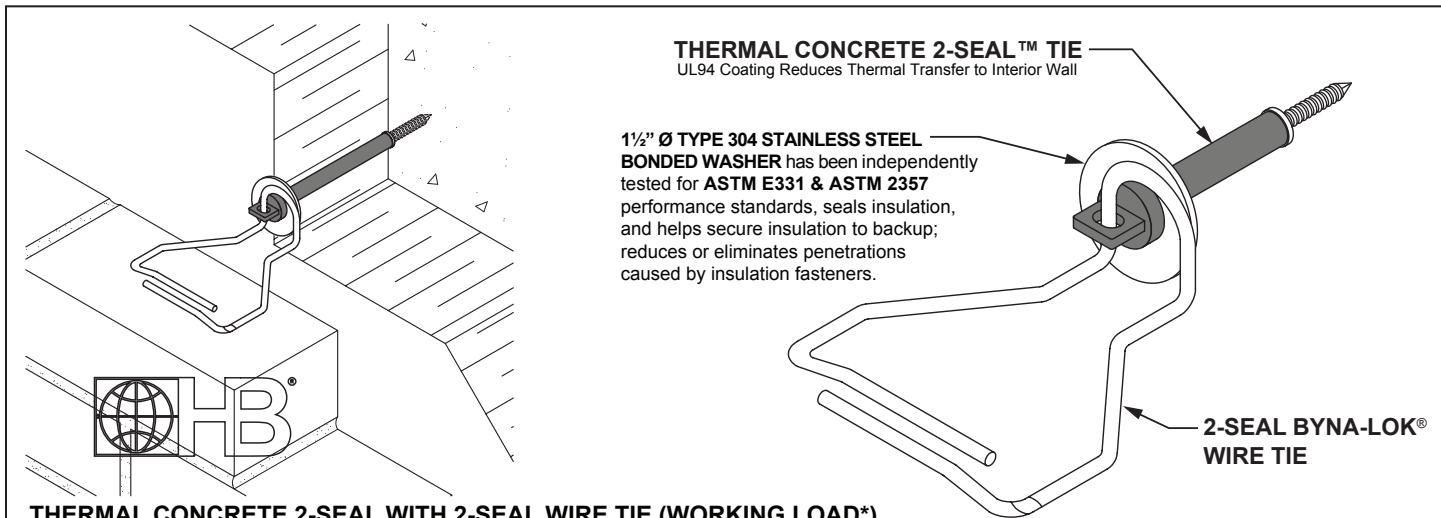

**THERMAL CONCRETE 2-SEAL™ TIE**  
UL94 Coating Reduces Thermal Transfer to Interior Wall

1 1/2" Ø TYPE 304 STAINLESS STEEL BONDED WASHER has been independently tested for ASTM E331 & ASTM 2357 performance standards, seals insulation, and helps secure insulation to backup; reduces or eliminates penetrations caused by insulation fasteners.

**2-SEAL BYNA-LOK® WIRE TIE**

**THERMAL CONCRETE 2-SEAL WITH 2-SEAL WIRE TIE (WORKING LOAD\*)**

CAVITY	0" OFFSET	5/8" OFFSET	1 1/4" OFFSET	TEST
6 1/2"	573#	N/A	206#	TENSION
6 1/2"	402#	N/A	166#	COMPRESSION

\* WORKING LOAD DETERMINED AT .05" DEFLECTION

Tests were completed for 4 1/2" insulation with 2" air cavity.

Pullout values assume wire 2-Seal Byna-Lok Wire Tie is fully engaged into 2-Seal Tie with "0" eccentricity.

**SCREW PULL-OUT (1 1/4" minimum embed)**

CONCRETE	C-90 Hollow Block
810# (average ultimate load)	700# (average ultimate load)

DRAWINGS FOR ILLUSTRATIVE PURPOSES ONLY

**H&B RECOMMENDS 16" X 16" SPACING**

**Thermal Concrete 2-Seal™ Tie** is an innovative single screw veneer tie suitable for use with concrete, CMU, wood stud or brick backup.

The anchor is **FULLY COATED** with a proprietary material tested in accordance to **UL94 (The Standard for Flammability of Plastic Materials)**. The material reduces thermal transfer through rigid insulation.

- #14 screw with alternating threads and two factory-installed EPDM sealing washers
- Available for 5/8" - 4 1/2" wallboard + insulation combination

The 2-Seal Byna-Lok Wire Tie is adaptable for seismic zones with the simple addition of 9 gauge or 3/16" continuous wire (just drop into the integral track formed by the swaged, overlapping legs of the wire tie.)

**Barrel (Stainless Steel): ASTM A580/A580M - AISI Type 304**

**Screw (Carbon Steel): ASTM A510 (Carbon Steel)**

**ASTM C954 (1000-hour polymer coating)**

**Coating: ASTM D792 (density), ASTM D785 (Hardness),**

**ASTM D955 (Mould Shrinkage), ASTM D638 (Tensile Strength),**

**ASTM D790 (Flexural Strength), ASTM D256 (Izod Impact**

**Strength), ASTM D1525 (Softening Temp) ASTM D648 (Heat**

**Distortion Temp.), UL94 (Flammability)**

**Wire (Carbon Steel):** Prefabricated from cold-drawn steel wire conforming to **ASTM A1064/A1064M**

Tensile Strength - 80,000 p.s.i. | Yield Point - 70,000 p.s.i. minimum

Zinc Coating:

Hot-Dip Galvanized after fabrication: **ASTM A153/A153M-B (1.5 oz/ft<sup>2</sup>)**

**Wire (Stainless Steel): ASTM A580/A580M - AISI Type 304 or Type 316**

**U.S. Patent No. 8,037,653 & 9,140,001 | Canadian Patent No. 2,690,819**  
**OTHER PATENTS PENDING**

**Barrel Finish (Screw is Polymer Coated Steel):**

Type 304 Stainless Steel Barrel

**Thermal Concrete Tie Size (Equal to thickness of insulation):**

- |                                 |                                 |                                 |
|---------------------------------|---------------------------------|---------------------------------|
| <input type="checkbox"/> 5/8"   | <input type="checkbox"/> 2"     | <input type="checkbox"/> 3 1/2" |
| <input type="checkbox"/> 1"     | <input type="checkbox"/> 2 1/2" | <input type="checkbox"/> 4"     |
| <input type="checkbox"/> 1 1/2" | <input type="checkbox"/> 3"     | <input type="checkbox"/> 4 1/2" |

**2-Seal Byna-Lok™ Wire Tie Finish:**

Hot-Dip Galvanized | Stainless Steel  Type 304  Type 316

**2-Seal Byna-Lok™ Wire Tie Length: (3/16"Ø)**

3"  4"  5"  Custom \_\_\_\_\_

**Continuous Wire Finish:**

Hot-Dip Galvanized | Stainless Steel  Type 304  Type 316

**Continuous Wire Diameter:**  9 gauge  3/16"Ø

**Note:** Hohmann & Barnard recommends **Stainless Steel for maximum protection against corrosion.**

**IMPORTANT:** Since each construction project is unique, the appropriate selection and use of any product contained herein must be determined by competent architects, engineers and other appropriate professionals who are familiar with the specific requirements of the project in question.