

Veneer Anchors

2-Seal™ Tie

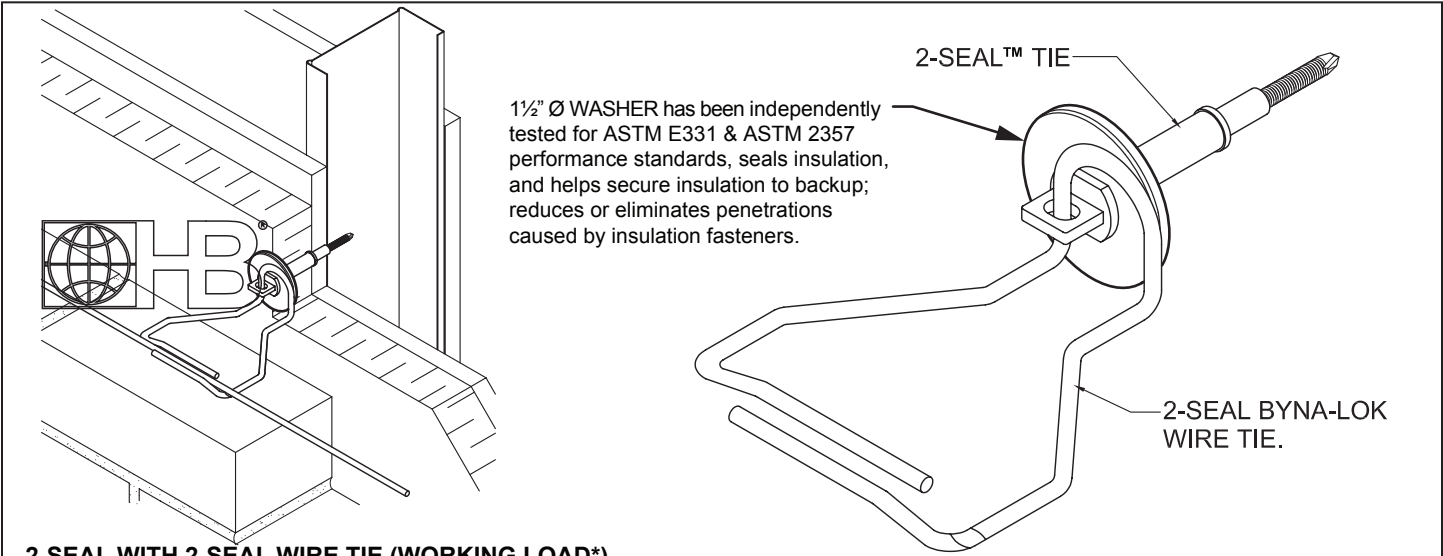

1 1/2" Ø WASHER has been independently tested for ASTM E331 & ASTM 2357 performance standards, seals insulation, and helps secure insulation to backup; reduces or eliminates penetrations caused by insulation fasteners.

2-SEAL™ TIE

2-SEAL BYNA-LOK WIRE TIE.

2-SEAL WITH 2-SEAL WIRE TIE (WORKING LOAD*)

CAVITY	0" OFFSET	5/8" OFFSET	1 1/4" OFFSET	TEST
6 1/2"	573#	N/A	206#	TENSION
6 1/2"	402#	N/A	166#	COMPRESSION

* WORKING LOAD DETERMINED AT .05" DEFLECTION

Tests were completed for 4 1/2" insulation with 2" air cavity.

Pullout values assume wire 2-Seal Byna-Lok Wire Tie is fully engaged into 2-Seal Tie with "0" eccentricity.

SCREW PULL-OUT (ULTIMATE LOAD)

STUD GA	18 GA	16 GA	14 GA	12 GA
	611#	743#	1096#	1394#

DRAWINGS FOR ILLUSTRATIVE PURPOSES ONLY

H&B RECOMMENDS 16" X 16" SPACING

2-Seal™ Tie

An innovative single screw veneer tie for metal stud construction. The 2-Seal™ Tie has a dual-diameter barrel with factory-installed EPDM washers to seal both the face of the insulation and the air/vapor barrier.

- #12 screw integrated into the dual-diameter barrel
- Available for 5/8" - 4 1/2" wallboard + insulation combination

The 2-Seal Byna-Lok Wire Tie is adaptable for seismic zones with the simple addition of 9 gauge or 3/16" continuous wire (just drop into the integral track formed by the swaged, overlapping legs of the wire tie.)

Barrel (Zamac Zinc): **ASTM B86** (92% Zinc Alloy) with protective polymer coating for corrosion resistance

Screw (Carbon Steel): **ASTM A510** (Carbon Steel)
ASTM C954 (1000-hour polymer coating)

Wire (Carbon Steel): Prefabricated from cold-drawn steel wire conforming to **ASTM A1064/A1064M**
Tensile Strength - 80,000 p.s.i. | Yield Point - 70,000 p.s.i. minimum Zinc Coating:
Hot-Dip Galvanized after fabrication: **ASTM A153/A153M-B** (1.5 oz/ft²)

Wire (Stainless Steel): **ASTM A580/A580M** - AISI Type 304 or Type 316

U.S. Patent No. 8,037,653
Canadian Patent No. 2,690,819

2-Seal™ Tie Finish*:

- Polymer Coated
*For Stainless Steel, refer to Thermal 2-Seal Wing Nut Anchor.

2-Seal™ Tie Style (Equal to thickness of wallboard + insulation):

- 5/8" 1" 1 1/2" 2" 2 1/2" 3" 3 1/2"
 4" 4 1/2"

2-Seal Byna-Lok™ Wire Tie Finish:

- Hot-Dip Galvanized | Stainless Steel Type 304 Type 316

2-Seal Byna-Lok™ Wire Tie Length: (3/16"Ø)

- 3" 4" 5" Custom _____

Continuous Wire Finish:

- Hot-Dip Galvanized | Stainless Steel Type 304 Type 316

Continuous Wire Diameter: 9 gauge 3/16"Ø

Note: Hohmann & Barnard recommends Stainless Steel for maximum protection against corrosion.

IMPORTANT: Since each construction project is unique, the appropriate selection and use of any product contained herein must be determined by competent architects, engineers and other appropriate professionals who are familiar with the specific requirements of the project in question.