

SMALL PLANTERS

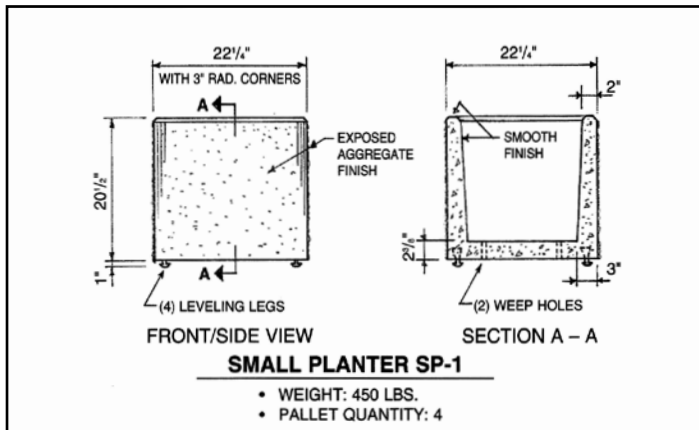

SMALL PLANTER SP-1
EXPOSED AGGREGATE #1 FINISH

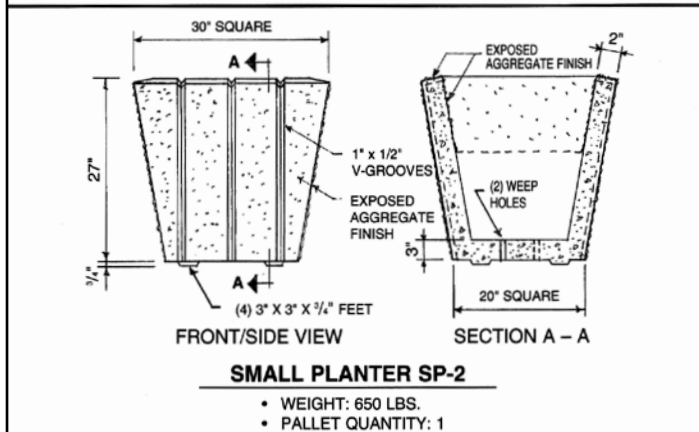

SMALL PLANTER SP-2
EXPOSED AGGREGATE #1 FINISH

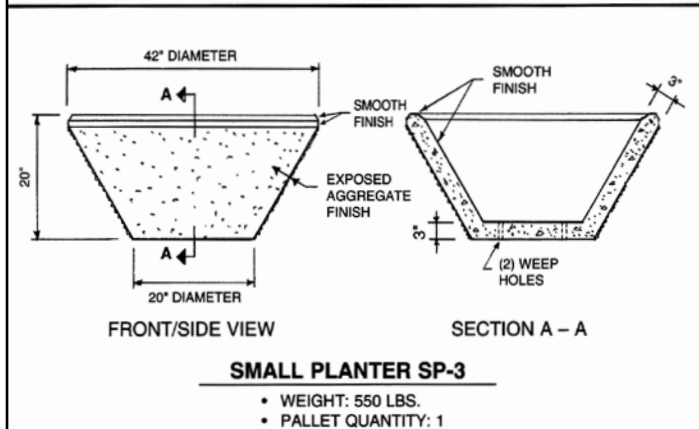

SMALL PLANTER SP-3
EXPOSED AGGREGATE #1 FINISH

BASIC USES AND FEATURES

- For exterior and interior locations at commercial and business facilities, schools and streetscapes.
- Attractive units with maximum resistance to weather and vandalism.
- Weep holes of interior units must be sealed watertight.

COMPOSITION & MATERIALS

- Concrete: Air entrained, achieving 5000 PSI compressive strength in 28 days.
- Reinforcing: Steel rebars each unit.

AVAILABLE FINISHES

- Exposed Aggregate #1, Gray crushed limestone, 3/8" top size.
- Exposed Aggregate #2, Pea gravel, 1/2" top size.
- Light Sandblast Texture, natural concrete color.