

# TECH-GUIDE



PAVERS | RETAINING WALLS | ACCESSORIES



# DURA DENZ PRODUCTS AVAILABLE

## POLYMERIC SAND

Our Dura Denz Polymeric Sand will minimize sand erosion from pavement joints, deters weed growth, insect infestation and reduces overall pavement maintenance. **Dura Denz polymeric sand is available in two colors: Tan & Granite.**

## ALL-IN-ONE SEALER

How do you go about keeping your new paver project looking its absolute best? By sealing it with a Dura Denz All-In-One Penetrating Sealer, uniquely formulated in conjunction with the Americana Collection pavers to enhance, protect, and stabilize your paver project. **Dura Denz penetrating sealers are offered in both Water Based and Solvent Based formulas - Matte and Wet-Look finishes: 1-gallon & 5-gallon sizes.**

## BEST PRACTICES

**We adhere to ICPI System Practices.**

- After excavation, install geosynthetic fabric
- Install sub-base material (open graded 3/4" clean or 3/4" down to fines)
- Install bedding layer (clean limestone chip or concrete sand)
- Install Americana Collection paver
- Sweep in Dura Denz Polymeric Sand
- Clean patio in preparation of sealer
- Seal patio with Dura Denz All-In-One Sealer

Dura Denz is exclusive to Oberfields and represents a dramatic break-through in concrete casting technology. Our Americana Collection line of premium pavers are infused with Dura Denz. A specially formulated dense top layer that creates a smooth, extra-hard surface that resists chipping, scratching and fading. The result is products that are not only beautiful, but extremely durable.

Call your Oberfields representative today.  
**Because quality matters.**

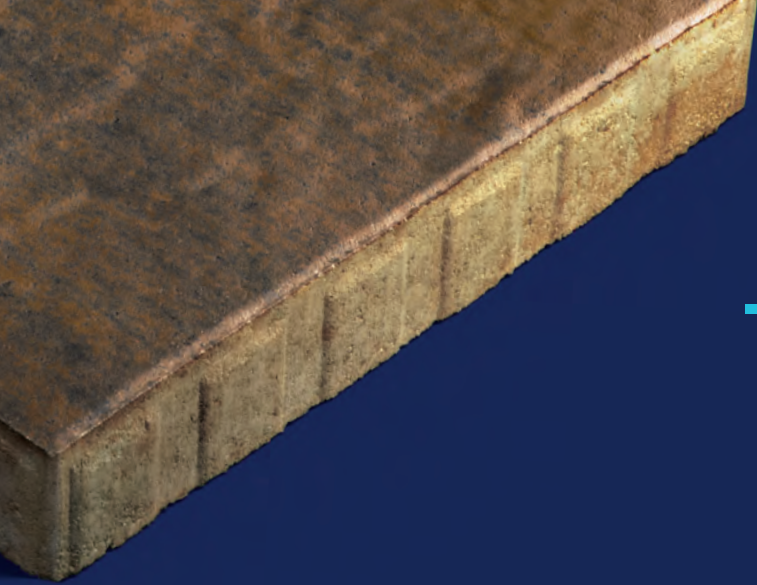

# Contents

SEE AND FEEL THE  
**DIFFERENCE**  
DESIGN TO BE  
**DIFFERENT**



**EXTREMELY DURABLE**  
RESISTS DAILY WEAR AND TEAR



**COLOR FADE RESISTANT**



**EXCEEDS ASTM STANDARDS**  
ENHANCED QUALITY AND STRENGTH



**DENSE TOP-LAYER**  
(NO COARSE AGGREGATE)



**AMERICAN OWNED AND MADE**

## PAVERS

- Lexington® .....4
- Malibu® .....5
- Ozark® .....6
- Manhattan® .....7
- Newport® .....8
- Plymouth® .....9
- Jamestown® .....10
- CityStone™ XL .....11
- Grand Flagstone .....12
- Dimensional Flagstone .....13
- Special Reserve Travertine & Marble .....14
- Natural Stone .....15
- Eco-Elite™ L-10 .....16

## WALLS

- Edington Wall Stone® .....17
- Belvedere Wall .....18
- Dimensional Wall .....19
- Kodah Wall .....20
- Outcropping Wall .....21
- Versa-Lok® .....22
- RegalStone Pro® .....23
- MagnumStone® .....24

## STAIR TREADS | WALL COPINGS

- Bullnose .....25
- Olentangy Bluff Tread™ .....26
- Dimensional and Irregular Steps .....27
- Superior Steppers .....28
- Dimensional Coping .....29

## KITS | PATTERNS | WARRANTY

- Edington® Fire Pit Kit .....30
- Belvedere® Fire Pit Kit .....31
- Dimensional Fire Pit Kit .....32
- Kodah Fire Pit Kit .....33
- Edington® Pub Table Kit .....34
- Paver Patterns .....35
- Warranty .....39

# Lexington®



**Lexington 10**  
4 1/8" x 5 1/2" x 2 3/8"



**Lexington 14**  
5 1/2" x 5 1/2" x 2 3/8"



**Lexington 21**  
5 1/2" x 8 1/4" x 2 3/8"

## INSTALLATION PATTERNS

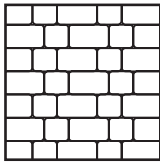

Muster D  
40% Lexington 14  
60% Lexington 21

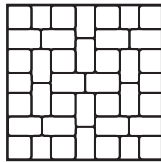

Muster K  
28% Lexington 14  
72% Lexington 21

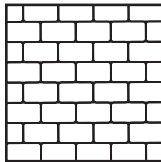

Running Bond  
10, 14, or 21

## APPLICATIONS

Pedestrian traffic, residential driveways, patios, borders and swimming pool decks. Vehicular-Rated.

## PACKAGING INFO

PRODUCT	WEIGHT PER SQ. FT.	UNITS PER SQ. FT.	SQ. FT. PER UNIT	UNITS PER LAYER	LAYERS PER CUBE	SQ. FT. PER LAYER	UNITS PER CUBE	WEIGHT PER CUBE	TOTAL SQ. FT. PER CUBE	COLORS STOCKED
Lexington® 10	29 lbs	6.34	0.16	72	9	11.36	648	2965 lbs	102	Charcoal
Lexington® 14	29 lbs	4.76	0.21	56	9	11.76	504	3069 lbs	106	Canyon Creek, Charcoal, Driftwood, Earth, Flagstone, Granite, Storm
Lexington® 21	29 lbs	3.17	0.32	42	8	13.25	336	3074 lbs	106	Canyon Creek, Charcoal, Driftwood, Earth, Flagstone, Granite, Storm



Due to variations in printing, color selections should always be chosen from actual product samples. Americana Collection pavers require a buffer between the plate compactor and the paver surface to prevent scuffing.

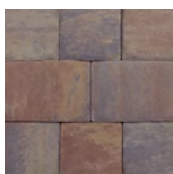

Canyon Creek

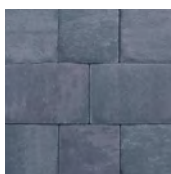

Charcoal



Driftwood

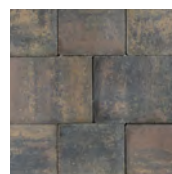

Earth

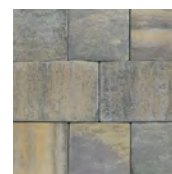

Flagstone



Granite

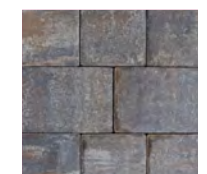

Storm



# Malibu®



PAVERS

AMERICANA COLLECTION

Packaged Together

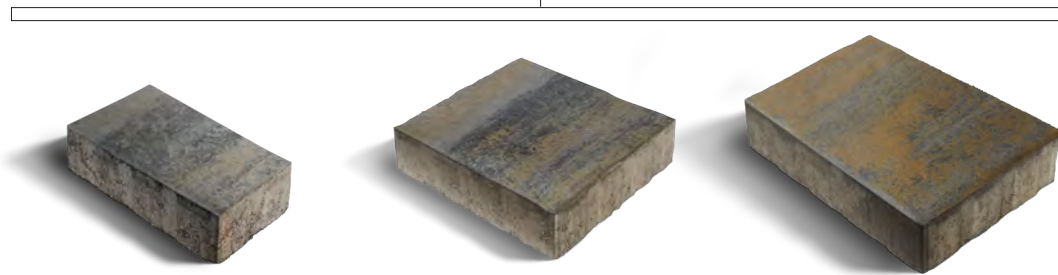

**Malibu Small Rectangle**

4<sup>3</sup>/<sub>4</sub>" x 9<sup>3</sup>/<sub>8</sub>" x 2<sup>3</sup>/<sub>8</sub>"

**Malibu Square**

9<sup>3</sup>/<sub>8</sub>" x 9<sup>3</sup>/<sub>8</sub>" x 2<sup>3</sup>/<sub>8</sub>"

**Malibu Large Rectangle**

9<sup>3</sup>/<sub>8</sub>" x 14<sup>1</sup>/<sub>8</sub>" x 2<sup>3</sup>/<sub>8</sub>"

INSTALLATION PATTERNS

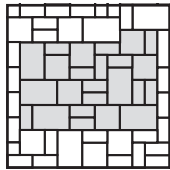

Pattern A

APPLICATIONS

Pedestrian traffic, patios, swimming pool decks, and sidewalks.

PACKAGING INFO

PRODUCT	WEIGHT PER SQ. FT.	UNITS PER SQ. FT.	SQ. FT. PER UNIT	UNITS PER LAYER	LAYERS PER CUBE	SQ. FT. PER LAYER	UNITS PER CUBE	WEIGHT PER CUBE	TOTAL SQ. FT. PER CUBE	COLORS STOCKED
Malibu® Small Rectangle	29 lbs	3.23	0.31	13	8	4.03	104	2851 lbs Combined Weight	98 All Sizes Together	Canyon Creek, Driftwood, Earth, Flagstone, Granite, Storm
Malibu® Square	29 lbs	1.64	0.61	6	8	3.66	48			Canyon Creek, Driftwood, Earth, Flagstone, Granite, Storm
Malibu® Large Rectangle	29 lbs	1.09	0.92	5	8	4.6	40			Canyon Creek, Driftwood, Earth, Flagstone, Granite, Storm



Due to variations in printing, color selections should always be chosen from actual product samples. Americana Collection pavers require a buffer between the plate compactor and the paver surface to prevent scuffing.



Canyon Creek



Driftwood



Earth



Flagstone



Granite



Storm

# Ozark®



Packaged Together

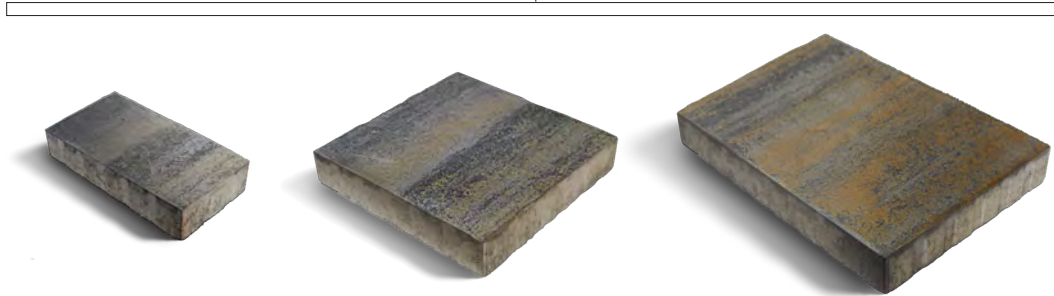

**Ozark Small Rectangle**

7 1/8" x 14 1/8" x 2 3/8"

**Ozark Square**

14 1/8" x 14 1/8" x 2 3/8"

**Ozark Large Rectangle**

14 1/8" x 21 1/4" x 2 3/8"

INSTALLATION PATTERNS

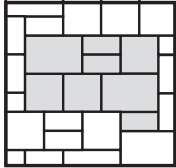

Pattern A

APPLICATIONS

Pedestrian traffic, patios, swimming pool decks, and sidewalks.

PACKAGING INFO

PRODUCT	WEIGHT PER SQ. FT.	UNITS PER SQ. FT.	SQ. FT. PER UNIT	UNITS PER LAYER	LAYERS PER CUBE	SQ. FT. PER LAYER	UNITS PER CUBE	WEIGHT PER CUBE	TOTAL SQ. FT. PER CUBE	COLORS STOCKED
Ozark® Small Rectangle	29 lbs	1.43	0.70	3	10	2.1	30	Combined Weight 3024 lbs	All Sizes Together 104	Driftwood, Earth, Flagstone, Granite, Storm
Ozark® Square	29 lbs	0.72	1.39	3	10	4.17	30			Driftwood, Earth, Flagstone, Granite, Storm
Ozark® Large Rectangle	29 lbs	0.48	2.08	2	10	4.16	20			Driftwood, Earth, Flagstone, Granite, Storm



Due to variations in printing, color selections should always be chosen from actual product samples. Americana Collection pavers require a buffer between the plate compactor and the paver surface to prevent scuffing.



Driftwood



Earth



Flagstone

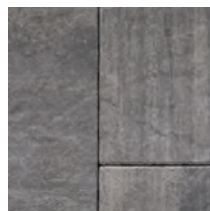

Granite



Storm

# Manhattan®



PAVERS

AMERICANA COLLECTION

Packaged Together



### Manhattan Small Rectangle

7 1/8" x 14 1/8" x 2 3/8"

### Manhattan Square

14 1/8" x 14 1/8" x 2 3/8"

### Manhattan Large Rectangle

14 1/8" x 21 1/4" x 2 3/8"

## INSTALLATION PATTERNS

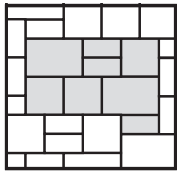

Pattern A

## APPLICATIONS

Pedestrian traffic, patios, swimming pool decks, and sidewalks.

## PACKAGING INFO

PRODUCT	WEIGHT PER SQ. FT.	UNITS PER SQ. FT.	SQ. FT. PER UNIT	UNITS PER LAYER	LAYERS PER CUBE	SQ. FT. PER LAYER	UNITS PER CUBE	WEIGHT PER CUBE	TOTAL SQ. FT. PER CUBE	COLORS STOCKED
Manhattan® Small Rectangle	29 lbs	1.43	0.7	3	10	21	30	Combined Weight 3024 lbs	All Sizes Together 104	Driftwood, Earth, Flagstone, Granite, Storm
Manhattan® Square	29 lbs	0.72	1.39	3	10	4.17	30			
Manhattan® Large Rectangle	29 lbs	0.48	2.08	2	10	4.16	20			



Due to variations in printing, color selections should always be chosen from actual product samples. Americana Collection pavers require a buffer between the plate compactor and the paver surface to prevent scuffing.



Driftwood



Earth



Flagstone



Granite



Storm



# Newport®



Packaged Together



**Newport Small Rectangle**  
 $11 \frac{3}{4}'' \times 17 \frac{3}{4}'' \times 2 \frac{3}{8}''$



**Newport Square**  
 $11 \frac{3}{4}'' \times 11 \frac{3}{4}'' \times 2 \frac{3}{8}''$



**Newport Large Rectangle**  
 $11 \frac{3}{4}'' \times 23 \frac{5}{8}'' \times 2 \frac{3}{8}''$

## APPLICATIONS

Pedestrian traffic, patios, swimming pool deck, and sidewalks.

## INSTALLATION PATTERNS

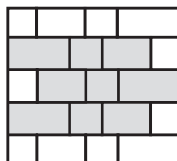

Random Running Bond

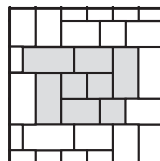

Pattern B

## PACKAGING INFO

PRODUCT	WEIGHT PER SQ. FT.	UNITS PER SQ. FT.	SQ. FT. PER UNIT	UNITS PER LAYER	LAYERS PER CUBE	SQ. FT. PER LAYER	UNITS PER CUBE	WEIGHT PER CUBE	TOTAL SQ. FT. PER CUBE	COLORS STOCKED	
Newport® Small Rectangle	29 lbs	0.69	1.45	2	9	2.9	18	3020 lbs	104	Driftwood, Granite, Storm	
Newport® Square	29 lbs	1.04	0.96	3	9	2.88	27				
Newport® Large Rectangle	29 lbs	0.52	1.93	3	9	5.79	27				
								Combined Weight	3020 lbs	All Sizes Together	



Due to variations in printing, color selections should always be chosen from actual product samples. Americana Collection pavers require a buffer between the plate compactor and the paver surface to prevent scuffing.



Driftwood

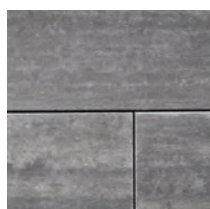

Granite

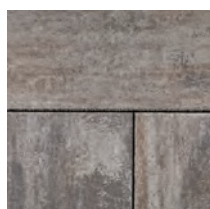

Storm



# Plymouth®



PAVERS

AMERICANA COLLECTION



**Plymouth**  
4" x 8" x 2 3/8"



**Plymouth**  
4" x 8" x 3 1/8"  
(Special Order)



**Plymouth False Joint**  
4" x 8" x 3 1/8"  
(Special Order)

## APPLICATIONS

Pedestrian traffic, residential driveways, patios, borders and swimming pool decks. Vehicular-Rated.

## INSTALLATION PATTERNS

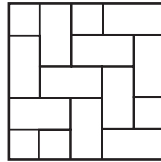

90° Herringbone

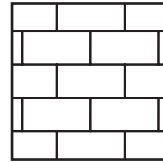

Running Bond

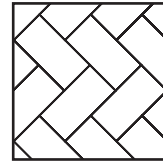

45° Herringbone

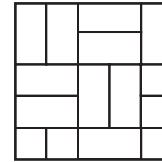

Basket-weave

## PACKAGING INFO

PRODUCT	WEIGHT PER SQ. FT.	UNITS PER SQ. FT.	SQ. FT. PER UNIT	UNITS PER LAYER	LAYERS PER CUBE	SQ. FT. PER LAYER	UNITS PER CUBE	WEIGHT PER CUBE	TOTAL SQ. FT. PER CUBE	COLORS STOCKED
Plymouth®	29 lbs	4.7	0.21	54	9	11.48	486	2999 lbs	103	Charcoal, Cream, Dark Chocolate, Khaki, Silver Mist



Due to variations in printing, color selections should always be chosen from actual product samples. Americana Collection pavers require a buffer between the plate compactor and the paver surface to prevent scuffing.



Charcoal



Cream



Dark Chocolate



Khaki



Silver Mist

# Jamestown®



**Jamestown**  
 $2\frac{5}{8}'' \times 7\frac{7}{8}'' \times 2\frac{3}{8}''$

## INSTALLATION PATTERNS

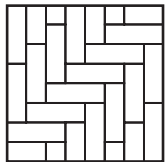

90° Herringbone

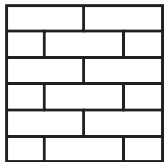

Running Bond

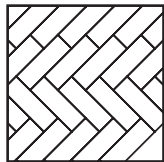

45° Herringbone

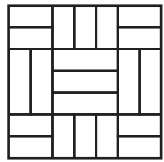

Pattern A

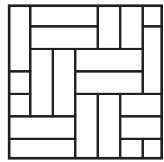

Pattern B

## APPLICATIONS

Perfect for sidewalks, outlying entertaining spaces, or creating decorative inlays.

## PACKAGING INFO

PRODUCT	WEIGHT PER SQ. FT.	UNITS PER SQ. FT.	SQ. FT. PER UNIT	UNITS PER LAYER	LAYERS PER CUBE	SQ. FT. PER LAYER	UNITS PER CUBE	WEIGHT PER CUBE	TOTAL SQ. FT. PER CUBE	COLORS STOCKED
Jamestown®	29 lbs	7.14	0.14	78	5	10.92	390	1583 lbs	54.60	Cream, Charcoal Smooth, Salt & Pepper, Silver Mist



Due to variations in printing, color selections should always be chosen from actual product samples. Americana Collection pavers require a buffer between the plate compactor and the paver surface to prevent scuffing.



Charcoal Smooth



Charcoal Textured  
 (While Supplies Last)



Cream



Salt & Pepper



Silver Mist



Burgundy  
 While Supplies Last

# CityStone™ XL



PAVERS

AMERICANA COLLECTION



**CityStone™ 12x24**  
12" x 24" x 2 3/8"

**CityStone™ 24x24**  
24" x 24" x 2 3/8"

## INSTALLATION PATTERNS

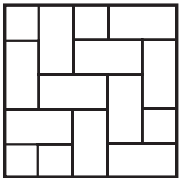

90° Herringbone  
12x24

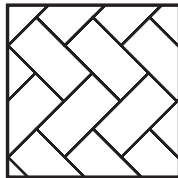

45° Herringbone  
12x24

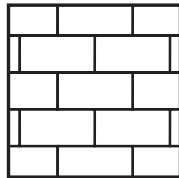

Running Bond  
12x24, 24x24

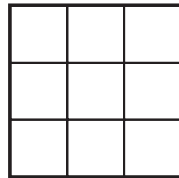

Stack Bond  
24x24

## APPLICATIONS

Perfect for sidewalks, outlying entertaining spaces, or creating courtyards.

## PACKAGING INFO

PRODUCT	WEIGHT PER SQ. FT.	UNITS PER SQ. FT.	SQ. FT. PER UNIT	LAYERS PER CUBE	WEIGHT PER PIECE	UNITS PER CUBE	WEIGHT PER CUBE	TOTAL SQ. FT. PER CUBE	COLORS STOCKED
CityStone™ 12x24	29 lbs	.50	2	10	54.25	60	3255	120	Cream, Driftwood, Silver Mist, Storm
CityStone™ 24x24	29 lbs	.25	4	10	112	20	2240	80	Cream, Driftwood, Silver Mist, Storm



Due to variations in printing, color selections should always be chosen from actual product samples. Americana Collection pavers require a buffer between the plate compactor and the paver surface to prevent scuffing.

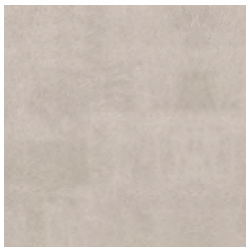

Cream



Driftwood



Silver Mist

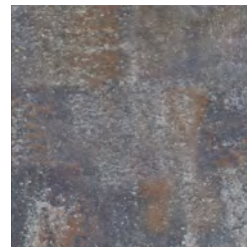

Storm



# Grand Flagstone\*



## Grand Flagstone\*

Dimensions – All Grand Flagstone is 1 3/4" thick

**Note:** Outside dimensions of each layer are identical to all other layers, allowing any layer to be used anywhere in the pattern.

Each pallet contains 2 each of the following layers:

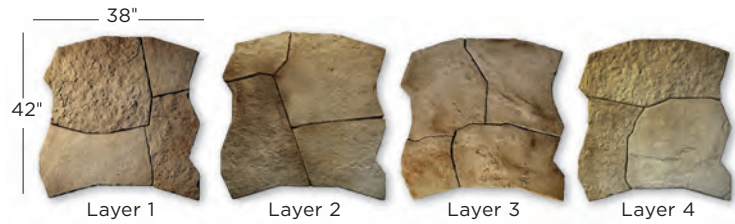

## APPLICATIONS

Pedestrian traffic, patios, borders, swimming pool decks, and sidewalks.

## INSTALLATION PATTERNS

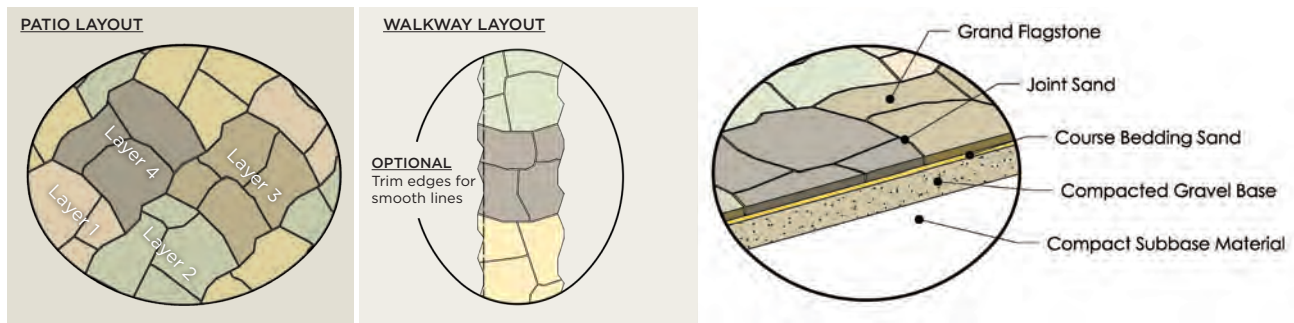

## PACKAGING INFO

PRODUCT	WEIGHT PER SQ. FT.	UNITS PER SQ. FT.	LAYERS PER CUBE	UNITS PER CUBE	WEIGHT PER CUBE	SQ. FT. PER UNIT	SQ. FT. PER LAYER	TOTAL SQ. FT. PER CUBE	COLORS STOCKED
Grand Flagstone	20.5	N/A	8	32	2160	N/A	11	88	Special Order Only



Due to variations in printing, color selections should always be chosen from actual product samples.



\* Not Available in Michigan.



Cuyahoga  
(Special Order Only)



Mohican  
(Special Order Only)

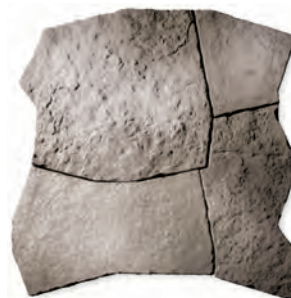

Scioto  
(Special Order Only)

# Dimensional Flagstone\*



- a) Dimensional Flagstone\* - 6" x 12" x 2"
- b) Dimensional Flagstone\* - 12" x 12" x 2"
- c) Dimensional Flagstone\* - 12" x 18" x 2"
- d) Dimensional Flagstone\* - 18" x 18" x 2"
- e) Dimensional Flagstone\* - 18" x 24" x 2"
- f) Dimensional Flagstone\* - 24" x 24" x 2"

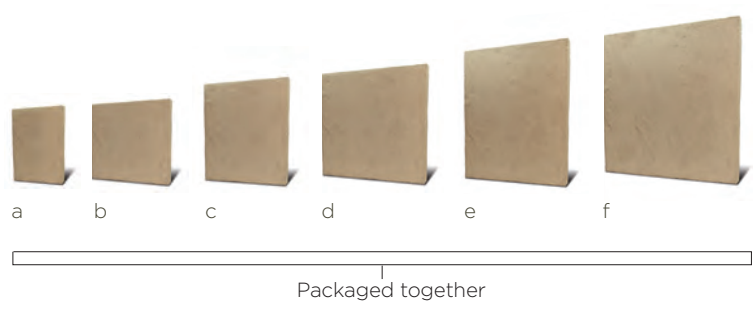

## APPLICATIONS

Pedestrian traffic, patios, swimming pool decks, and sidewalks.

## INSTALLATION PATTERNS

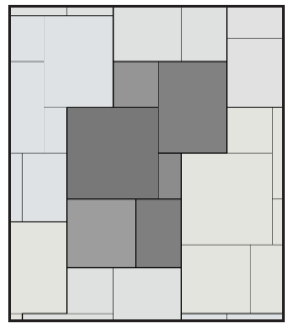

Patio Layout

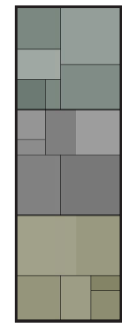

Walkway Layout

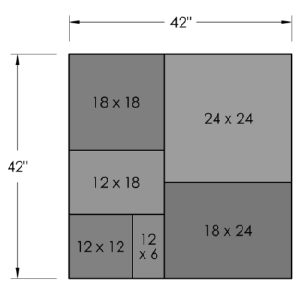
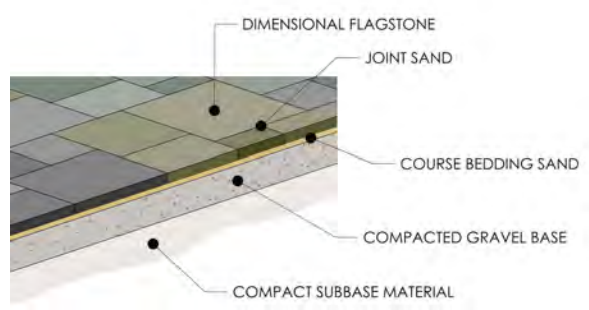

One Layer = 1 Pattern

## PACKAGING INFO

PRODUCT	WEIGHT PER SQ. FT.	UNITS PER SQ. FT.	LAYERS PER CUBE	UNITS PER CUBE	WEIGHT PER CUBE	SQ. FT. PER UNIT	SQ. FT. PER BAND	TOTAL SQ. FT. PER CUBE	COLORS STOCKED
Dimensional Flagstone	24.0	N/A	8	48	2350	N/A	12.25	98	Special Order Only



Due to variations in printing, color selections should always be chosen from actual product samples.



\* Not Available in Michigan.



Cuyahoga  
(Special Order Only)

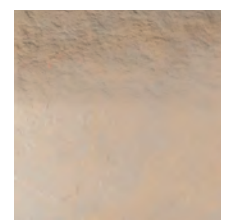

Mohican  
(Special Order Only)



Scioto  
(Special Order Only)



# Special Reserve Travertine & Marble



- a) **Small Rectangle** - 6" x 12" x 1 1/4"
- b) **Small Square\*** - 8" x 8" x 1 1/4"
- c) **Small Rectangle\*** - 8" x 16" x 1 1/4"
- d) **Large Square\*** - 16" x 16" x 1 1/4"
- e) **Large Rectangle\*** - 16" x 24" x 1 1/4"
- f) **Bullnose** - 12" x 24" x 1 1/4", 12" x 24" x 2"

\* French Pattern, Herringbone, Running Bond

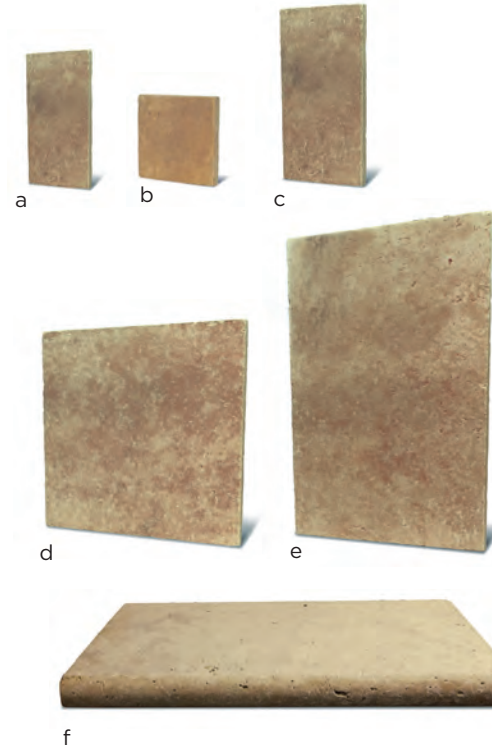

## APPLICATIONS

Pedestrian traffic, patios, swimming pool decks, and sidewalks.

## INSTALLATION PATTERNS

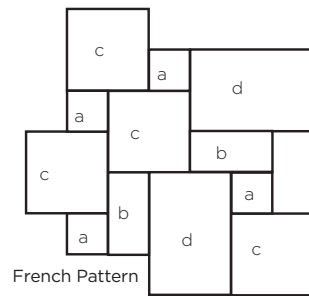

**Each Layer: 8 sq. ft. =**

- 2 pcs: 8" x 8"
- 1 pc: 8" x 16"
- 2 pcs: 16" x 16"
- 1 pc: 16" x 24"

French Pattern

6" 12" units can be installed in a running bond, 45° herringbone or 90° herringbone pattern.

## PACKAGING INFO

PRODUCT	STOCKED	DIMENSIONS	PCS. PER CRATE	SQ. FT. PER CRATE	WEIGHT PER CRATE	COLORS
Special Reserve Marble & Travertine		French Pattern	132	176	2933	Special Order
Special Reserve Marble		6" x 12" x 1 1/4"	400	200	3333	Special Order
Special Reserve Travertine		6" x 12" x 1 1/4"	400	200	3000	Special Order
Special Reserve Bullnose Coping		12" x 24" x 1 1/4"	66	132	990	Special Order
Special Reserve Bullnose Coping		12" x 24" x 2"	40	80	800	Special Order



Due to variations in printing, color selections should always be chosen from actual product samples.

**All Special Reserve Travertine & Marble pavers must be purchased in full cube quantities. Special Order Only**

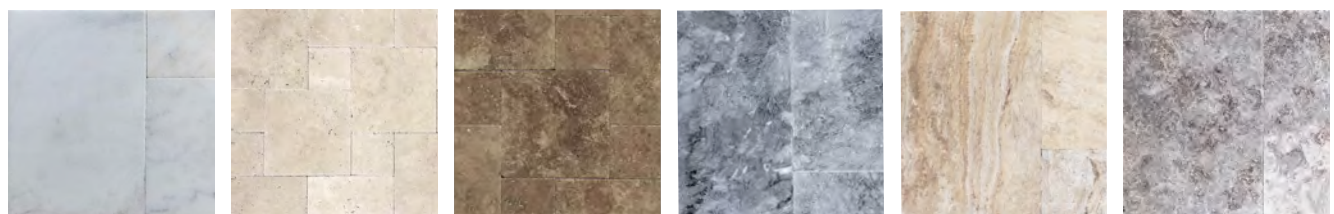

Ice Marble

Ivory Tusk

Noce Trail

Tahoe Marble

Sand Dune

Silver



# Natural Stone



**Natural Stone**  
11.81" x 23.62" x 1"



**Natural Stone**  
17.72" x 23.62" x 1"

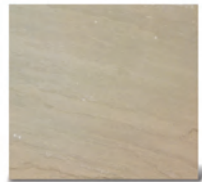

**Natural Stone**  
23.62" x 23.62" x 1"

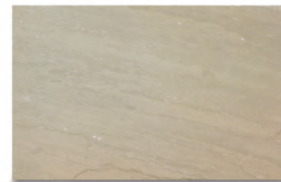

**Natural Stone**  
23.62" x 35.43" x 1"

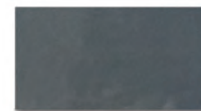

**Natural Stone Limestone**  
11.81" x 23.62" x 1"

## INSTALLATION PATTERN

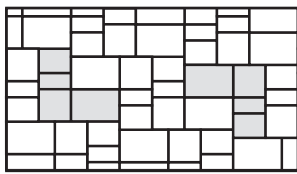

Combo Pack

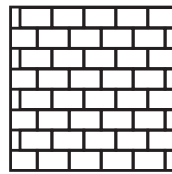

Running Bond  
11.81" x 23.62",  
17.72" x 23.62", or  
23.62" x 35.43"

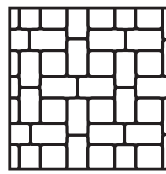

Jumbo Muster K  
28% Large Sq.  
72% Jumbo Rec.

## APPLICATIONS

Pedestrian traffic, patios, swimming pool decks, and sidewalks.

## PACKAGING INFO

PRODUCT	WEIGHT PER SQ. FT.	UNITS PER SQ. FT.	UNITS PER BAND	UNITS PER CUBE	WEIGHT PER CUBE	SQ. FT. PER UNIT	SQ. FT. PER BAND	TOTAL SQ. FT. PER CUBE	COLORS
Natural Stone 11.81" x 23.62"	13.2	N/A	N/A	80	2000	N/A	N/A	160	Special Order
Natural Stone 17.72" x 23.62"	13.2	N/A	N/A	80	2800	N/A	N/A	240	Special Order
Natural Stone 23.62" x 23.62"	13.2	N/A	N/A	40	2000	N/A	N/A	160	Special Order
Natural Stone 23.62" x 35.43"	13.2	N/A	N/A	40	2800	N/A	N/A	240	Special Order
Combo Pack (combination of 4 sizes above)	13.2	N/A	N/A	47	2218	N/A	N/A	168	Special Order
Natural Stone Limestone 11.81" x 23.62"	16.5	N/A	N/A	74	2100	N/A	N/A	148	Special Order



Due to variations in printing, color selections should always be chosen from actual product samples.

**All Special Reserve Travertine & Marble pavers must be purchased in full cube quantities.**

**Special Order Only**

## LIMESTONE COLORS

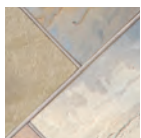

Bronte

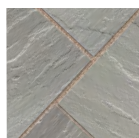

Dove Grey

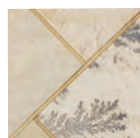

Fossil

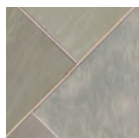

Slate Grey

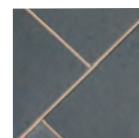

Kota Black

# Eco-Elite™

## L-10



### Eco-Elite™ L-10

9 13/16" x 9 13/16" x 3 1/8"  
250mm x 250mm x 80mm  
(Special Order)

Snow removal equipment should have the proper spacing, bumper and rubber blade guards to protect the surface of the pavers.

### PACKAGING INFO

PRODUCT	PIECES PER PALLET	LAYERS PER PALLET	WEIGHT PER PALLET	SQ. FT. PER PALLET	COLORS STOCKED
Eco-Elite™ L-10	196	7	3374	88	Special Order



Due to variations in printing, color selections should always be chosen from actual product samples.



Granite

Bronte



# Edington Wall Stone®



**Edington Wall Stone®**  
12" x 8" x 4"



**Edington Wall Stone® Wedge**  
12" x 8" x 4"



**Non-Tumbled Edington Wall Stone®**  
12" x 8" x 4"



**Non-Tumbled Edington Wall Stone® Wedge**  
12" x 8" x 4"

## APPLICATIONS

Garden walls, freestanding walls, columns and edging with a 3' height maximum.



### EDINGTON® FIRE PIT KIT

Build a fire pit in no time with our Edington® Fire Pit Kit. This kit has an outside diameter of 48" and a height of 12". Kit includes a steel metal ring. Optional precast caps are available for a different look at an additional cost. Great for small fires, roasting marshmallows and hot dogs.

## PACKAGING INFO

PRODUCT	WEIGHT PER SQ. FT.	UNITS PER SQ. FT.	UNITS PER BAND	UNITS PER CUBE	WEIGHT PER CUBE	SQ. FT. PER UNIT	SQ. FT. PER BAND	TOTAL SQ. FT. PER CUBE	COLORS STOCKED
Edington Wall Stone®	90	3.00	N/A	100	2900	0.333	N/A	33	Canyon Creek, Charcoal, Driftwood, Earth, Flagstone, Granite, Storm, Silver Mist
Edington Wall Stone® Wedge	75	3.00	N/A	90	2160	0.333	N/A	30	Canyon Creek, Charcoal, Driftwood, Earth, Flagstone, Granite, Storm, Silver Mist
Non-Tumbled Edington Wall Stone®	90	3.00	N/A	132	3960	0.333	N/A	33	Canyon Creek, Charcoal, Driftwood, Earth, Flagstone, Granite, Storm, Silver Mist
Non-Tumbled Edington Wall Stone® Wedge	75	3.00	N/A	90	2250	0.333	N/A	30	Canyon Creek, Charcoal, Driftwood, Earth, Flagstone, Granite, Storm, Silver Mist

 Due to variations in printing, color selections should always be chosen from actual product samples.

### Tumbled



Canyon Creek Charcoal Driftwood Earth Flagstone Granite Silver Mist Storm

### Non - Tumbled



Canyon Creek Charcoal Driftwood Earth Flagstone Granite Silver Mist Storm



# Belvedere Wall\*



Wall blocks come in different sizes to create a double sided wall. Belvedere also available in corners and copings.

## APPLICATIONS

Walls or freestanding columns proportionately scaled for residential applications.

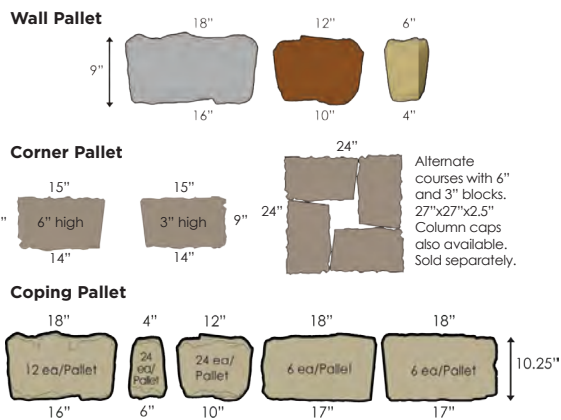

## INSTALLATION PATTERNS

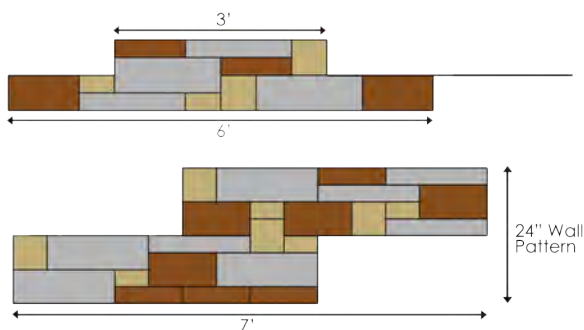

## PACKAGING INFO

PRODUCT	WEIGHT FACE FT.	UNITS FACE FT.	UNITS PER BAND	UNITS PER CUBE	WEIGHT PER CUBE	SQ. FT. PER UNIT	SQ. FT. PER BAND	TOTAL SQ. FT. PER CUBE	COLORS STOCKED
Belvedere Walls	91.667	N/A	N/A	N/A	2475	N/A	N/A	27	Cuyahoga, Mohican, Scioto
Belvedere Corners	63.33	N/A	N/A	N/A	1520	N/A	N/A	24	Cuyahoga, Mohican, Scioto
Belvedere Coping	N/A	N/A	N/A	N/A	1550	N/A	N/A	66/LNFT	Cuyahoga, Mohican, Scioto

## BLOCK DETAILS

STONE & BUNDLING	Unit Dimensions L" x W" x H"	Units/ Cube	Weight/ Stone lbs.
Wall Pallet	Block 1	6" x 9" x 3"	12
	Block 2	12" x 9" x 3"	12
	Block 3	18" x 9" x 3"	12
	Block 4	6" x 9" x 6"	12
	Block 5	12" x 9" x 6"	12
	Block 6	18" x 9" x 6"	12
Corner Pallet	Block 7	15" x 9" x 3"	16
	Block 8	15" x 9" x 6"	16
Coping Pallet	Block 9	6" x 10.25" x 2.25"	24
	Block 10	12" x 10.25" x 2.25"	24
	Block 11	18" x 10.25" x 2.25"	12
	Block 12	18" x 10.25" x 2.25" (Left End)	6
	Block 13	18" x 10.25" x 2.25" (Right End)	6
	Belvedere Column Cap	27" x 27" x 2.25"	10



Due to variations in printing, color selections should always be chosen from actual product samples.



\* Not Available in Michigan.



Cuyahoga



Mohican



Scioto

### Coping Pallet

- Pallet weight = 31,550 lbs (incl. pallet weight)
- Coverage = 66 linear feet per Pallet
- Section = 11 linear feet per 1 layer

Coping blocks are provided in five basic sizes. There are three standard coping blocks which are finished on the front, back, and top faces. The standard coping blocks are tapered approximately 1" on each side from the front to the back of the block. There are also two end units which are finished on front, back, top, and one of the sides. The other side is tapered approximately 1" from the front to the back of the block. The end units are useful for constructing corners and ends. There are multiple face/texture patterns for each basic block size, providing a more random look for your finished project.

Dimensional Coping is also an option for capping the Belvedere Wall. Average block weights of the different face/texture patterns are shown. Weights of individual blocks may vary.

# Dimensional Wall\*



## APPLICATIONS

Garden walls, freestanding walls, columns and edging.



**Dimensional Wall Straight Block\***  
12" x 8" x 4"



**Dimensional Wall Wedge Block\***  
12" x 8" x 4"

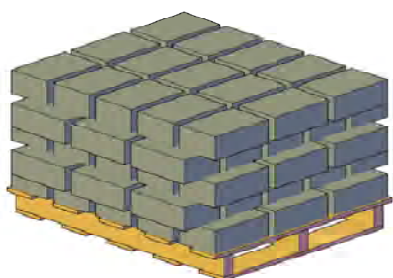

### Dimensional Straight Pallet

- 75 pieces / pallet
- 28# / piece
- 2100# / pallet

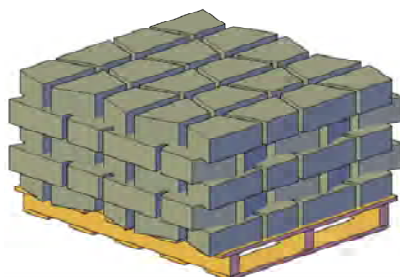

### Dimensional Wedge Pallet

- 100 pieces / pallet
- 20# / piece
- 2000# / pallet

## PACKAGING INFO

PRODUCT	WEIGHT FACE FT.	UNITS PER FACE FT.	UNITS PER BAND	UNITS PER CUBE	WEIGHT PER CUBE	SQ. FT. PER UNIT	SQ. FT. PER BAND	TOTAL SQ. FT. PER CUBE	COLORS STOCKED
Dimensional Wall	84	3.00	N/A	75	2100	.333	N/A	25	Cuyahoga, Mohican, Scioto
Dimensional Wedge	N/A	3.00	N/A	100	2000	.333	N/A	N/A	Cuyahoga, Mohican, Scioto



Due to variations in printing, color selections should always be chosen from actual product samples.



\* Not Available in Michigan.



Cuyahoga

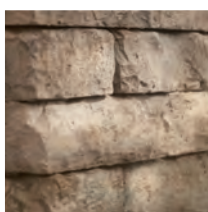

Mohican



Scioto



# Kodah Wall\*



Packaged Together



**Kodah Wall**  
12" x 10.5" x 6"



**Kodah Wall**  
30" x 10.5" x 6"



**Kodah Wall**  
21" x 10.5" x 6"



**Kodah Wall**  
42" x 10.5" x 6"



**Kodah Wall Corner**  
21" x 10.5" x 6"

## APPLICATIONS

Garden walls, gravity walls, freestanding walls, columns and edging.

## INSTALLATION

### Engineered Retaining Wall

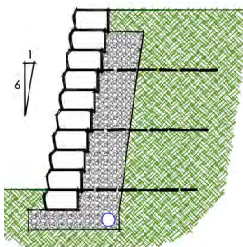

### Freestanding Wall

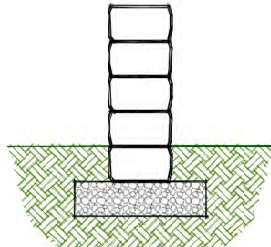

## BLOCK DETAILS

STONE & BUNDLING	Unit Dimensions L" x W" x H"	Units/ Cube	Weight/ Stone lbs.	
Freestanding Wall Pallet	Block 1	42" x 10.5" x 6"	6	2003
	Block 2	30" x 10.5" x 6"	3	1403
	Block 3	21" x 10.5" x 6"	6	1003
	Block 4	12" x 10.5" x 6"	3	503
Corner Pallet	Block 5	21" x 10.5" x 6"	16	1003

Kodah Freestanding Wall Blocks are provided in four basic sizes. The blocks are finished on both the front and back faces of the wall blocks and they are tapered on each side approximately 1 1/2" from the front to the back of the block. There are multiple texture patterns for each basic block size to provide a more random look for your finished project. Average block weights of the different texture patterns are shown. Weights of individual blocks may vary.

The Kodah Collection contains two corner blocks. These blocks are finished on three sides, and the fourth side is tapered to fit with the other retaining wall and freestanding wall blocks. The corner blocks can be used to construct columns, provide a finished end on a freestanding wall, and make 90° corners. There are multiple texture patterns for the faces of both corner blocks, thus providing a more random look for your finished project. Average block weights of the different texture patterns are shown. Weights of individual blocks may vary.

## PACKAGING INFO

PRODUCT	WEIGHT FACE FT.	UNITS FACE FT.	UNITS PER BAND	UNITS PER CUBE	WEIGHT PER CUBE	SQ. FT. PER UNIT	SQ. FT. PER BAND	TOTAL SQ. FT. PER CUBE	COLORS STOCKED
Kodah Wall Pallet	N/A	N/A	N/A	18	2370	N/A	N/A	21	Cuyahoga, Mohican, Scioto
Kodah Corner Pallet	N/A	N/A	N/A	16	1600	1.3	N/A	21	Cuyahoga, Mohican, Scioto



Cuyahoga



Mohican



Scioto





# Outcropping Wall\*



**a) Outcropping Wall Stone -**

Recommended Ratio

2 A Pallets

2 B Pallets

1 C Pallet

**b) Outcropping Wall Stone\* Corner 6"**

**c) Outcropping Wall Stone\* Corner 12"**

## APPLICATIONS

Residential or commercial engineered wall system.

## PATTERNS

Pre-drawn patterns and custom layout software saves time in estimating and installation.

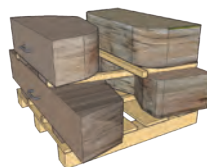
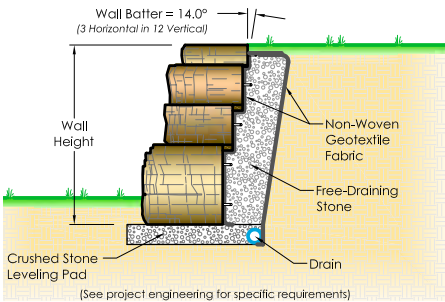
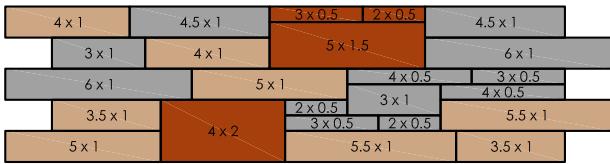

Sample Pallet

**Pallet A: 18 s.f., 4,000 lbs**



42" L x 18" D x 12" H  
750 lbs.



48" L x 18" D x 12" H  
900 lbs.



60" L x 18" D x 12" H  
1100 lbs.



66" L x 18" D x 12" H  
1150 lbs.

**Pallet B: 18 s.f., 4,000 lbs**



24" L x 18" D x 6" H  
250 lbs.

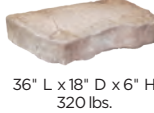

36" L x 18" D x 6" H  
320 lbs.

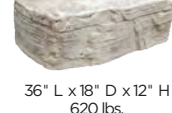

36" L x 18" D x 12" H  
620 lbs.



48" L x 18" D x 6" H  
450 lbs.



54" L x 18" D x 12" H  
950 lbs.



72" L x 18" D x 12" H  
1300 lbs.

**Pallet C: 18 s.f., 4,000 lbs**



24" L x 18" D x 6" H  
250 lbs.



36" L x 18" D x 6" H  
320 lbs.



48" L x 18" D x 24" H  
1800 lbs.



60" L x 18" D x 18" H  
1600 lbs.

**Corner Pallet 6": 4 units, 1920 lbs**

**Corner Pallet 12": 2 units, 2340 lbs**



39" L x 27" W x 6" H  
480 lbs.



48" L x 30" W x 12" H  
1170 lbs.

## PACKAGING INFO

PRODUCT	WEIGHT FACE FT.	UNITS FACE FT.	UNITS PER BAND	UNITS PER CUBE	WEIGHT PER CUBE	SQ. FT. PER UNIT	SQ. FT. PER BAND	TOTAL SQ. FT. PER CUBE	COLORS STOCKED
Outcropping	222.22	N/A	N/A	N/A	4000	N/A	N/A	18	Cuyahoga, Mohican, Scioto



Cuyahoga



Mohican



Scioto



Due to variations in printing, color selections should always be chosen from actual product samples.



\* Not Available in Michigan.

# Versa-Lok®



**Versa-Lok®**  
16" (face) x 14" (rear) x 12" D x 6" H



**Smooth Top Versa-Lok®**  
16" (face) x 14" (rear) x 12" D x 6" H



**Rectangular Cap**  
16" (face) x 11<sup>5</sup>/<sub>8</sub>" D x 3<sup>5</sup>/<sub>8</sub>" H



**Solid Corner**  
7<sup>7</sup>/<sub>8</sub>" (face) x 12" D x 6" H



**Full Return Corner**  
16" (face) x 7<sup>7</sup>/<sub>8</sub>" D x 6" H



**Charcoal**  
Rectangular Cap Only

## APPLICATIONS

Residential or commercial engineered retaining wall applications.

**Weathered Versa-Lok available Special Order Only.**

## PACKAGING INFO

PRODUCT	WEIGHT FACE FT.	UNITS FACE FT.	UNITS PER BAND	UNITS PER CUBE	WEIGHT PER CUBE	SQ. FT. PER UNIT	SQ. FT. PER BAND	TOTAL SQ. FT. PER CUBE	COLORS STOCKED
Non-Weathered Versa-Lok® Standard	123	1.50	N/A	32	2624	0.667	N/A	21.33	Canyon Creek, Chestnut, Desert Sand, Earth, Flagstone, Granite, Storm
Non-Weathered Versa-Lok® Smooth Top Standard	123	1.50	N/A	32	2624	0.667	N/A	21.33	Canyon Creek, Chestnut, Desert Sand, Earth, Flagstone, Granite, Storm
Non-Weathered Rectangular Retaining Wall Cap	51	N/A	N/A	48	2448	N/A	N/A	N/A	Canyon Creek, Charcoal, Chestnut, Desert Sand, Earth, Flagstone, Granite, Storm
Non-Weathered Versa-Lok® Solid Corner	41	3.00	N/A	64	2624	N/A	N/A	N/A	Canyon Creek, Chestnut, Desert Sand, Earth, Flagstone, Granite, Storm
Non-Weathered Versa-Lok® Full Return Corner	48	N/A	N/A	48	2304	N/A	N/A	N/A	Canyon Creek, Chestnut, Desert Sand, Earth, Flagstone, Granite, Storm



Due to variations in printing, color selections should always be chosen from actual product samples.

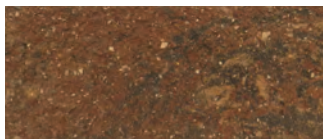

Canyon Creek



Chestnut



Desert Sand



Earth

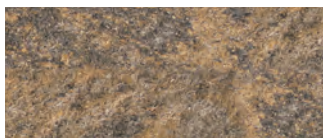

Flagstone

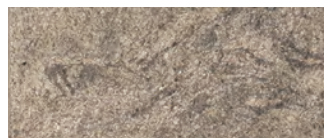

Granite



Storm



# RegalStone Pro<sup>®</sup> Straight Face



WALLS



**RegalStone Pro<sup>®</sup>**  
18" (face) x 12" D x 8" H



**Reversible Corner**  
18" (face) x 8" D x 8" H



**Rectangular Cap**  
18" (face) x 12" D x 4" H

## APPLICATIONS

Residential or commercial engineered retaining wall applications.

## PACKAGING INFO

PRODUCT	WEIGHT FACE FT.	UNITS FACE FT.	UNITS PER BAND	UNITS PER CUBE	WEIGHT PER CUBE	SQ. FT. PER UNIT	SQ. FT. PER BAND	TOTAL SQ. FT. PER CUBE	COLORS
Regal Stone Pro <sup>®</sup> Straight	76 lbs	1	8	40	3040	1	8	320	Earth, Flagstone, Storm
Reversible Corner	65 lbs	N/A	N/A	40	2600	N/A	N/A	40	Earth, Flagstone, Storm
Rectangular Cap	67 lbs	N/A	N/A	48	3216	N/A	N/A	24	Earth, Flagstone, Storm



Due to variations in printing, color selections should always be chosen from actual product samples.



Earth

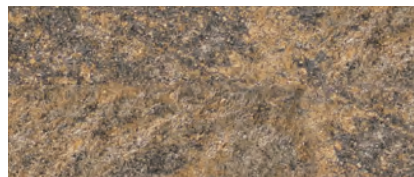

Flagstone



Storm



CUSTOM COLORS AVAILABLE



# MagnumStone®



**Standard Block**  
48" (face) x 39" (rear) x  
24"D x 24"H



**Base Block**  
48" (face) x 39" (rear) x 24"D  
x 24"H



**Top Block**  
48" (face) x 39" (rear) x 24"D  
x 24"H

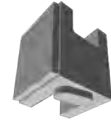

**Standard Block Half**  
24" (face) x 39" (rear) x 24"D  
x 24"H



**Standard Block Half High**  
48" (face) x 39" (rear) x  
24"D 12" H



**Base Block Half High**  
48" (face) x 39" (rear) x  
24"D 12"H



**Top Block Half High**  
48" (face) x 39" (rear) x  
24"D 12"H



**2 ft. Extender**  
30" (rear) x 24"D x 24"H



**4 ft. Extender**  
30" (rear) x 48"D x 24"H



**Corner/End**  
2" (top width) x 4" (bottom  
width) x 8" D x 24"H



**Half High Corner End**  
3" (top width) x 4" (bottom  
width) x 9"D x 12"H

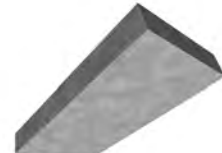

**Cap/Step**  
48"W x 24"D x 6"H

**Special Order Only**

**PACKAGING INFO**

PRODUCT	UNITS PER CUBE	WEIGHT PER UNIT	WEIGHT PER CUBE	COLORS STOCKED
Standard Block	2	1345	2690	Special Order
Base Block	2	1325	2650	Special Order
Top Block	2	1220	2440	Special Order
Standard Block Half	2	1370	2740	Special Order
Standard Block Half High	2	750	1500	Special Order
Base Block Half High	2	725	1450	Special Order
Top Block Half High	2	687	1374	Special Order
2 ft. Extender	2	575	1150	Special Order
4 ft. Extender	2	875	1750	Special Order
Corner/End	2	340	680	Special Order
Half High Corner End	4	170	680	Special Order
Cap/Step	6	560	3360	Special Order



Gray

# Bullnose



STAIR TREADS | WALL COPINGS



**Single Bullnose**  
6" x 12" x 2 3/8"



**Double Bullnose**  
6" x 12" x 2 3/4"

## APPLICATIONS

Steps, wall caps and coping applications.

## PACKAGING INFO

PRODUCT	WEIGHT PER SQ. FT.	UNITS PER SQ. FT.	UNITS PER LAYER	UNITS PER CUBE	WEIGHT PER CUBE	SQ. FT. PER UNIT	TOTAL SQ. FT. PER CUBE	COLORS STOCKED
Single Bullnose Paver	28.0	2.00	N/A	168	2352	N/A	84	Charcoal, Cream, Dark Chocolate, Khaki, Silver Mist
Vintage Single Bullnose Paver	28.0	2.00	N/A	192	2668	N/A	96	Special Order
Double Bullnose Paver	30.0	2.00	N/A	144	2160	N/A	72	Charcoal, Cream, Dark Chocolate, Khaki, Silver Mist
Vintage Double Bullnose Paver	30.0	2.00	N/A	192	2880	N/A	96	Special Order



Due to variations in printing, color selections should always be chosen from actual product samples.



Charcoal



Cream



Dark Chocolate



Khaki



Silver Mist

# Olentangy Bluff Tread™



**Olentangy Bluff Tread™**  
36" L x 16" D x 6" H



**Olentangy Bluff Tread™**  
48" L x 16" D x 6" H



**Olentangy Bluff Tread™**  
60" L x 16" D x 6" H



**Olentangy Bluff Tread™**  
72" L x 16" D x 6" H

## APPLICATIONS

Residential or commercial step applications.

## PACKAGING INFO

PRODUCT	WEIGHT PER SQ. FT.	UNITS PER SQ. FT.	UNITS PER BAND	UNITS PER CUBE	WEIGHT PER CUBE	SQ. FT. PER UNIT	SQ. FT. PER BAND	TOTAL SQ. FT. PER CUBE	COLORS STOCKED
Olentangy Bluff Tread 36"	N/A	N/A	N/A	8	2240	N/A	N/A	N/A	Cuyahoga, Mohican, Scioto
Olentangy Bluff Tread 48"	N/A	N/A	N/A	8	2984	N/A	N/A	N/A	Cuyahoga, Mohican, Scioto
Olentangy Bluff Tread 60"	N/A	N/A	N/A	6	2802	N/A	N/A	N/A	Cuyahoga, Mohican, Scioto
Olentangy Bluff Tread 72"	N/A	N/A	N/A	4	2240	N/A	N/A	N/A	Cuyahoga, Mohican, Scioto



Due to variations in printing, color selections should always be chosen from actual product samples.



Cuyahoga



Mohican



Scioto



# Dimensional & Irregular Steps\*



## A Irregular Steps\*

All irregular steps have 7" rise

42" L x 17" D x 7" H (349 lbs.)

42" L x 26" D x 7" H (476 lbs.)

54" L x 22" D x 7" H (458 lbs.)

48" L x 24" D x 7" H (512 lbs.)

48" L x 28" D x 7" H (567 lbs.)

60" L x 24" D x 7" H (600 lbs.)

Packaged Together

Sold as Full Pallet Only

## B Dimensional Steps\*

All dimensional steps have 7" rise

36" L x 18" D x 7" H (375 lbs.)

48" L x 18" D x 7" H (455 lbs.)

72" L x 30" D x 7" H (1320 lbs.)

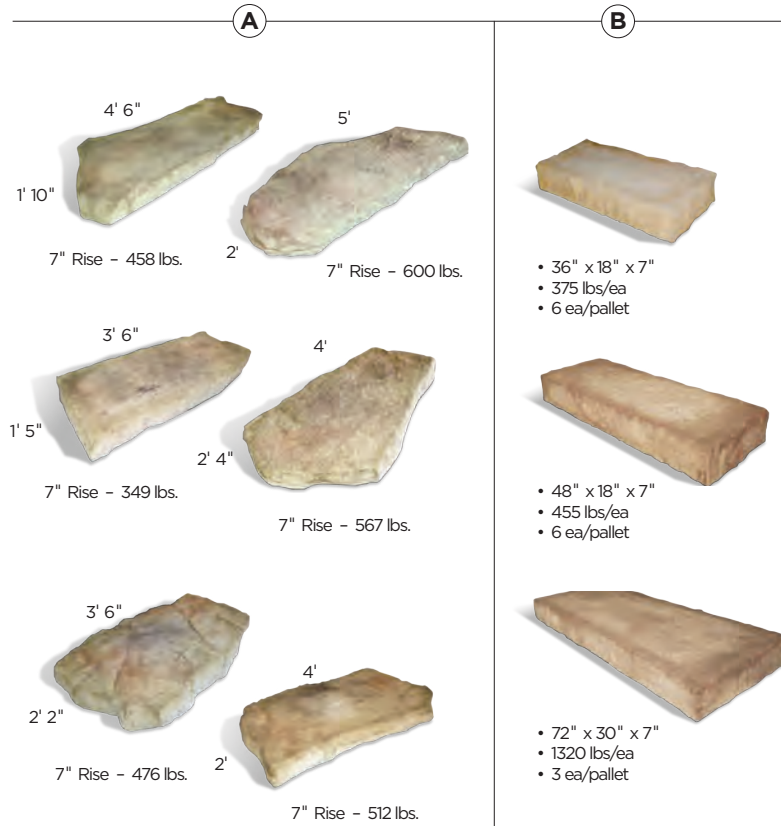

## APPLICATIONS

Residential or commercial step applications.

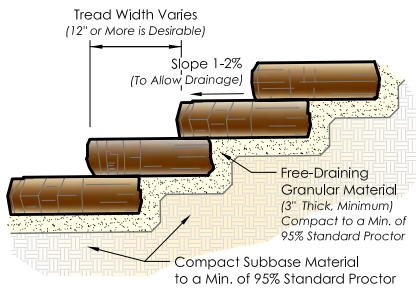

## PACKAGING INFO

PRODUCT	WEIGHT PER SQ. FT.	UNITS PER SQ. FT.	UNITS PER BAND	UNITS PER CUBE	WEIGHT PER CUBE	SQ. FT. PER UNIT	SQ. FT. PER BAND	TOTAL SQ. FT. PER CUBE	COLORS STOCKED
Irregular Steps*	N/A	N/A	N/A	6	2962	N/A	N/A	N/A	Cuyahoga, Mohican, Scioto
Dimensional Steps 3'	N/A	N/A	N/A	6	2250	N/A	N/A	N/A	Cuyahoga, Mohican, Scioto
Dimensional Steps 4'	N/A	N/A	N/A	6	2730	N/A	N/A	N/A	Cuyahoga, Mohican, Scioto
Dimensional Steps 6'	N/A	N/A	N/A	3	3960	N/A	N/A	N/A	Cuyahoga, Mohican, Scioto



Due to variations in printing, color selections should always be chosen from actual product samples.



\* Not Available in Michigan.



Cuyahoga



Mohican



Scioto

# Superior Steppers\*



**Superior Stepper** - 21" x 27" x 2"  
Eight different shapes on a cube.

## PACKAGING INFO

PRODUCT	WEIGHT PER SQ. FT.	UNITS PER SQ. FT.	UNITS PER BAND	UNITS PER CUBE	WEIGHT PER CUBE	SQ. FT. PER UNIT	SQ. FT. PER BAND	TOTAL SQ. FT. PER CUBE	COLORS STOCKED
Superior Steppers	N/A	N/A	N/A	24	1950	N/A	N/A	N/A	Cuyahoga, Mohican, Scioto



Due to variations in printing, color selections should always be chosen from actual product samples.



\* Not Available in Michigan.

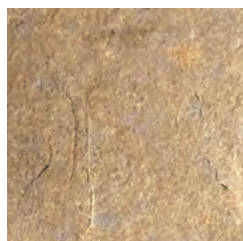

Cuyahoga



Mohican



Scioto



# Dimensional Coping\*



**Standard Coping\***  
18" x 12.5" x 2.5"

Packaged Together



**Finished End Coping\***  
19" x 12.5" x 2.5"



**Long Coping\***  
24" x 12.5" x 2.5"

## APPLICATIONS

Wall applications, stair treads

## BLOCK DETAILS

STONE & BUNDLING

Unit Dimensions L" x W" x H"

Units Bundle Weight/Stone lbs.

Dimensional Coping Pallet	Standard	18" x 12.5" x 2.5"	12	463
	Finished End	19" x 12.5" x 2.5"	6	483
	Long	24" x 12.5" x 2.5"	18	613

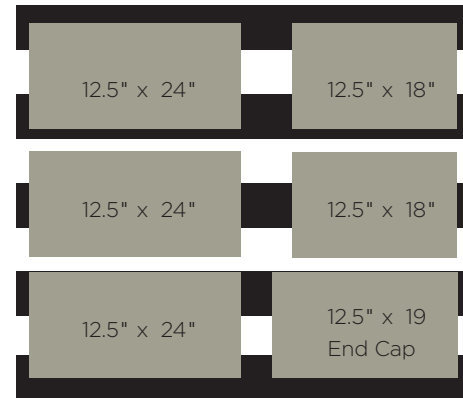

### Dimensional Coping Pallet Overview

- 6 layers per pallet
- 63 LF/pallet
- Section = 10.5 LF per 1 layer.

## PACKAGING INFO

PRODUCT	WEIGHT PER SQ. FT.	UNITS PER SQ. FT.	UNITS PER BAND	UNITS PER CUBE	WEIGHT PER CUBE	SG. FT. PER UNIT	SG. FT. PER BAND	TOTAL SQ. FT. PER CUBE	COLORS STOCKED
Dimensional Coping	N/A	N/A	N/A	N/A	1950	N/A	N/A	63/LNFT	Cuyahoga, Mohican, Scioto



Due to variations in printing, color selections should always be chosen from actual product samples.



\* Not Available in Michigan.



Cuyahoga



Mohican



Scioto



# Edington® Fire Pit Kit



## OVERALL DIMENSIONS

12" H x 48" Diameter  
Weight - 1083 lbs (2 pallets)

Build a fire pit in no time with our Edington Fire Pit Kit. Place base units on 4-6" of prepared compacted base and adhere units as you construct. Great for small fires, roasting marshmallows and hot dogs.

## KIT COMPONENTS

- 39 Edington Wall Stone Wedge Units
- 3 - 10 oz. Tubes of Paver Bond
- Steel Ring
- Optional Grill Grate
- Optional Precast Rockface Caps

**All Items Sold Separately**



Optional  
Precast  
Caps



Canyon Creek



Charcoal



Driftwood



Earth



Flagstone



Granite



Silver Mist



Storm

## PRECAST ROCKFACE CAP COLORS



Cuyahoga



Mohican



Scioto



Due to variations in printing, color selections should always be chosen from actual product samples.

# Belvedere® Fire Pit Kit\*



## OVERALL DIMENSIONS

14" H x 58" Diameter  
Weight - 1348 lbs (1 pallet)

## KIT COMPONENTS

- 52 Belvedere Units
- 3-10 oz. Tubes of Adhesive
- Steel Ring
- Optional Grill Grate

**All Items Sold Separately**

The Belvedere Fire Pit creates a rustic sophistication all its own. The Belvedere Fire Pit has a diameter of approximately five feet and a height of fourteen inches, the proportions of the fire pit creates a perfect focal point for any occasion—from intimate gathers to larger events. The Belvedere Fire Pit blends seamlessly with the entire collection of attractive Rosetta® paver and wall lines. Kit includes steel metal ring.

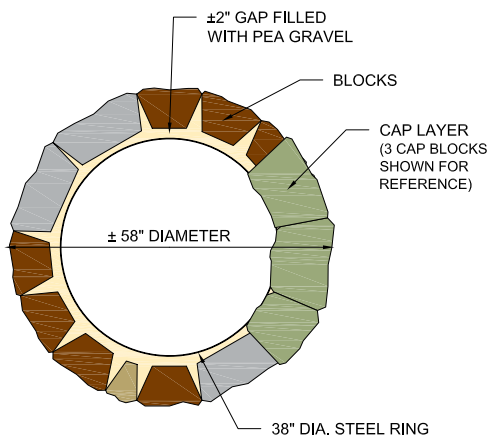

TOP VIEW

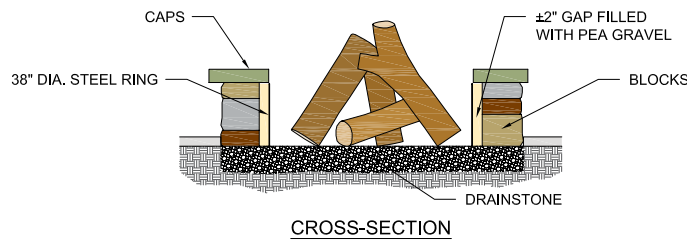

CROSS-SECTION

## SAMPLE BLOCK LAYOUT PATTERN (OPTIONAL)

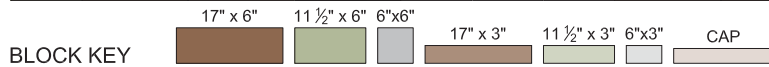
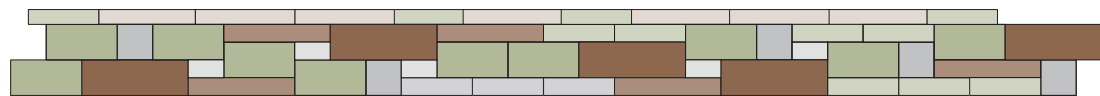

Cuyahoga

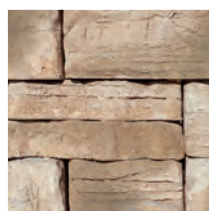

Mohican



Scioto



Due to variations in printing, color selections should always be chosen from actual product samples.



\* Not Available in Michigan.

# Dimensional Fire Pit Kit\*



## OVERALL DIMENSIONS

12" H x 44"W x 44"D  
Weight - 1136 lbs. (1 pallet)

## KIT COMPONENTS

- 36 Dimensional Units
- 3-10 oz. Tubes of Adhesive
- Steel Liner
- Square Fire Pit Pallet: 1,130 lbs

### All Items Sold Separately

The Dimensional Wall Fire Pit Kit features hand-hewn stone texture with consistent dimensions to create a natural looking square fire pit.

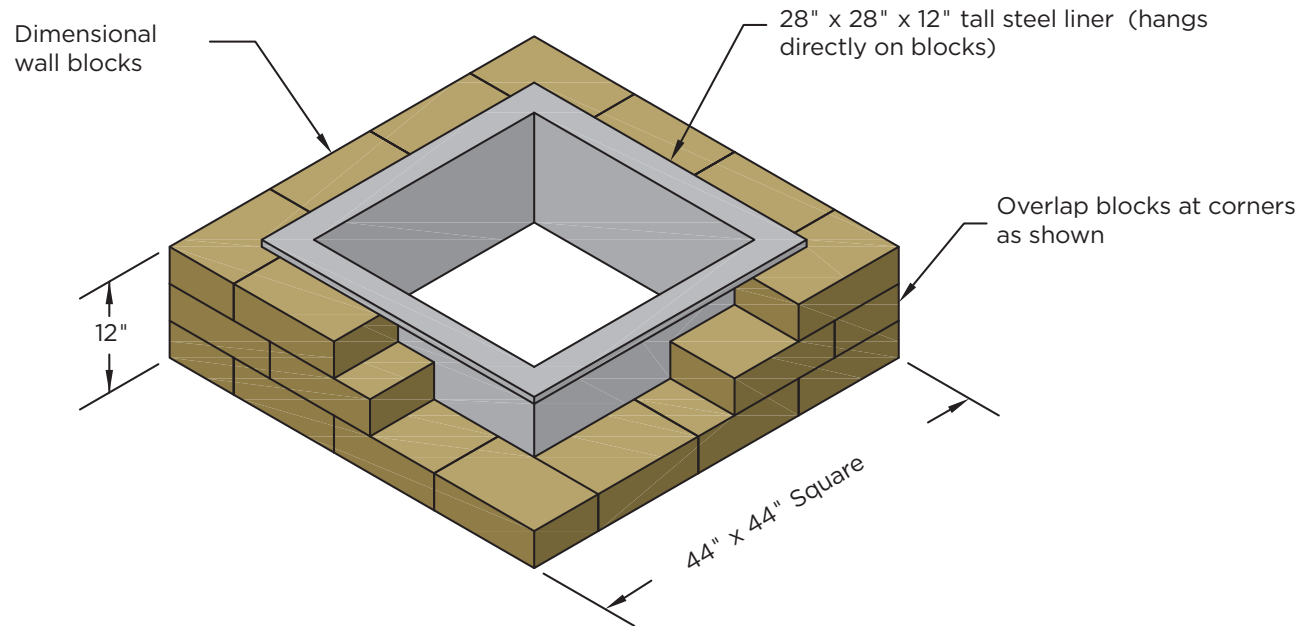

Cuyahoga



Mohican



Scioto



Due to variations in printing, color selections should always be chosen from actual product samples.



\* Not Available  
in Michigan.



# Kodah Fire Pit Kit\*



## OVERALL DIMENSIONS

12" H x 44"W x 48"D  
Weight - 1682 lbs. (1 pallet)

## KIT COMPONENTS

- 16 Kodah Corner Units
- 3-10 oz. Tubes of Adhesive
- Steel Liner

**All Items Sold Separately**

The Kodah fire pit features modern, linear proportions. The freshly quarried stone texture complements a variety of applications. It is designed for fast installation with large blocks and perfectly planned construction.

## TYPICAL COURSE PLAN VIEW

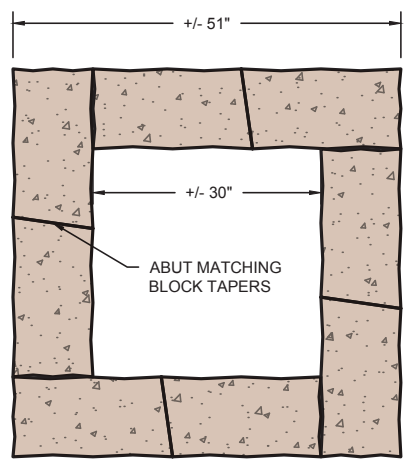

## TYPICAL CONSTRUCTION ISOMETRIC VIEW

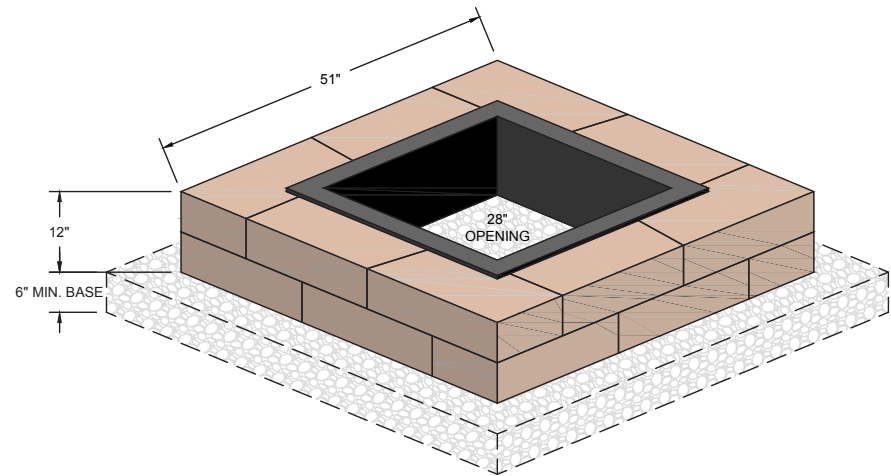

Cuyahoga



Mohican



Scioto



Due to variations in printing, color selections should always be chosen from actual product samples.



\* Not Available in Michigan.

# Edington® Pub Table Kit



## OVERALL DIMENSIONS

42" H x 48"W x 48"D  
Weight - 1752 lbs (2 pallet)

## KIT COMPONENTS

- 36 Edington Wall Stone pieces
- 1-42" Table Top with 2" hole
- 1-28" Foot Rest with 2" hole
  - Both pieces 3" thick
  - The 2" hole fits standard umbrella (not incl.)
- 2-10 oz. Tubes of Adhesive
- Optional 42" Round Table Top with 2" hole (non stock)

### All Items Sold Separately

Available in Tumbled  
& Non-Tumbled



Add additional entertaining space with our Pub Table Kit. The large table top allows plenty of room to enjoy drinks or a snack. The bottom foot rest is great for propping up your feet.



Canyon Creek



Charcoal



Driftwood



Earth



Flagstone



Granite



Silver Mist



Storm

## PRECAST ROCKFACE CAP COLORS



Cuyahoga



Mohican



Scioto



LEXINGTON

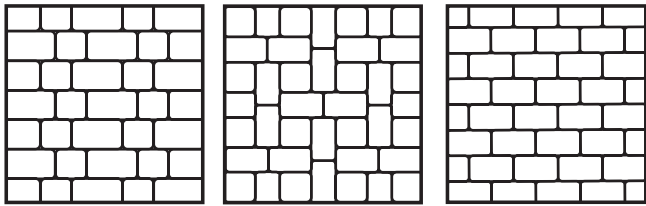

Muster D  
40% Lexington 14  
60% Lexington 21

Muster K  
28% Lexington 14  
72% Lexington 21

Running Bond  
10, 14, or 21

TRAVERTINE PAVERS

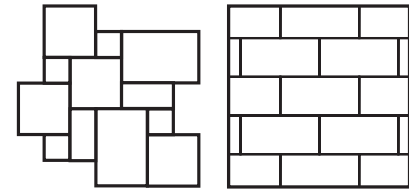

French Pattern

Running Bond

CITYSTONE XL

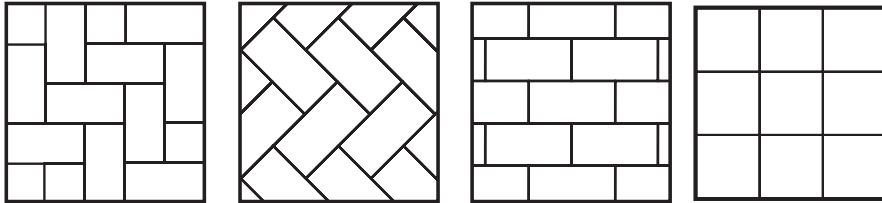

90° Herringbone  
12x24

45° Herringbone  
12x24

Running Bond  
12x24, 24x24

Stack Bond  
24x24

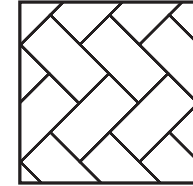

45° Herringbone

PLYMOUTH

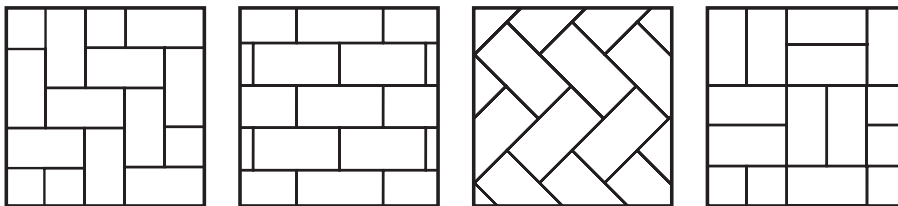

90° Herringbone

Running Bond

45° Herringbone

Basket-weave

JAMESTOWN

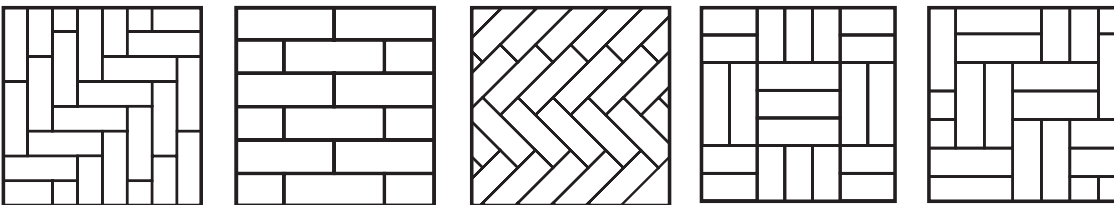

90° Herringbone

Running Bond

45° Herringbone

Pattern A

Pattern B

MALIBU

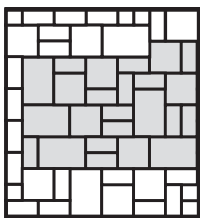

Pattern A

OZARK & MANHATTAN

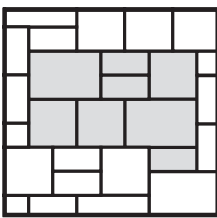

Pattern A

NEWPORT

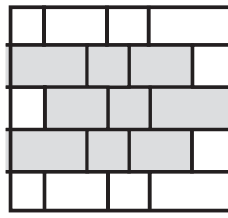

Random  
Running Bond

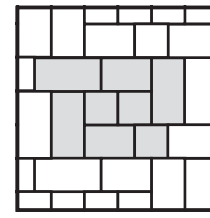

Pattern B

NATURAL STONE PAVERS

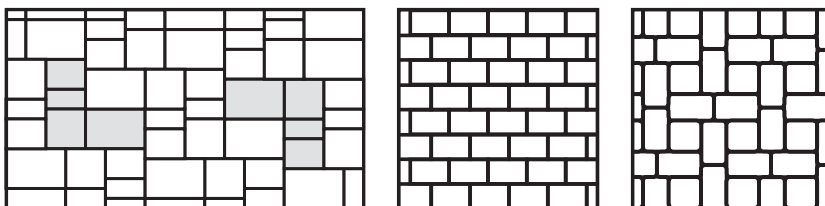

Combo Pack

Running Bond  
11.81" x 23.62",  
17.72" x 23.62", or  
23.62" x 35.43"

Jumbo Muster K  
28% Large Sq.  
72% Jumbo Rec.

\* All random lays are not a pattern. Random lays can consist of any grouping of the pavers. See Oberfields.com for larger format printouts.















## Product Warranty

LIMITED WARRANTY for the Contract Professional, Developer, or other Commercial Purchaser Oberfields, having its headquarters located at Five Concourse Parkway, Atlanta, GA 30328, warrants its products at the time of delivery will meet or exceed the applicable ASTM standards on compressive strength and absorption if installed in accordance with applicable ICPI ([www.icpi.org](http://www.icpi.org)) or NCMA ([www.ncma.org](http://www.ncma.org)) standards. This warranty does not cover standard manufacturing variations, color variations/matching or efflorescence. Oberfields is not responsible for installation of the product or defective conditions caused by installation, abuse, impact, abrasion or alteration of the product, earth-shifts, excessive or unforeseen site conditions, acts of God or application of de-icing salt or other chemicals to the product. Liability under this warranty, if the product is found to be defective, is limited to the replacement of the defective product, or at Oberfields option, the refund of the purchase price of the defective product. Oberfields does not guarantee that the shape or color will be available in the future and will provide an alternate shape or color from its current product line as determined by Oberfields at the time of an accepted warranty claim. This warranty is valid for the lifetime of the product. This warranty is transferable. In the event of a claim under this warranty, notice must be given to Oberfields, together with original proof of purchase, at its headquarters by sending a letter to: Oberfields a/s Warranties, Five Concourse Parkway, Atlanta, GA 30328. THIS WARRANTY IS ISSUED AND ACCEPTED IN LIEU OF ANY AND ALL OTHER EXPRESS OR IMPLIED WARRANTIES OF ANY KIND OR NATURE AND EXPRESSLY EXCLUDES LIABILITY FOR LABOR, FREIGHT AND OTHER COSTS ASSOCIATED WITH REMOVAL AND REPLACEMENT OF THE DEFECTIVE PRODUCT AND FOR INDIRECT AND CONSEQUENTIAL DAMAGES

Due to variations in the printing and photographic processes, actual appearance and color of our products may differ from the appearance reflected in this website or in any of our brochures or other product literature and appearance and color may differ from one brochure or other product literature to the next. Please be advised that this warranty does not cover those appearance and color variations.

Once installed, our products are deemed accepted in terms of surface texture, shape, size, split face geometry, color, color blending and all other aesthetic features

SALES | CORPORATE OFFICE

---

Hardscape & Precast  
528 London Road  
Delaware, Ohio 43015  
614-252-0955  
740-369-7644  
800-845-7644  
Fax 740-363-7644

SALES & MANUFACTURING

---

Hardscape  
4033 Alum Creek Drive  
Obetz, Ohio 43207  
614-252-0955



[oberfields.com](http://oberfields.com)